

APPENDIX E – NAVIGATION SAFETY ASSESSMENT

Relevant details from the Navigation Safety Assessment (NSA) are included in the Malfunctions and Accidents (Section 9.0) and Marine Use (Section 7.11) sections of the Application.

The NSA is part of the Application and is based on guidance from Transport Canada. An NSA is an opportunity for agencies to review the Project and determine whether additional resources (e.g., pilots), controls or infrastructure (e.g., navigational aids) are required and when they need to be in place. The NSA studies and their descriptions are outlined below. The assessment of Malfunctions and Accidents must consider the results of the NSA. Table E.1 provides an overview of the studies and resulting reports that are included in the NSA.

Table E.1 Navigation Safety Assessment Studies

Study	Description
Marine Traffic (Attachment E.1)	<p>The Marine Traffic report describes vessels operating in the region, particularly those likely to be encountered by LNG carriers and NGL product vessels transiting to and from the marine terminal.</p> <p>The report describes and quantifies the regional marine traffic network, including seasonal variations. Network focal points are identified where crossing traffic and close-quarters interactions are more likely.</p> <p>To describe and quantify regional traffic, Automatic Identification System (AIS) data from 2019 and 2021 (i.e., pre and post-COVID) is analysed. The AIS data shows the routes used by different types of commercial vessels. Vessel counts are provided at focal points.</p> <p>The report also estimates traffic that does not carry AIS.</p>
Marine Route (Attachment E.2)	<p>The Marine Route report assesses the suitability of alternate marine routes. The selected marine route is the same marine route used by piloted vessels transiting between open ocean and terminals near Stewart, BC at the head of Portland Canal.</p> <p>Design LNG carriers and NGL product vessels arriving from the Pacific Ocean, will travel north of Haida Gwaii through Dixon Entrance to the Triple Island pilot boarding station. From the Triple Island pilot boarding station, vessels will travel south of the Dundas Island Group and north through Chatham Sound to Portland Inlet. Vessels will then proceed to Portland Canal and the marine terminal at the northern end of Pearse Island.</p> <p>The objectives of the report are to:</p> <ul style="list-style-type: none"> ▪ Assess the navigability of LNG carriers and NGL product vessels along the marine route and identify areas where navigation requires particular attention ▪ Identify meteorological and ocean conditions along the marine route that could affect safe navigation ▪ Assess the suitability of existing anchorages and holding areas for LNG carriers and NGL product vessels ▪ Identify the need for improvements to existing aids to navigation or vessel traffic services

Study	Description
<p>Marine Route (Attachment E.2) (cont'd)</p>	<p>A desktop navigation simulation report is appended to the Marine Route report. The objectives of the desktop simulation are to:</p> <ul style="list-style-type: none"> ▪ Assess the marine route for the design vessels over a range of conditions, to draw conclusions about the overall navigational safety of the marine route and limiting operational conditions ▪ Determine the factors and variables having the strongest influence on vessel manoeuvrability ▪ Make recommendations for the Navigational Risk Assessment (NRA) with respect to specific areas or issues requiring further assessment. The NRA will be completed at least six months before the start of operations.
<p>Casualty Data and Risk Analysis (Attachment E.3)</p>	<p>The Casualty Data and Risk Analysis report assesses casualty data for global trends in the safety of design vessels forecast to call at the terminal. As part of the risk analysis, local casualty data is assessed to identify areas requiring special focus. The report assesses credible hazards to marine operations and the estimated return periods for different casualty types, including cargo release along the marine route or at the terminal.</p> <p>The risk analysis relies on assessments completed for the applicable regions of the BC North Coast and the Prince Rupert area. Further risk mitigations are recommended as required and where practicable.</p>
<p>Vessel Specifications (Attachment E.4)</p>	<p>The Vessel Specifications report describes the specifications for the design LNG carriers and NGL product vessels forecast to call at the terminal.</p> <p>A review of the existing world LNG carrier fleet is provided. The design vessels are common throughout global trade and not unique to the Project. Design vessel characteristics are described and cross-referenced to the Marine Route report and desktop simulation, confirming that the design vessels can safely maneuver between open ocean and the marine terminal.</p> <p>The report describes the evolving regulatory requirements for the design vessels and vessel safety features. The vessel vetting process for the marine terminal is also described.</p>
<p>Terminal Plans and Cargo Transfer (Attachment E.5)</p>	<p>The Terminal Plans and Cargo Transfer report summarizes the marine terminal design criteria, the preliminary design of the marine terminal, and cargo loading from the FLNG to the design vessels. The objectives of the report are to:</p> <ul style="list-style-type: none"> ▪ Provide an overall site plan showing the location of the marine terminals ▪ Describe metocean data recorded near the Site ▪ Describe marine terminal arrangements for transferring cargoes from the FLNG to the design vessels ▪ Describe berthing and mooring provisions for the design vessels ▪ Provide preliminary metocean limits for operations at the marine terminal <p>The report confirms the marine terminal berths and moorings can accommodate the range of design vessels under forecast operating conditions.</p>

Study	Description
<p>Contingency Planning and Hazardous and Noxious Substances (Attachment E.6)</p>	<p>The Contingency Planning and Hazardous and Noxious Substances report describes marine contingency plans for the Project. The report also describes the characteristics of the Project’s forecast cargoes.</p> <p>The objectives of the report are to outline a preliminary contingency plan for incidents from LNG carriers and NGL product vessels in Canadian waters and at the marine terminal.</p> <p>The report also describes the global and Canadian requirements for contingency planning. Contingency plans are required by international conventions such as the International Convention for the Safety of Life at Sea (SOLAS), MARPOL, the International Safety Management Code, and the <i>Canada Shipping Act, 2001</i>.</p>
<p>Terminal Operations Manual (Attachment E.7)</p>	<p>The Terminal Operations Manual report provides the framework for the Project’s Terminal Operations Manual. During operations, the Terminal Operations Manual is provided to design vessels before arrival at the terminal. The Terminal Operations Manual informs the ships’ personnel about important subject matter affecting safety of the design vessels, the marine terminal, and cargo transfer operations.</p> <p>The Terminal Operations Manual will be completed during detailed Project planning and provided to relevant agencies before the start of operations. The Terminal Operations Manual will follow established industry best-practices.</p>

1 **ATTACHMENT E.1 MARINE TRAFFIC**

Ksi Lisims LNG
Navigation Safety Assessment

Marine Traffic

11 October 2023



Disclaimer

This report is not intended to stand alone without reference to the instructions given to Westmar by Ksi Lisims LNG, communications between Westmar and Ksi Lisims LNG, and any other reports, proposals or documents prepared by Westmar for Ksi Lisims LNG under the governing contract between Westmar and Ksi Lisims LNG. To understand the suggestions, recommendations and opinions expressed herein, reference must be made to all relevant documents and communications.

This report has been prepared only for the purposes that are set out in the governing contract between Westmar and Ksi Lisims LNG. The findings, recommendations, suggestions and or opinions expressed in this report are only applicable to the purposes for which the report is expressly provided, and then only to the extent that there has been no material alteration to or variation from the information provided or available to Westmar.

The information and opinions expressed in this report are for the sole use and benefit of Ksi Lisims LNG. No other party may use or rely upon the report or any portion thereof without Westmar's prior written consent, and such use shall be on terms and conditions as Westmar expressly approves. Ownership in and copyright for the contents of the report belong to Westmar. Any use which a third party makes of the report is the sole risk and responsibility of such third party. Westmar accepts no responsibility whatsoever for loss or damages suffered by any third party in relation to use of this report.

Company Details

Westmar Advisors Inc.
700 - 1901 Rosser Avenue
Burnaby, BC, V5C 6R6

T 604 770 4787

info@westmaradvisors.com

Table of Contents

Abbreviations	v
Preface	x
1 Introduction.....	1
2 Regional Marine Traffic	2
2.1 Marine Route	2
2.2 Vessels in the Region	2
2.2.1 Information Sources.....	2
2.2.2 Vessel Types and Sizes	4
2.3 Regional Traffic Statistics	4
2.3.1 Traffic Patterns.....	4
2.3.2 Traffic Volumes.....	10
2.3.3 Project Marine Traffic.....	15
2.4 Special Operational Areas	16
2.4.1 Military Operations	16
2.4.2 Offshore Exploration and Exploitation Areas	17
2.4.3 Seaplane Operations.....	18
2.5 Regional Network Focal Points	18
2.5.1 Triple Islands.....	19
2.5.2 Chatham Sound South	19
2.5.3 Chatham Sound North	20
2.6 Fishing Activities	20
2.7 Alternative Routes	20
3 Marine Terminal Area Traffic.....	21
3.1 Traffic in Portland Canal	21
3.2 Local Fishing and Recreational Activities	22
3.3 Traffic Support Services	22
References.....	23

List of Tables

Table 1 - Vessel types	4
Table 2 - Annual trips by vessel type.....	11
Table 3 - Annual trips by fence location	14
Table 4 – Average number of trips per week by fence location.....	14

List of Figures

Figure 1 - Overview of the selected marine route (Canadian Hydrographic Service Chart 3002, depths are in fathoms and feet).....	2
Figure 2 - Transport Canada survey of non-AIS and AIS-equipped vessels [3]	3
Figure 3 - Regional vessel traffic – selected marine route overview (2019 data)	5
Figure 4 - Cargo vessel traffic patterns (2019 data)	6
Figure 5 - Fishing vessel traffic patterns (2019 data).....	7
Figure 6 - Military / government vessel traffic patterns (2019 data).....	7
Figure 7 - Passenger vessel traffic patterns (2019 data).....	8
Figure 8 - Sailing / pleasure craft vessel traffic patterns (2019 data).....	8
Figure 9 – Special / miscellaneous vessel traffic patterns (2019 data).....	9
Figure 10 - Tanker traffic patterns (2019 data).....	9
Figure 11 - Tug traffic patterns (2019 data).....	10
Figure 12 - Annual trips by vessel type	11
Figure 13 - Regional traffic by vessel type and month	12
Figure 14 - AIS fence locations (2019 data).....	13
Figure 15 - Traffic by vessel type (2019 data, orange circle proportional to traffic volume).....	15
Figure 16 – Canadian military exercise areas [13]	17
Figure 17 – North Coast shellfish aquaculture sites [15]	18
Figure 18 – Marine network focal points (2019 data).....	19
Figure 19 - Vessel traffic in Portland Canal.....	21
Figure 20 - Annual vessel traffic past the Site (2019 data)	22

Abbreviations

Abbreviation	Description
°C	degrees Celsius
ABS	American Bureau of Shipping
ADCP	acoustic doppler current profiler
AIS	automatic identification system
AIS ATON	automatic identification system aid to navigation
AK	Alaska
ANSI	American National Standards Institute
ARI	average recurrence interval
ATON	aids to navigation
BC	British Columbia
BCCP	British Columbia Coast Pilots Ltd.
BCER	BC Energy Regulator
BNWAS	bridge navigational watch alarm system
BOG	boil off gas
BV	Bureau Veritas
CCG	Canadian Coast Guard
CHS	Canadian Hydrographic Services
CMB	continuous marine broadcast
CPAs	Compulsory Pilotage Areas
DAS	docking assist system
deg	degree
DFO	Fisheries and Oceans Canada
DNV	Det Norske Veritas
dwt	deadweight tonnage
EA	environmental assessment
ECCC	Environment and Climate Change Canada
ECDIS	electronic chart display and information system
EDG	emergency diesel generators
EEBD	Emergency Escape Breathing Device
EMSA	enhanced maritime situation awareness
ENC	electronic navigational chart
EOC	Emergency Operations Centre
EPIRB	emergency position-indicating radio beacon
ERS	emergency release system

Abbreviation	Description
ESD	emergency shut down
ETA	estimated time of arrival
EU	environmental unit
FEED	front-end engineering design
FFA	fire fighting appliances
FLNG	floating liquefaction, storage, and off-loading barge
FMBS	full mission bridge simulation
FMO	Federal Monitoring Officer
FSA	Formal Safety Assessment
FSRU	floating storage and regassification units
GMDSS	Global Maritime Distress, and Safety System
GNSS	Global Navigation Satellite System
GTT	Gaztransport and Technigaz
HFO	heavy fuel oil
HNS	hazardous and noxious substances
Hs	significant wave height
IACS	International Association of Classification Societies
IALA	International Association of Marine Aids to Navigation and Lighthouse Authorities
ICS	Incident Command System
IGC Code	<i>International Code for the Construction and Equipment of Ships Carrying Liquefied Gases in Bulk</i>
ILO	International Labour Organization
IMO	International Maritime Organization
ISGOTT	<i>International Safety Guide for Oil Tankers and Terminals</i>
ISM	International Safety Management
ISPS	<i>International Ship and Port Facility Security Code</i>
kHz	kilohertz
km	kilometre
kn	knot
LBP	length between perpendiculars
LFL	lower flammability limit
LLWLT	lower, low water, large tide
LNG	liquefied natural gas
LOA	length overall
LOS	level of service
LPG	liquefied petroleum gas
LR	Lloyd's Register

Abbreviation	Description
LSA	life-saving appliances
LSIR	location specific individual risk
LTA	line throwing appliance
m	metre
m	metres per second
m ²	square metres
m ³	cubic metres
m ³	cubic metres
m ³ / hour	cubic metres per hour
MARPOL	<i>International Convention for the Prevention of Pollution of Ships</i>
MCTS	Marine Communications and Traffic Services
MDO	marine diesel oil
MGO	marine gas oil
MOF	material off-loading facility
MOU	Memorandum of Understanding
MSI	Marine Safety Inspectors
MSOC	Marine Security Operations Centre
MTBE	methyl tertiary butyl ether
mtpa	million tonnes per annum
NASP	National Surveillance Aerial Program
NAVTEX	Narrow Band Direct Printing Telegraphy
NAVWARN	navigational warnings
NGL	natural gas liquid
NK	Nippon Kaiji Kyokai
NLG	Nisga'a Lisims Government
NLS	Noxious Liquid Substances
NOA	notice of arrival
North Coast	north coast of British Columbia
NOTMAR	Notices to Mariners
NRA	BCCP / PPA Navigational Risk Assessment
NSA	navigation safety assessment
NW	northwest
OCIMF	Oil Companies International Marine Forum
ODAS	ocean data acquisition system
OGAA	<i>Oil and Gas Activities Act</i>
OPP	Oceans Protection Plan

Abbreviation	Description
OPRC	<i>International Convention on Oil Pollution Preparedness, Response and Co-operation</i>
OSC	On-Scene Commander
P&I	protection and indemnity (insurance)
P&I	protection and indemnity
PAH	polycyclic aromatic hydrocarbons
PAIR	Pre-Arrival Information Reports
PIANC	World Association for Waterborne Transport Infrastructure
PMS	planned maintenance system
PORCP	National Places of Refuge Contingency Plan
PPA	Pacific Pilotage Authority
PPO	Pollution Prevention Officer
PPU	portable pilot units
PRPA	Prince Rupert Port Authority
PRPRCP	<i>Pacific Region Places of Refuge Contingency Plan</i>
PSC	Port State Control
QCDC	quick connect disconnect couplers
QRA	quantitative risk assessment
QRH	quick release hooks
QSCS	Quality System Certification Scheme
racon	radar beacon
RNC	raster navigational chart
RO	recognized organization (with respect to flag state affairs)
RO	response organization (with respect to spill response)
RT	radiotelephony
s	seconds
SAR	search and rescue
SIGTTO	Society of International Gas Tanker and Terminal Operators
SIRE	Ship Inspection Report Programme
SMPEP	Shipboard Marine Pollution Emergency Plan
SOLAS	<i>International Convention for the Safety of Life at Sea (SOLAS), 1974</i>
SOPEP	Shipboard Oil Pollution Emergency Plan
SOPF	Ship-source Oil Pollution Fund
SSL	ship-shore link
STCW	<i>International Convention on Training, Certification, and Watchkeeping for Seafarers</i>
SW	southwest
SWL	safe working load

Abbreviation	Description
t	metric tonne (equal to 1,000 kilograms)
TCMSS	Transport Canada Marine Safety and Security
TERMPOL	Technical Review Process of Marine Terminal Systems and Transshipment Sites
TOM	Terminal Operations Manual
Tp	peak wave period
TSB	Transportation Safety Board of Canada
UKC	underkeel clearance
US	United States
V-ATON	virtual aid to navigation
VDR	voyage data recorder
VHF	very high frequency
VLSFO	very low sulphur fuel oil
VTS	Vessel Traffic Services
WCMRC	Western Canada Marine Response Corporation

Preface

A Navigation Safety Assessment (NSA) is part of the Application. The NSA is an opportunity to review the Ksi Lisims LNG Project and determine whether additional resources (e.g., pilots), controls or infrastructure (e.g., navigational aids) are required and when they need to be in place. The NSA studies make-up Appendix E and findings inform Section 9 Malfunctions and Accidents and other sections (e.g., Section 7.11 Marine Use). Section 9.1.2 Planning provides a list and high-level description of the NSA studies. Additional navigation simulations will be completed before the start of operations and will be the subject of approval conditions.

1 Introduction

The *Marine Traffic Report* is part of the Navigation Safety Assessment (NSA) for the Ksi Lisims LNG – Natural Gas Liquefaction and Marine Terminal Project (the Project). An overview of the Project, including the selected marine route for liquefied natural gas (LNG) carriers and natural gas liquid (NGL) product vessels, is provided in the *Marine Route Report* [1].

The *Marine Traffic Report* describes:

- The types and number of vessels operating in the region
- The forecast number of LNG carriers and NGL product vessels calling at the marine terminal
- Regional focal points and areas of crossing traffic

The selected marine route is used by vessels travelling to Prince Rupert, BC and Stewart, BC. Forecast LNG carrier and NGL product vessel traffic creates no new traffic focal points. The forecast traffic results in an additional three vessel transits per week through Brown Passage, and an increase in vessel traffic in Portland Inlet and Portland Canal. The increase in traffic is manageable relative to other areas of the BC coast with similar size vessels and greater traffic density.

2 Regional Marine Traffic

2.1 Marine Route

The selected marine route is shown in Figure 1 and described in the *Marine Route Report* [1]. The design LNG carriers and NGL product vessels are described in the *Vessel Specifications Report* [2].

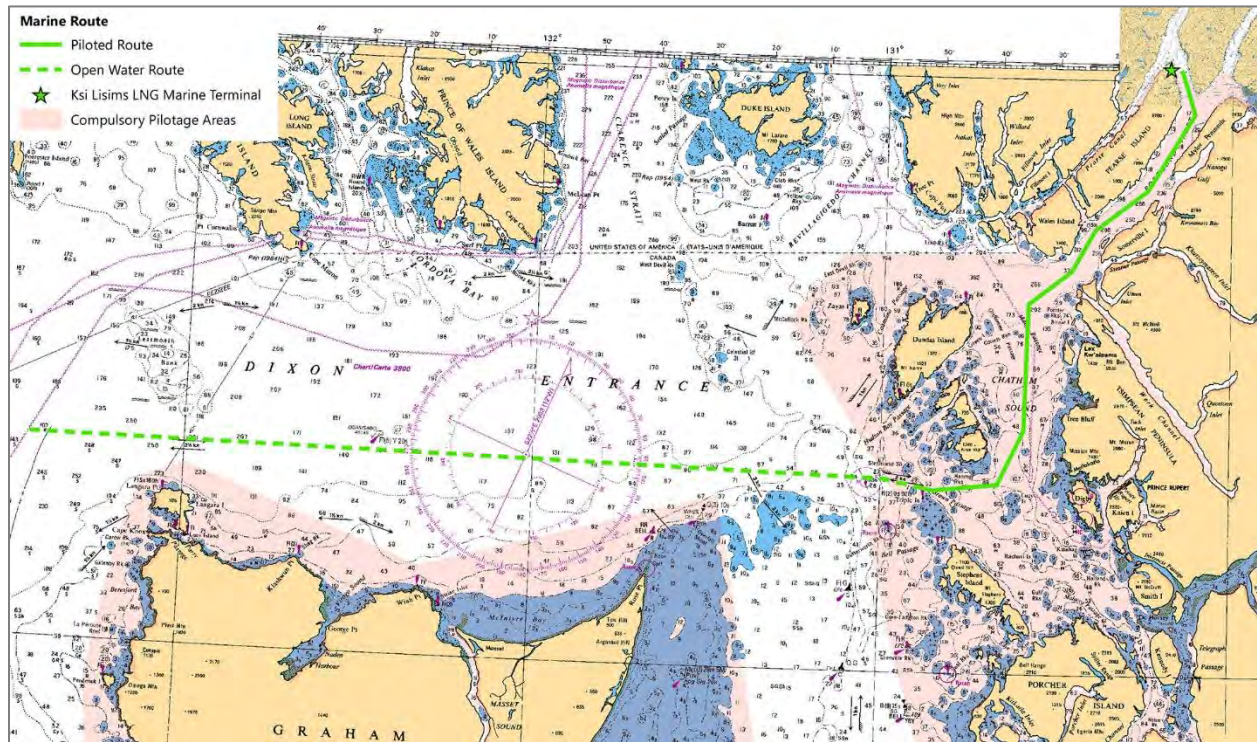

Figure 1 - Overview of the selected marine route (Canadian Hydrographic Service Chart 3002, depths are in fathoms and feet)

The selected marine route has been divided into three sections:

- 1) **Open ocean to the Triple Island pilot boarding station** – The marine route from open ocean (i.e., Canada’s territorial 12 nm limit), east through Dixon Entrance, south of Learmonth Bank and north of Haida Gwaii, to the Triple Islands pilot boarding station
- 2) **Triple Island pilot boarding station to Portland Inlet** – The marine route from the Triple Island pilot boarding station, through Brown Passage, north into Chatham Sound, passing north of Lucy Islands, and north through Main Passage to the entrance of Portland Inlet
- 3) **Portland Inlet to Portland Canal** – The marine route through Portland Inlet, turning north into Portland Canal, arriving at the marine terminal at the northern end of Pearse Island

2.2 Vessels in the Region

2.2.1 Information Sources

The *Marine Traffic Report* uses these data sources to assess regional traffic:

- Automatic identification system (AIS) data for the years 2019 and 2021 purchased from Exmile Solutions Ltd (“MarineTraffic”)
- Pilot assignments provided by the Pacific Pilotage Authority (PPA)
- Information on vessel traffic not fitted with AIS from a Transport Canada National Surveillance Aerial Program (NASP) survey [3]

2.2.1.1 AIS Vessel Data

The *International Convention for the Safety of Life at Sea (SOLAS)* [4] established by the International Maritime Organization (IMO) and specifically *SOLAS regulation V/19 - Carriage requirements for shipborne navigational systems and equipment* [5] requires all ships of 300 gross tonnage and upwards engaged on international voyages, cargo ships of 500 gross tonnage and upwards not engaged on international voyages and all passenger ships be fitted with AIS. The requirement became effective for all ships in 2004. The SOLAS requirements are promulgated in Canada in the Navigation Safety Regulations, 2020 under the *Canada Shipping Act, 2001*.

Analysing AIS data is an accurate and efficient method for assessing the movement of large commercial vessels. Vessels with AIS broadcast their position and other information to other vessels and receiving stations. AIS data is collected by land-based stations and satellites, with coverage worldwide in real time. Several companies store and compile AIS data. For this report, AIS data was purchased for the region of the marine route. Due to issues affecting global shipping in recent years, pre-COVID data from 2019 and post-COVID data from 2021 are both assessed.

2.2.1.2 Non-AIS Vessel Data

Smaller recreational and fishing vessels may have AIS installed voluntarily. An estimate of the number of vessels without AIS on the Norther Coast has been made based on a Transport Canada NASP survey [3]. The survey included 25 surveillance flights in the Prince Rupert region from May 2019 to April 2020. The survey used a Transport Canada aircraft equipped to photograph vessels and detect vessels with AIS.

The results from the Transport Canada survey are in Figure 2. Of the 357 vessels sighted, 226 were not fitted with AIS and 131 had AIS, for an overall non-AIS / AIS vessel ratio of 1.7. These findings have been used to scale AIS vessel traffic data to account for non-AIS vessels (see section 2.3.2.2).

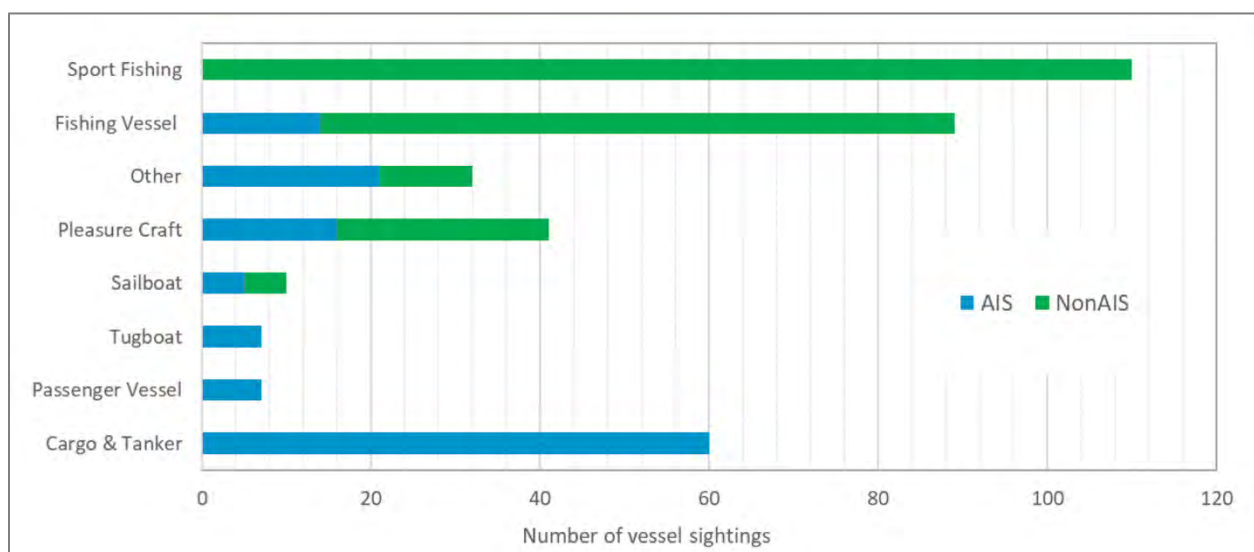

Figure 2 - Transport Canada survey of non-AIS and AIS-equipped vessels [3]

2.2.2 Vessel Types and Sizes

Vessels in the region have been sorted by type into the groupings in Table 1. These classifications are aligned with the major vessel classifications in AIS data.

Table 1 - Vessel types

Vessel Type	Description / Examples	Size Range - Vessel Length [m] ^a		
		Smallest	Largest	Average ^b
Fishing	Trawlers, commercial fishing vessels, and private vessels	4	160	22
Tug	Escort tugs, harbour tugs, tugs towing barges and log booms	6	86	29
Sailing / pleasure craft	Sailing and power yachts, and some sportfishing vessels	3	76	13
Military and government	Navy, police, coastguard, search, and rescue (SAR), research vessels, pilot, port tender, and anti-pollution vessels	6	182	23
Passenger	BC Ferries and Alaska State ferry vessels, cruise ships, water taxis	6	348	141
Special / miscellaneous	Dredgers, dive vessels, heavy-lift, buoy-laying vessels, cable-laying vessels	7	216	32
Cargo	Container vessels, bulk carriers, and break-bulk vessels	28	367	235
Tanker	Product and chemical tankers	133	230	201

NOTES:

- Based on AIS data records. Accounting for non-AIS vessels would reduce the average and smallest vessel size for fishing and pleasure craft.
- Average length by number of vessel trips throughout the year, not by number of unique vessels.

2.3 Regional Traffic Statistics

2.3.1 Traffic Patterns

Recordings of vessel position every five minutes, taken from AIS data, have been converted to vessel tracks sorted by vessel type. Figures below illustrate traffic routes and patterns for different vessel types. An overview of all vessel tracks is shown in Figure 3.

The PPA provides records of all pilotage assignments. PPA records can be sorted by location and vessel type. Piloted movements from the Triple Island pilot station in 2021 were compared with AIS data for tankers through Dixon Entrance. There are 72 AIS tracks for tankers entering through Dixon Entrance and 72 records of pilot callouts from Triple Island for the same vessel type, demonstrating good correlation between PPA and AIS data.

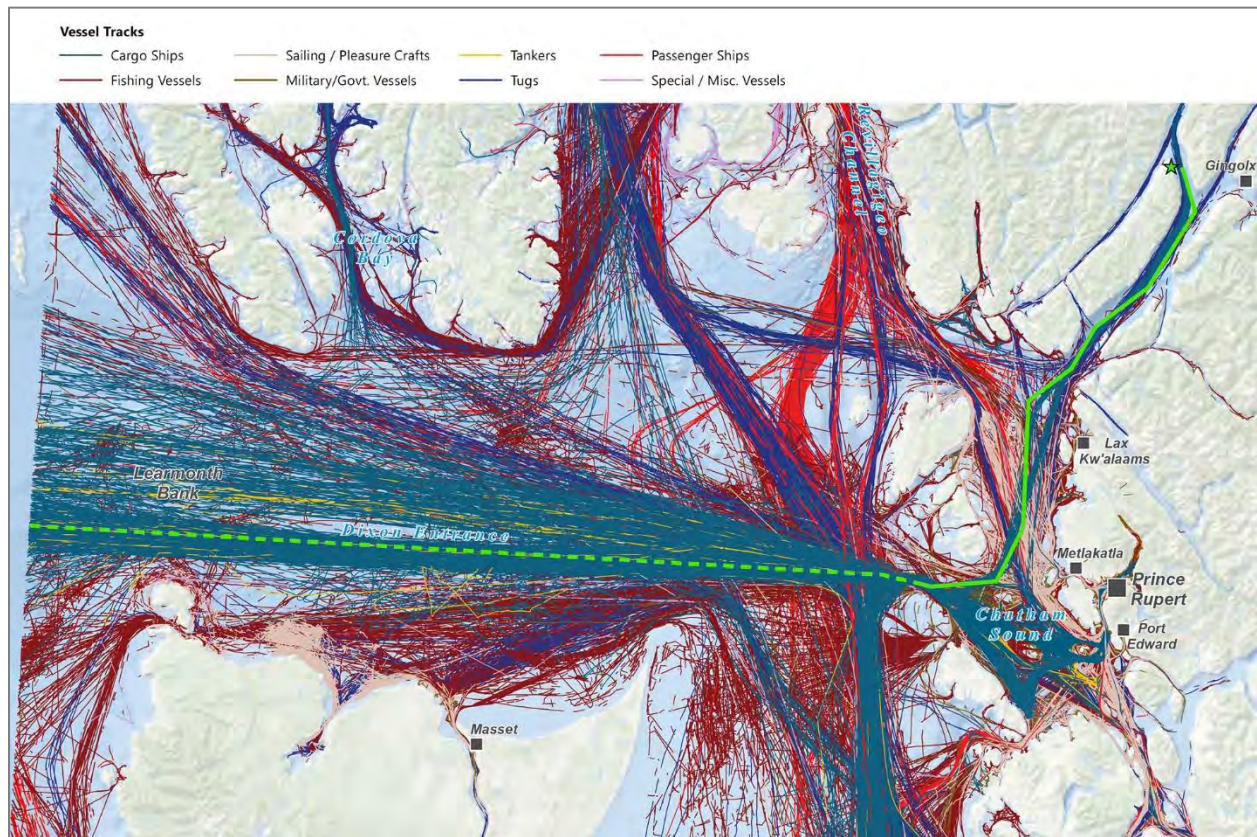

Figure 3 - Regional vessel traffic – selected marine route overview (2019 data)

Regional traffic routes and patterns are illustrated in these figures:

- Figure 4 - Cargo vessel traffic patterns
- Figure 5 - Fishing vessel traffic patterns
- Figure 6 - Military / government vessel traffic patterns
- Figure 7 - Passenger vessel traffic patterns
- Figure 8 - Sailing / pleasure craft vessel traffic patterns
- Figure 9 – Special / miscellaneous vessel traffic patterns
- Figure 10 - Tanker traffic patterns
- Figure 11 - Tug traffic patterns

Observations from the above figures include:

- Brown Passage is a focal point for most vessels travelling east-west between Chatham Sound and Dixon Entrance
- The principal location of crossing traffic on the marine route is near the Triple Island pilot boarding station
- Cargo vessels follow well-defined routes, primarily between Dixon Entrance or Hecate Strait and Prince Rupert (Figure 4). Most cargo vessels transiting Dixon Entrance pass south of Learnmonth Bank
- Fishing activity is dispersed throughout the region and generally not near the marine route (Figure 5).
- Government and military vessels are concentrated between Prince Rupert and Triple Island pilot station due to pilot vessels and Canadian Coast Guard or SAR activity (Figure 6).

- Passenger vessel movements are primarily north-south, past Triple Islands and through Chatham Sound (Figure 7).
- Sailing / pleasure craft activity is primarily north-south through Chatham Sound. There are also movements close to the north coast of Haida Gwaii, but not near the marine route (Figure 8).
- Tanker traffic to Prince Rupert is through Dixon Entrance (Figure 10).
- Tug traffic follows well-defined routes but is dispersed. The variation in routes is due to the nature of the industries and communities supported by tugs and barges and a preference to transit sheltered routes which vary depending on local weather patterns (Figure 11).

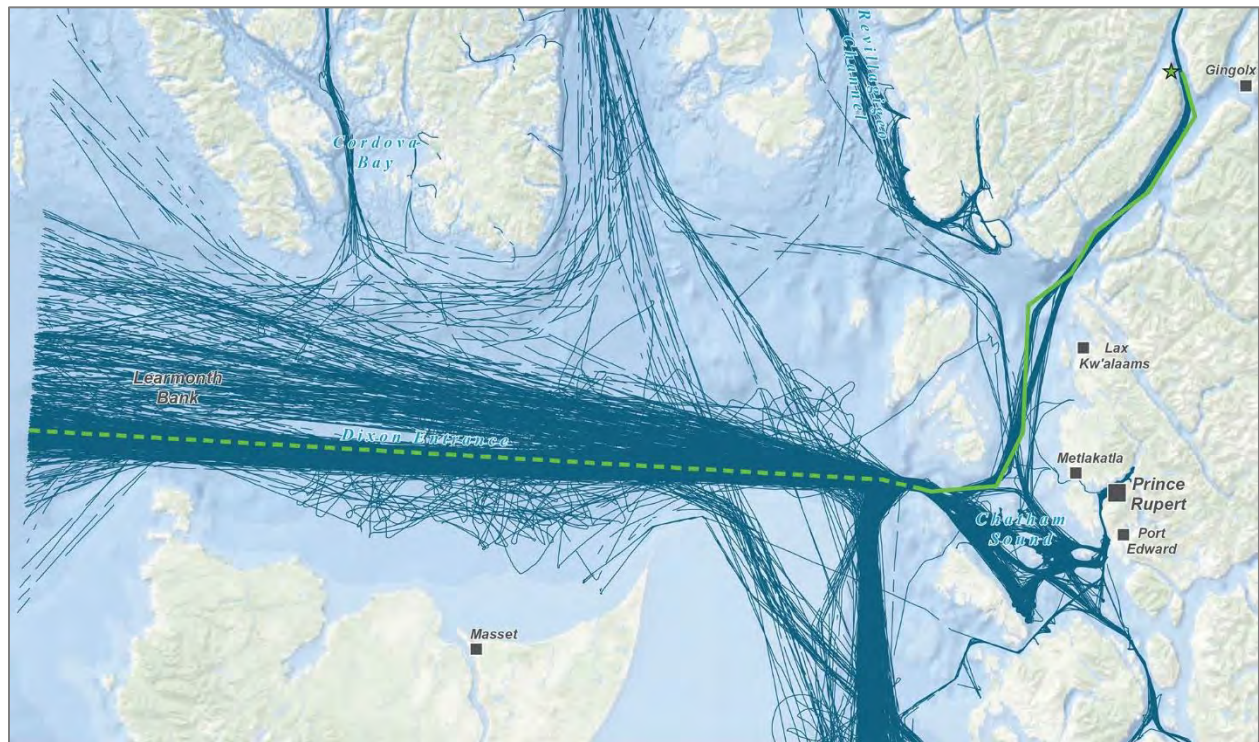

Figure 4 - Cargo vessel traffic patterns (2019 data)

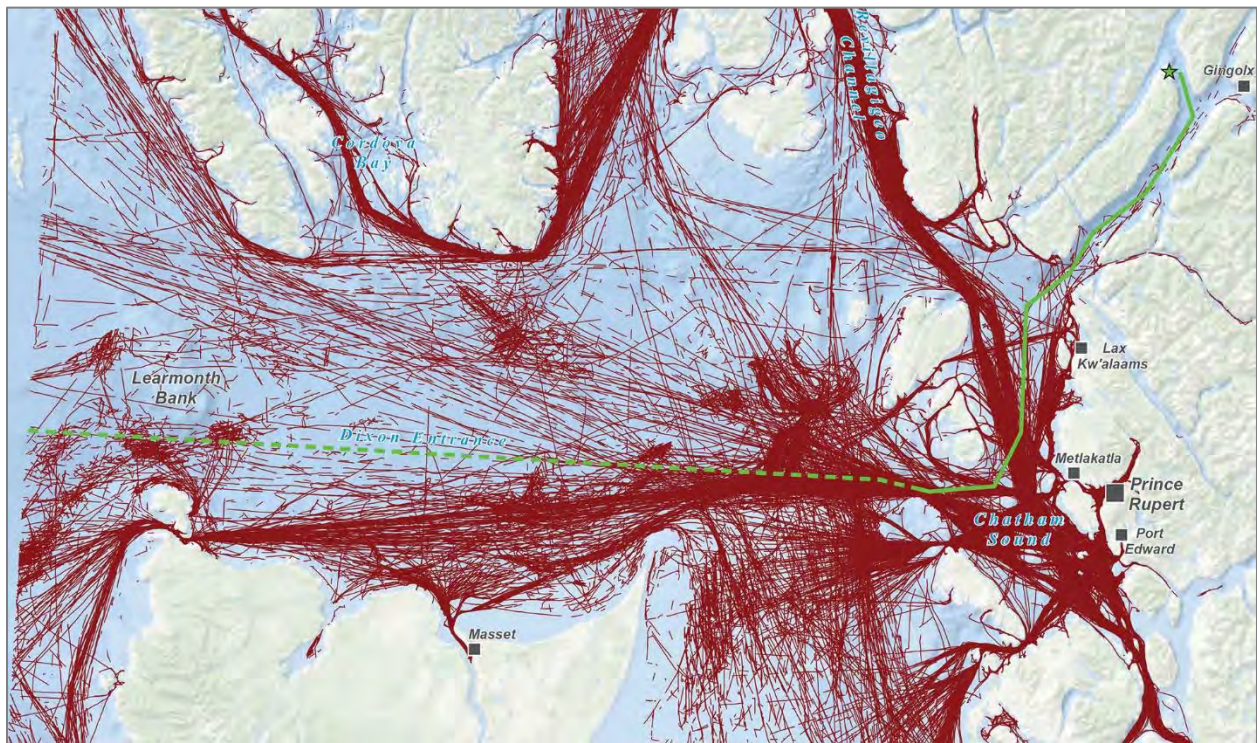

Figure 5 - Fishing vessel traffic patterns (2019 data)

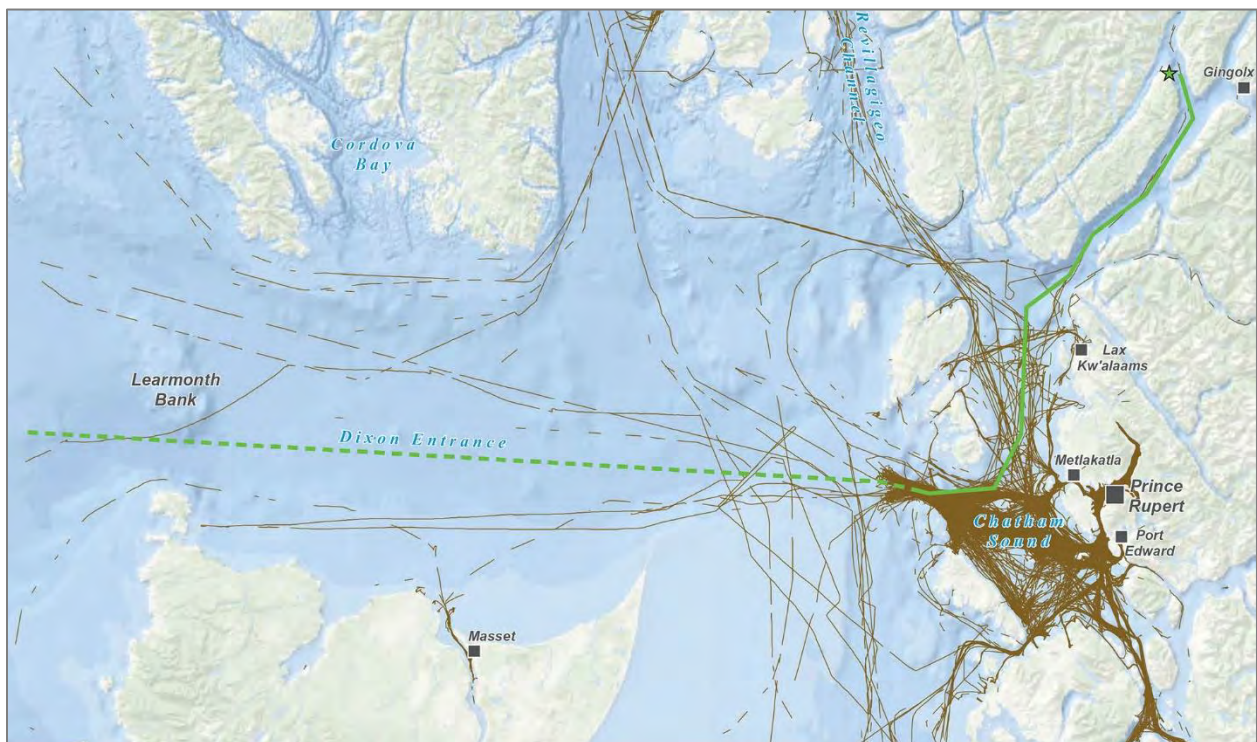

Figure 6 - Military / government vessel traffic patterns (2019 data)

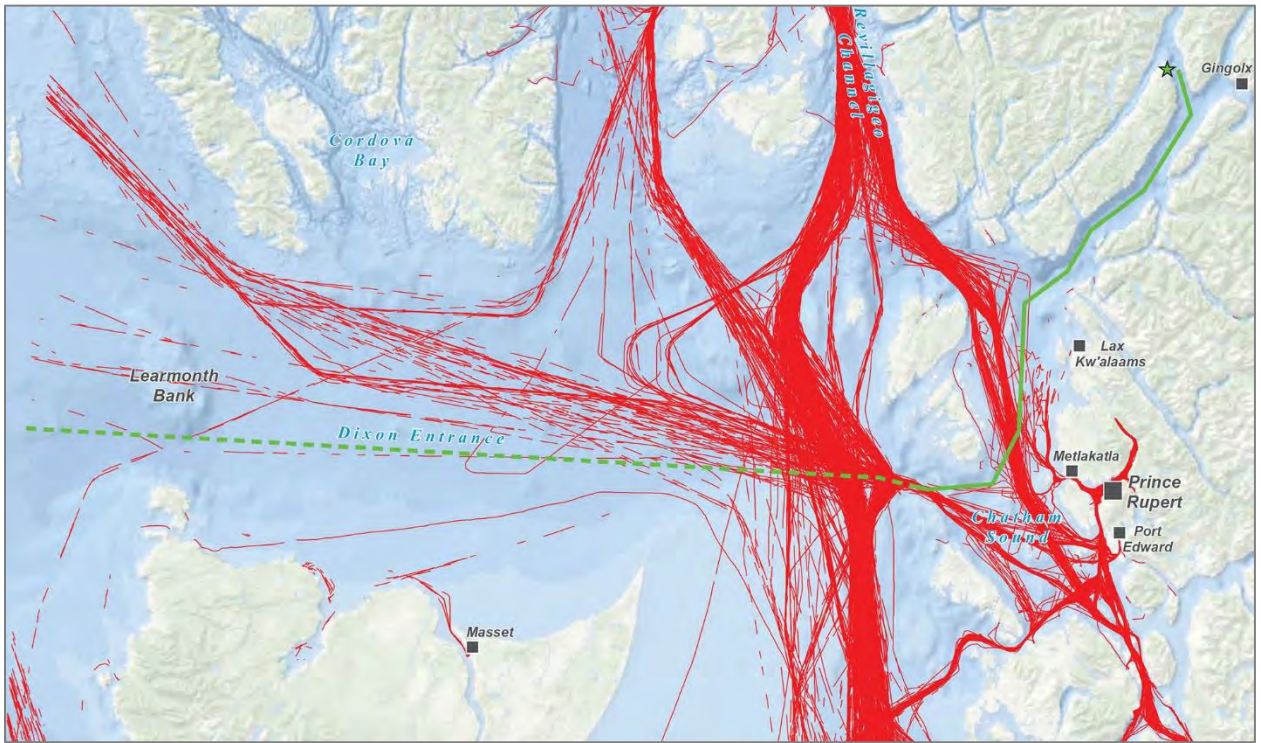

Figure 7 - Passenger vessel traffic patterns (2019 data)

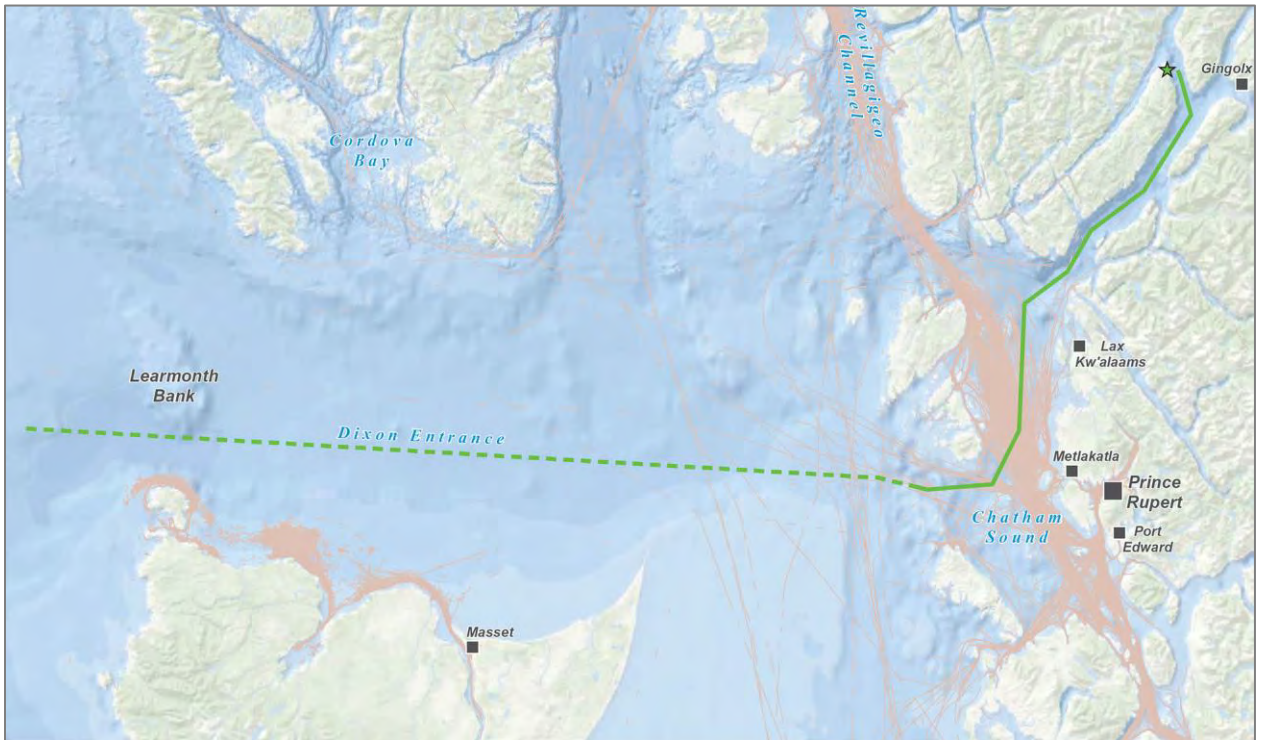

Figure 8 - Sailing / pleasure craft vessel traffic patterns (2019 data)

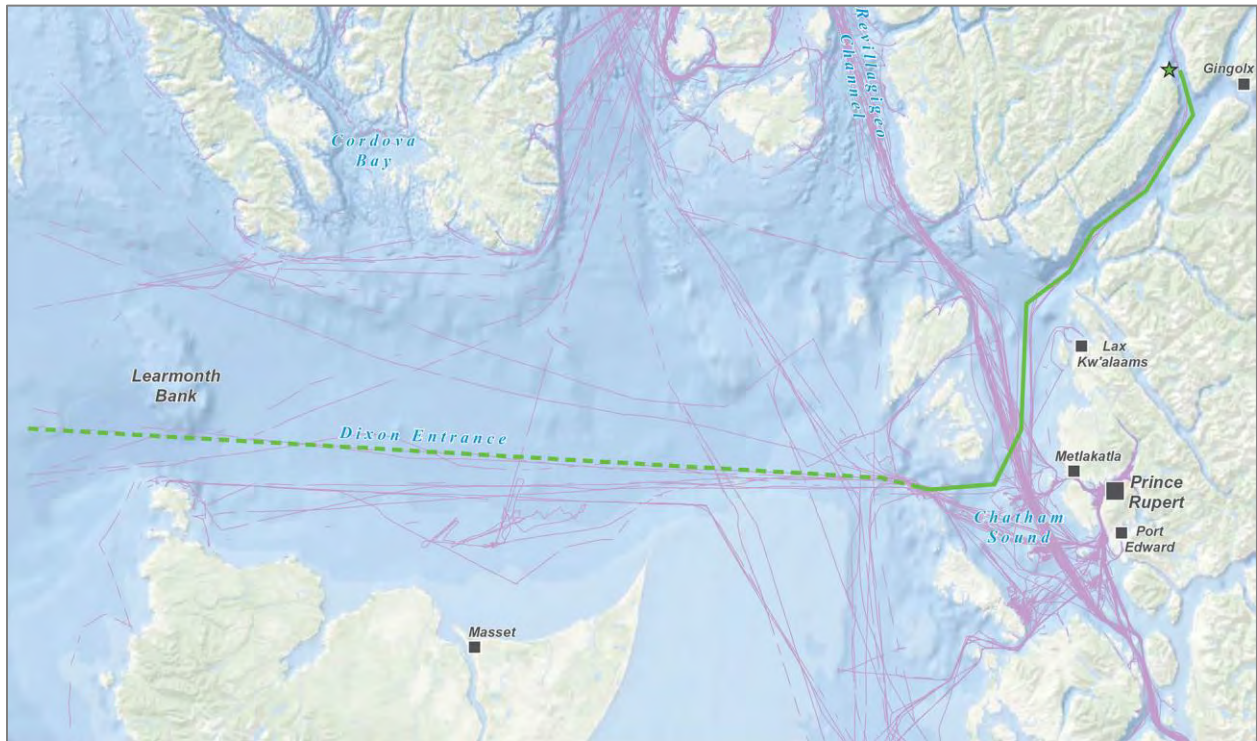

Figure 9 – Special / miscellaneous vessel traffic patterns (2019 data)

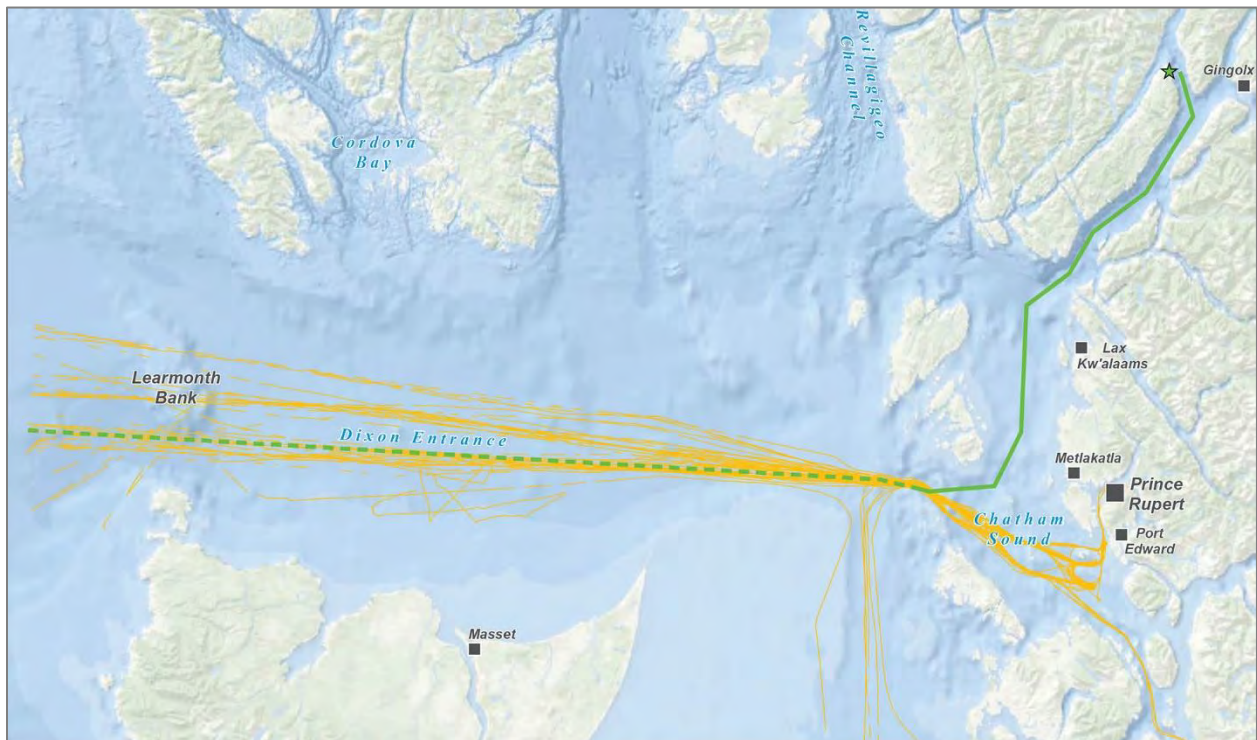

Figure 10 - Tanker traffic patterns (2019 data)

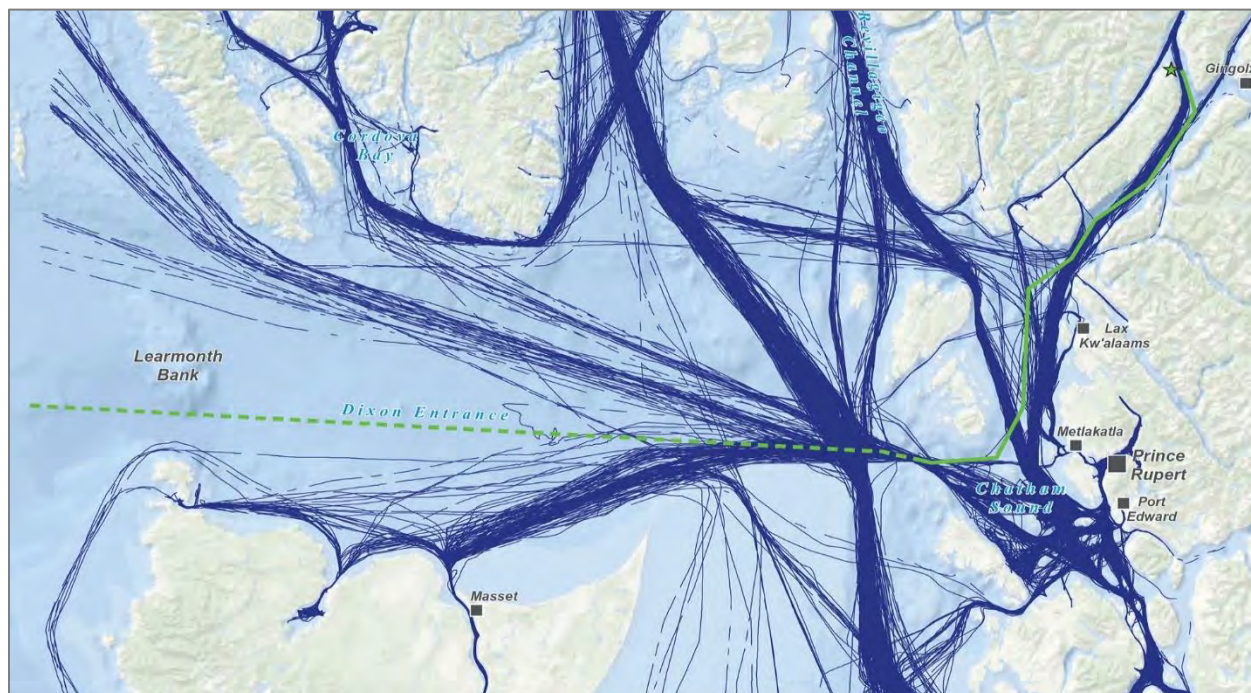

Figure 11 - Tug traffic patterns (2019 data)

2.3.2 Traffic Volumes

2.3.2.1 Annual Variations

Seasonal and annual variation of vessel traffic is shown in Figure 12. The numbers presented are trips passing through Triple Islands and Chatham Sound. A vessel passing through Brown Passage to Prince Rupert and back through Brown Passage to Dixon Entrance would be counted as two trips through Brown Passage. Due to their large volume, fishing vessels and sailing / pleasure craft in Figure 12 are plotted on a second vertical axis.

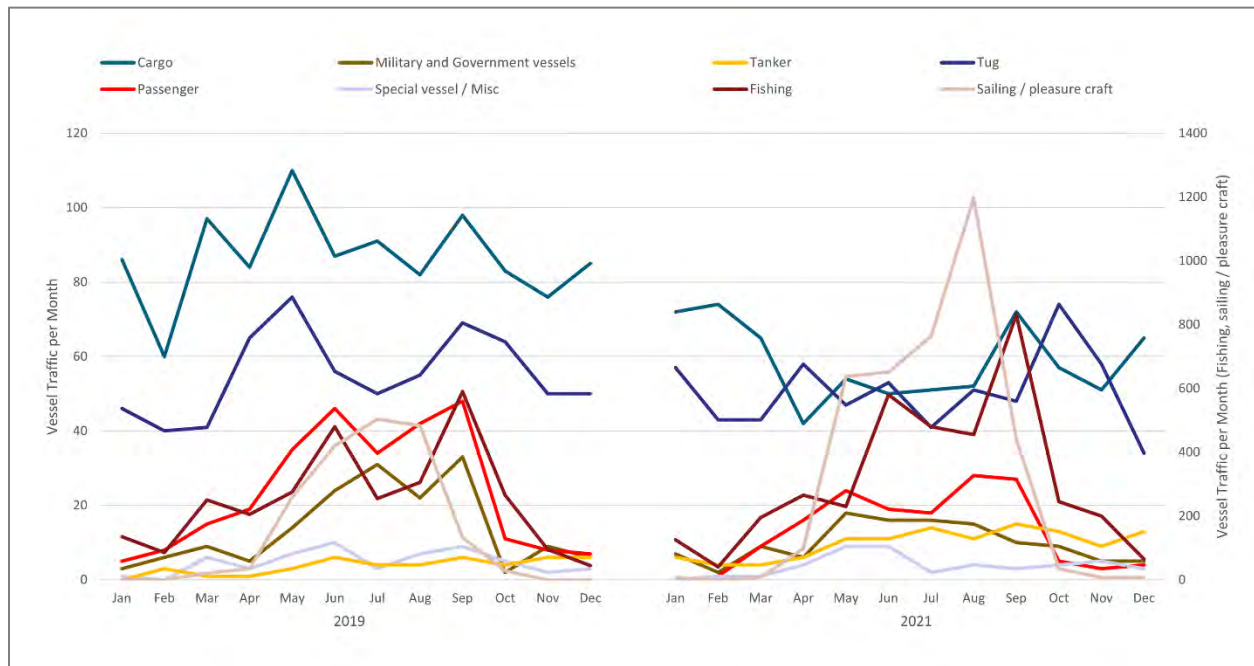

Figure 12 - Annual trips by vessel type

AIS data for Triple Islands and Chatham Sound for 2019 and 2021 is sorted by vessel type and compared in Table 2.

Table 2 - Annual trips by vessel type

Vessel Type	2019	2021	Difference (2021 to 2019)
Cargo	2,517	2,301	91%
Fishing	1,013	1,118	110%
Military and government	190	166	87%
Passenger	1,061	329	31%
Sailing / pleasure craft	291	591	203%
Special vessel / miscellaneous	87	88	101%
Tanker	108	288	267%
Tug	1,541	1,331	86%
Total	6,808	6,225	91%

There were more trips in 2019 than 2021, with the following primary variations by vessel type:

- Passenger trips were significantly reduced in 2021 compared to 2019 due to fewer cruise ships operating because of COVID [6]
- Tanker traffic is greater in 2021 due to commencement of operations at Pembina’s Prince Rupert Terminal on Watson Island near Prince Rupert [7]

- There was an increase in sailing / pleasure craft activity in 2021 when Canadian waters reopened to visitors from the United States after being closed due to COVID [8]. COVID travel restrictions also saw an increase in domestic new boaters through 2020 into 2021 [9]
- Fishing activity increased in 2021 relative to 2019

2.3.2.2 Estimate of Existing Vessel Traffic

To provide a conservative estimate of existing vessel traffic, the largest of the 2019 and 2021 data sets for each vessel type at each location considered were selected. As described in Section 2.2.1.2 types of vessels were scaled to account for vessels not equipped with AIS. Fishing vessels were scaled by a factor of five, and sailboats / pleasure craft were scaled by a factor of seven. The resulting AIS dataset in Figure 13 is considered a conservative representation of the existing vessel traffic, including AIS and non-AIS-equipped vessels. Due to their large volume, fishing vessels and sailing / pleasure craft in Figure 13 are plotted on a second vertical axis.

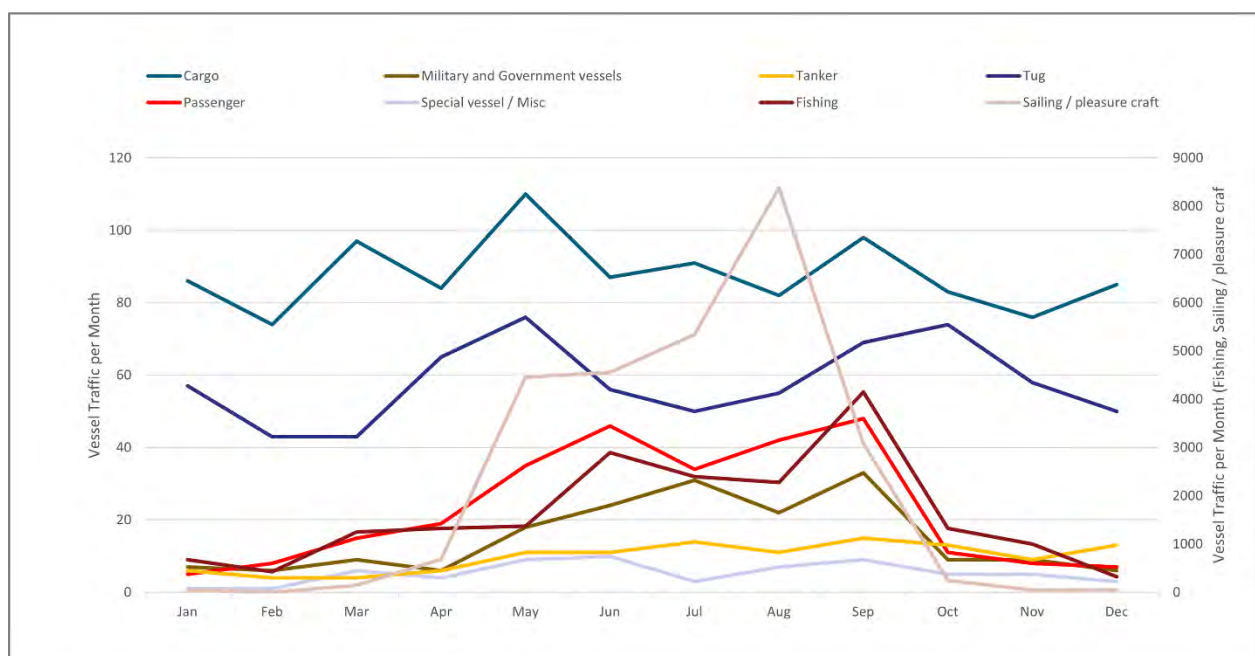

Figure 13 - Regional traffic by vessel type and month

2.3.2.3 Seasonal Variations

These types of vessel traffic increase on the Norther Coast during summer months:

- Sailing / pleasure craft traffic increases in the summer and is largely absent during the winter
- Passenger vessel traffic increases in the summer, when cruise ships are active, compared to winter when only BC Ferries, the Alaska State Ferry service, and smaller water taxis are operational
- Fishing activity is higher in the summer compared to winter

Traffic from tugs, cargo, tankers, and military / government vessels, has smaller seasonal variations.

2.3.2.4 Marine Route Traffic

The AIS dataset can be further analysed to count vessels crossing at locations (or “fences”) along the marine route. Fence locations are shown in Figure 14 and include:

- DE-W Dixon Entrance – West
- TI-W Triple Islands – West
- TI-N Triple Islands – North
- TI-S Triple Islands – South
- BP Brown Passage
- CS-N Chatham Sound – North
- PI Portland Inlet
- PC Portland Canal

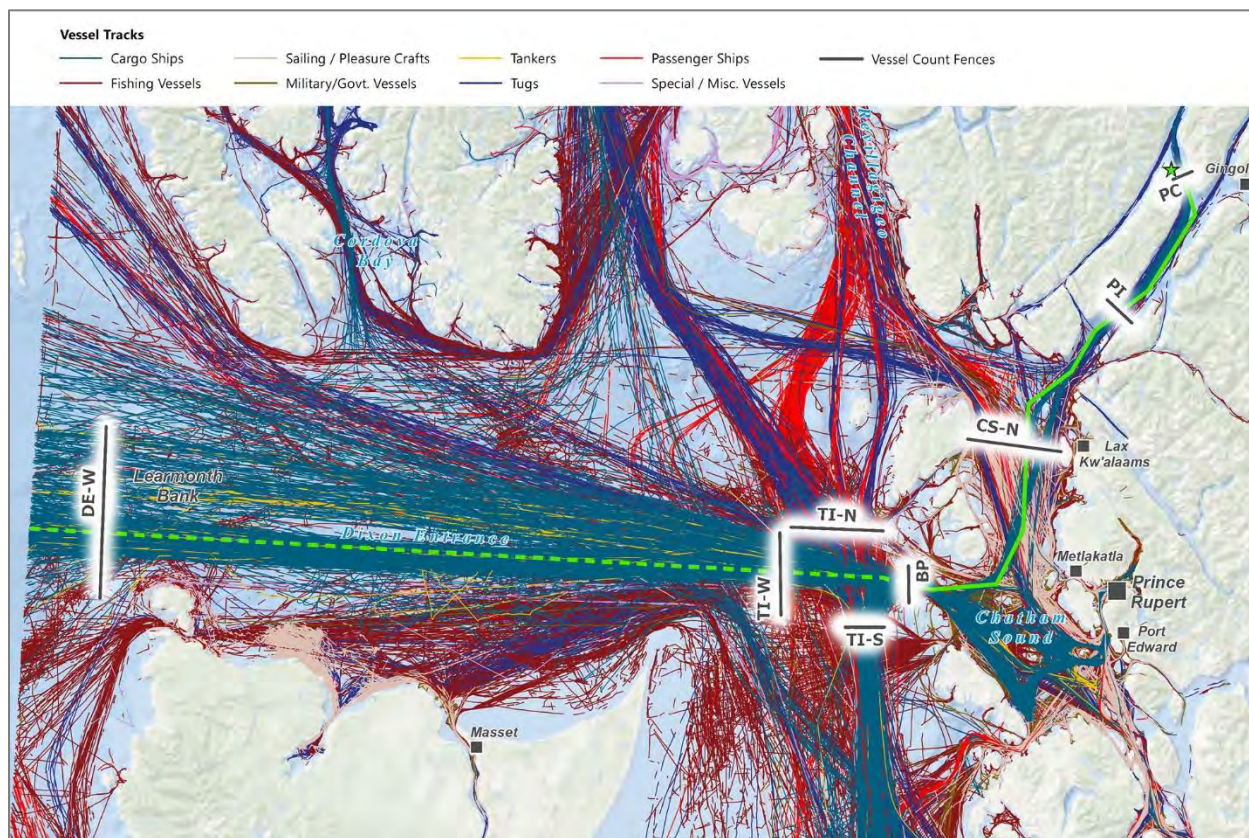

Figure 14 - AIS fence locations (2019 data)

The direction vessels travel through each fence is ignored, with each crossing of a fence considered a separate trip. The number of annual trips is presented in Table 3 and Figure 15. The average number of weekly trips is provided in Table 4.

Table 3 - Annual trips by fence location

Vessel Type	DE-W	TI-W	TI-N	TI-S	BP	CS-N	PI	PC
Cargo	424	655	28	456	958	81	31	29
Fishing	205	1,065	480	330	1,175	2,580	15	5
Military and government	7	8	10	17	139	36	4	3
Passenger	5	65	374	339	60	218	0	0
Sailing / pleasure craft	21	42	140	84	56	3,794	7	0
Special / miscellaneous	5	10	7	14	14	42	5	5
Tanker	72	106	1	12	117	0	0	0
Tug	4	137	315	325	146	516	56	50
Total	743	2,088	1,355	1,577	2,665	7,267	118	92

Table 4 – Average number of trips per week by fence location

Vessel Type	DE-W	TI-W	TI-N	TI-S	BP	CS-N	PI	PC
Cargo	8.2	12.6	0.5	8.8	18.4	1.6	0.6	0.6
Fishing	3.9	20.5	9.2	6.3	22.6	49.6	0.3	0.1
Military and government	0.1	0.2	0.2	0.3	2.7	0.7	0.1	0.1
Passenger	0.1	1.3	7.2	6.5	1.2	4.2	0.0	0.0
Sailing / pleasure craft	0.4	0.8	2.7	1.6	1.1	73.0	0.1	0.0
Special / miscellaneous	0.1	0.2	0.1	0.3	0.3	0.8	0.1	0.1
Tanker	1.4	2.0	0.0	0.2	2.3	0.0	0.0	0.0
Tug	0.1	2.6	6.1	6.3	2.8	9.9	1.1	1.0
Total	14.3	40.2	26.1	30.3	51.3	139.8	2.3	1.8

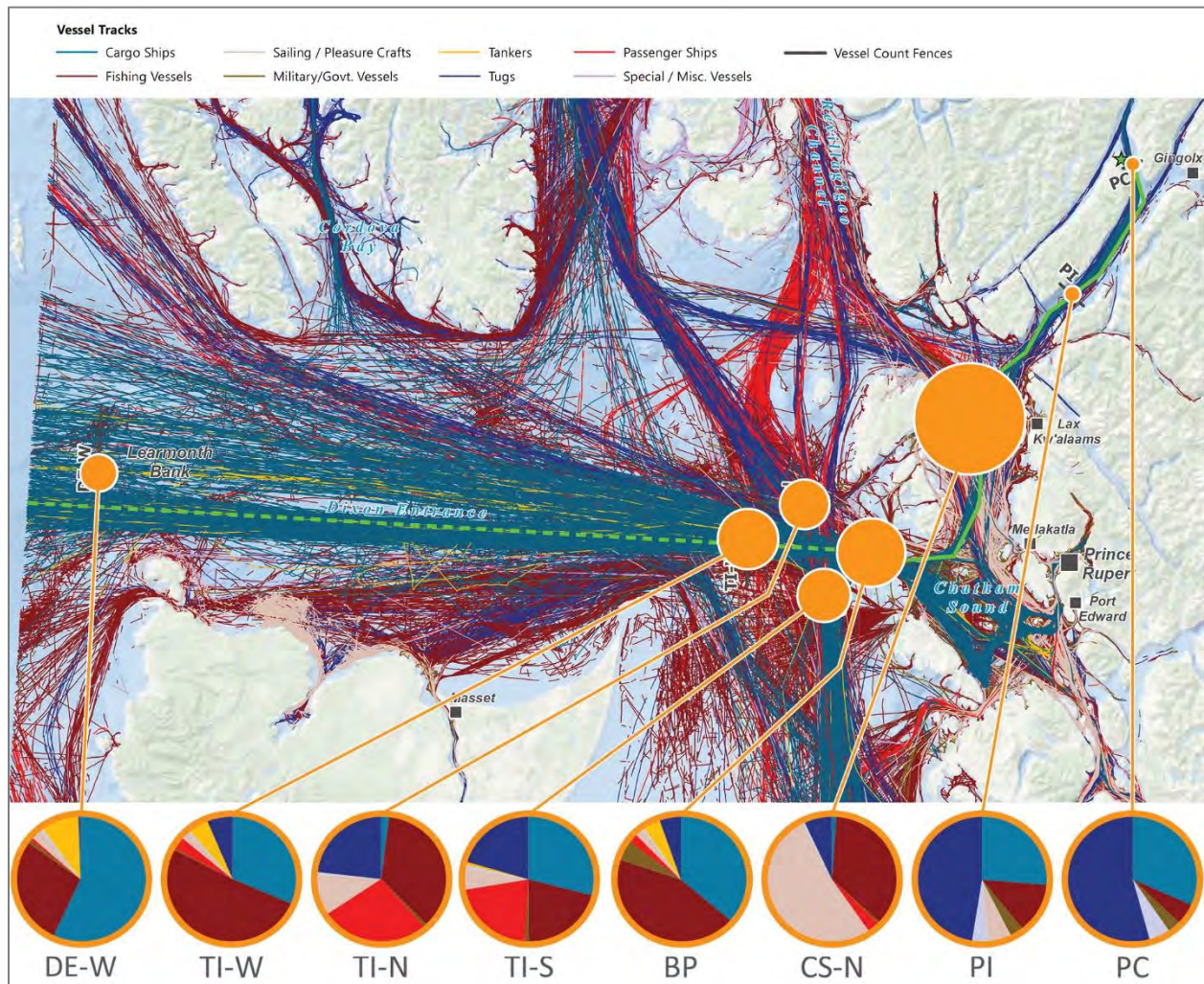

Figure 15 - Traffic by vessel type (2019 data, orange circle proportional to traffic volume)

The following observations are made with respect to annual trips:

- Fishing and sailing / pleasure craft account for most vessel traffic
- Passenger vessels (i.e., mostly cruise ships to Alaska) cross the marine route at Triple Islands (approximately 370 trips per year) and Chatham Sound (approximately 218 trips per year)
- Chatham Sound has the highest traffic relative to other parts of the selected marine route. Chatham Sound traffic is still relatively low with only 20 vessels per day passing on average
- Large vessel movements (i.e., cargo, tankers, and cruise vessels) are infrequent. Brown Passage has the highest number of large vessel trips in the region, with an average of three per day
- Traffic volume in Portland Inlet and Portland Canal is low. Most traffic is tugs and cargo vessels heading to Stewart with an average of two trips per week

2.3.3 Project Marine Traffic

The marine route from Dixon Entrance to Chatham Sound is used by vessels of similar size, and the route into Portland Inlet and Portland Canal is used by cargo ships. Forecast LNG carriers and NGL product vessel traffic will not change regional traffic routes or patterns.

The Project forecasts 140 to 160 LNG carrier calls per year and 8 to 12 NGL product vessel calls per year [10]. On average, the forecast LNG carrier traffic would represent three additional vessels per week compared to the 21 large, piloted vessels per week passing through Brown Passage.

Forecast traffic to the marine terminal is an increase relative to the average of one large, piloted vessel per week transiting Portland Inlet and Portland Canal. The forecast traffic is still small compared to other ports along the Northern Coast. The marine route through Portland Inlet and Portland Canal is like the routes to other ports along the North Coast (e.g., Kitimat), and can accommodate the forecast LNG carriers and NGL product vessels with capacity remaining.

2.4 Special Operational Areas

Mariners are advised of special operations which might affect the safety of shipping through navigational warnings (NAVWARNs) from the Canadian Coast Guard (CCG) [11]. CCG Marine Communications and Traffic Services (MCTS) centres broadcast NAVWARNs for 7 days on their continuous marine broadcast (CMB) service. NAVWARNs may be broadcast by medium frequency radiotelephone and NAVTEX.

NAVWARNs are posted on the navigational warnings website and remain in effect until cancelled or until covered by a Notice to Mariners (NOTMAR) [12].

2.4.1 Military Operations

The marine route traverses a Canadian military “sub-surface operations area” designated for submarine operations. The area, known as Dixon, is shown in Figure 16. The Dixon area extends from the Pacific Ocean through Dixon Entrance to the Port of Prince Rupert [13].

Use of military exercise areas is infrequent and does not impede shipping on the North Coast. Vessels are advised by NAVWARNs of when areas are in use by the military and any precautions to be taken. Further details and coordinates of the geographical limits of the military exercise areas are available in *Notices to Mariners Annual Edition* [13].

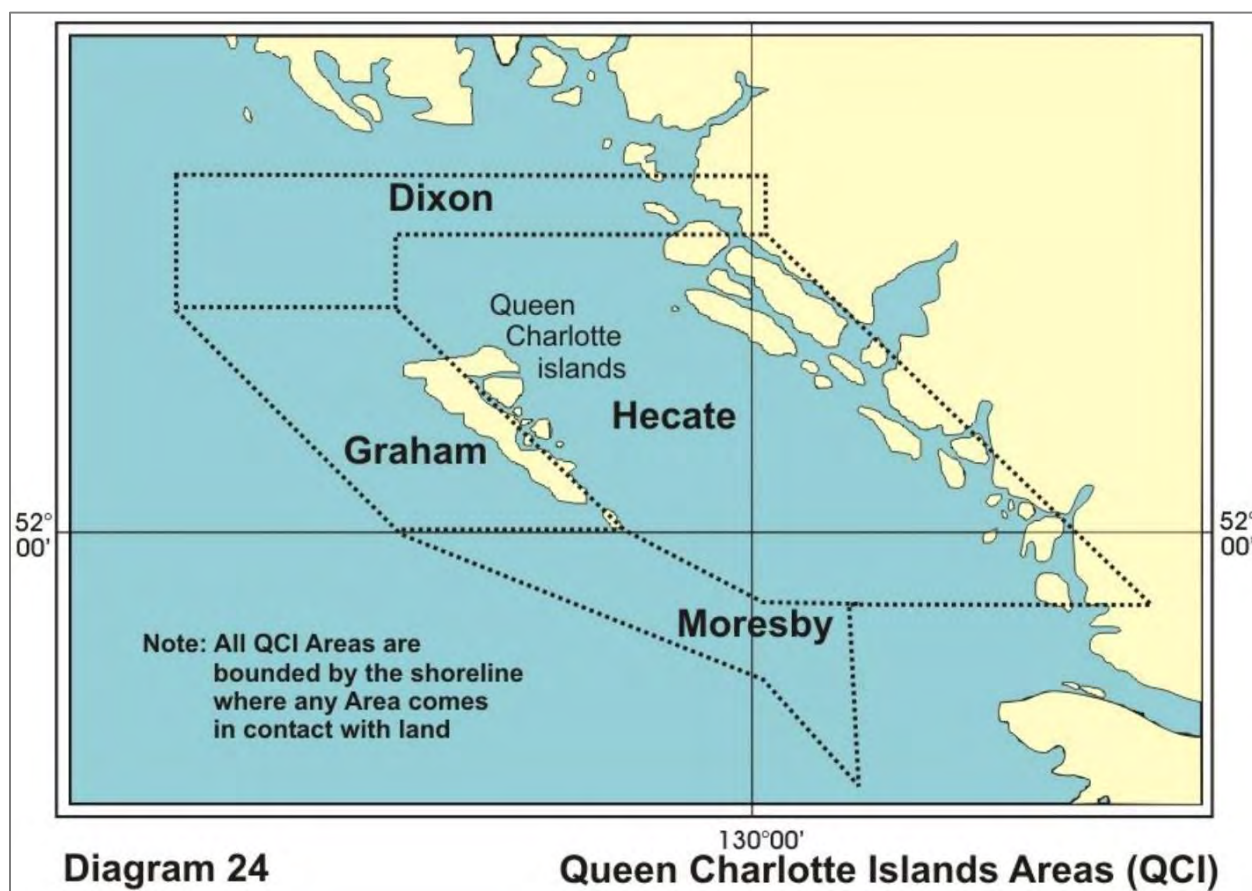

Figure 16 – Canadian military exercise areas [13]

2.4.2 Offshore Exploration and Exploitation Areas

Offshore exploration and exploitation areas could include oil and gas industry activities, aquaculture, or wind farms. Each of these is described below, with respect to the marine route.

2.4.2.1 Oil and Gas Exploration

The Government of Canada imposed a moratorium on oil and gas exploration activities in BC waters in 1972 [14]. The moratorium remains in effect with no exploration and exploitation of oil and gas reserves on Canada's west coast, including seismic survey, drilling, and recovery.

2.4.2.2 Aquaculture

There are aquaculture sites on BC's coast, typically in sheltered waters close to shore, not near the selected marine route. There are no finfish aquaculture sites near the selected marine route. There are shellfish aquaculture sites near Prince Rupert, with the closest being approximately 10 km from the marine route as shown in Figure 17.



Figure 17 – North Coast shellfish aquaculture sites [15]

2.4.2.3 Offshore Wind Farms

There are no existing wind farms or approved wind farm projects along the selected marine route.

2.4.3 Seaplane Operations

Seaplanes, or floatplanes, are frequently used to access areas of the BC coast that are otherwise inaccessible or difficult to access by road. There are no seaplane aerodromes near the marine route. The closest seaplane aerodromes include:

- Masset Harbour, Haida Gwaii – over 30 km from the marine route
- Prince Rupert – over 24 km from the marine route
- Gingolx – approximately 10 km from where the selected marine route turns into Portland Canal from Portland Inlet

LNG carriers and NGL product vessels will not affect the safe landing and takeoff of seaplanes at aerodromes in the region.

2.5 Regional Network Focal Points

Three vessel traffic focal points along the marine route are highlighted in Figure 18 and discussed in the following sections.

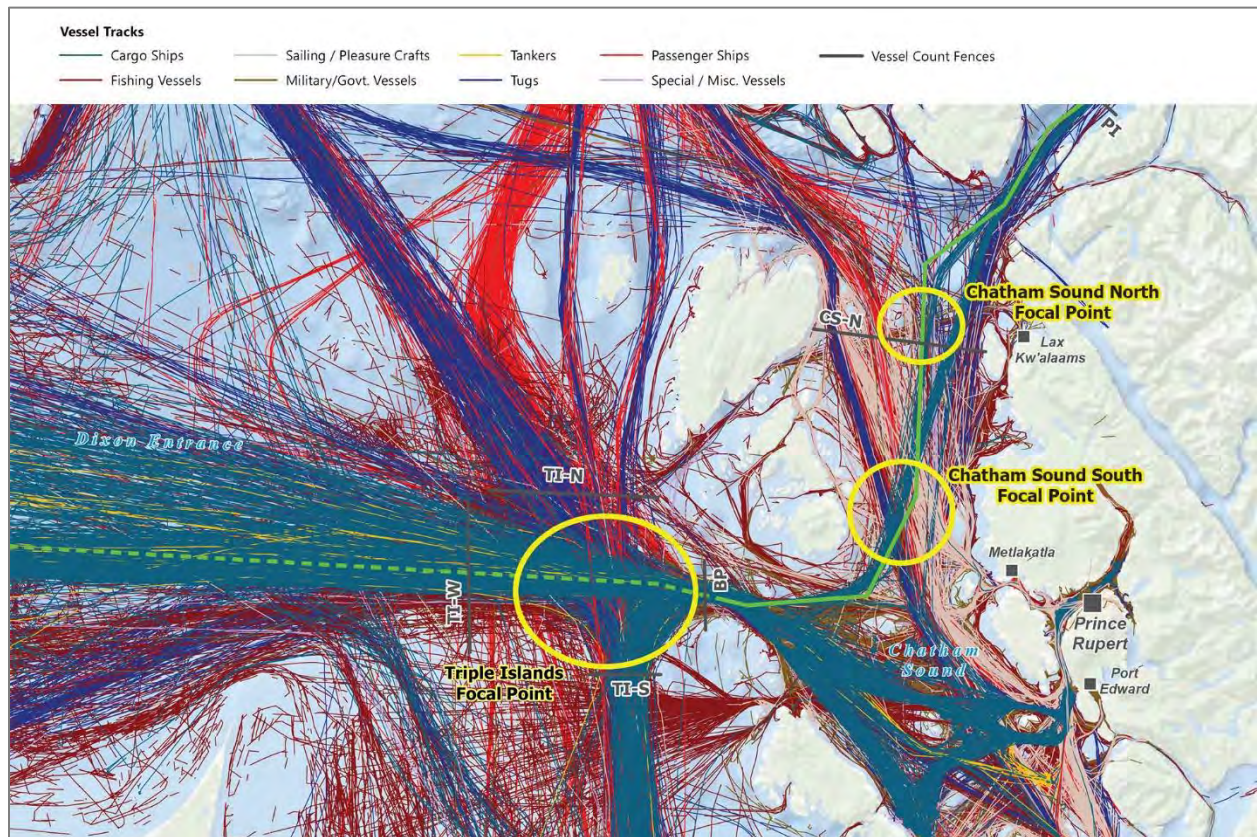

Figure 18 – Marine network focal points (2019 data)

2.5.1 Triple Islands

The area north of Triple Islands is a focal point for regional traffic, with the following vessel patterns:

- Cargo vessel and tanker traffic from the west (i.e., Prince Rupert) and the south (i.e., Hecate Strait) merge in Brown Passage. Combined cargo vessel and tanker movements through Brown Passage average 18 per week
- Tug traffic is generally in a north-south alignment. Tug movements average six per week
- Passenger vessel traffic (i.e., cruise ships) is in a north-south alignment. Calculated annually, the average number of passenger vessels passing Triple Islands is seven per week. Calculated over the summer cruise ship season, the average is closer to 28 vessels per week

Regional vessel traffic rarely moves through the Triple Islands area at the same time. When the timing of vessels coincides, there is room to pass at a safe distance.

2.5.2 Chatham Sound South

As LNG carriers and NGL product vessels turn north after Brown Passage and enter Chatham Sound, there is an intersection point with tugs and fishing and sailing / pleasure craft vessels moving north-south through Chatham Sound.

The number of tug movements in Chatham Sound is low at approximately 10 per week. The combined total of fishing and sailing / pleasure craft is an average of over 120 vessels per week. Both vessel types have large seasonal variations (see Figure 13) meaning the average traffic volume in summer could be closer to 80 vessels per day.

The traffic volumes in Chatham Sound are low relative to other parts of the BC coast and there is room for vessels to pass at a safe distance. Fishing and sailing / pleasure craft operate with greater volumes of large vessel traffic further south in Chatham Sound near Prince Rupert.

2.5.3 Chatham Sound North

The plots of yearly traffic show tracks of military / government vessels and fishing vessels travelling east-west, from Lax Kw'alaams and Inksip Passage to the Dundas Islands, intersecting the marine route. There were approximately 20 trips between Inksip Passage and Chatham Sound in all of 2019. The traffic volume is likely higher, accounting for non-AIS-equipped vessels.

The volume of crossing traffic to and from Inksip Passage is low. LNG carriers and NGL product vessels will communicate with MCTS 15 minutes prior to entering the Vessel Traffic Services (VTS) zone calling-in-point 19 (i.e., Wales Point, a line joining Wales Point to Maskelyne Point) [16]. The Project will work with applicable agencies to investigate the feasibility of added communication services along the marine route.

2.6 Fishing Activities

Regional fishing activity is assessed in this report for navigational safety. Regional fishing traffic patterns include:

- Fishing vessel movements are concentrated in Chatham Sound and near Prince Rupert
- Fishing vessel movements outside Prince Rupert and Chatham Sound are sparse and widely distributed
- Fishing vessels are not constrained to Brown Passage like larger piloted vessels. The proportion of fishing vessels not using Brown Passage is likely to be higher than shown on Figure 5, due to non-AIS vessels typically being smaller and able to use other routes

From the fishing vessel traffic patterns in Figure 5 and the volume statistics in Table 3 and Table 4, the most likely locations for interactions with fishing vessels is in Chatham Sound, and to a lesser extent, Brown Passage. Fishing and sailing / pleasure craft operate with greater volumes of large vessel traffic further south in Chatham Sound near Prince Rupert and other regions of the BC coast.

2.7 Alternative Routes

Alternative routes are considered in the *Marine Route Report* [1]. The alternative routes for traffic transiting to Portland Inlet from Dixon Entrance all pass north of Dundas Island. The vessel traffic patterns assessed in this report support the conclusion that the routes north of Dundas Island should not be used. There are no large cargo vessels using the alternative routes. Using the alternative routes would result in significant changes to regional traffic patterns and existing pilotage services.

The marine route will be further defined during subsequent stages of Project development, including full mission bridge simulation with the participation of the PPA and British Columbia Coast Pilots Ltd. (BCCP).

3 Marine Terminal Area Traffic

3.1 Traffic in Portland Canal

From the analysis of AIS data in Section 2.3, existing vessel traffic past the Project Site (Site) is infrequent. 83 vessels passed through Portland Canal in 2019, and 70 passed through in 2021. The timing and mix of vessels passing in 2019 is shown in Figure 19. Vessel traffic is primarily cargo vessels of 125 to 200 m in length, and tugs of 13 to 44 m in length heading past the marine terminal location. There is no seasonality to the traffic, with an average of six to seven vessels per month.

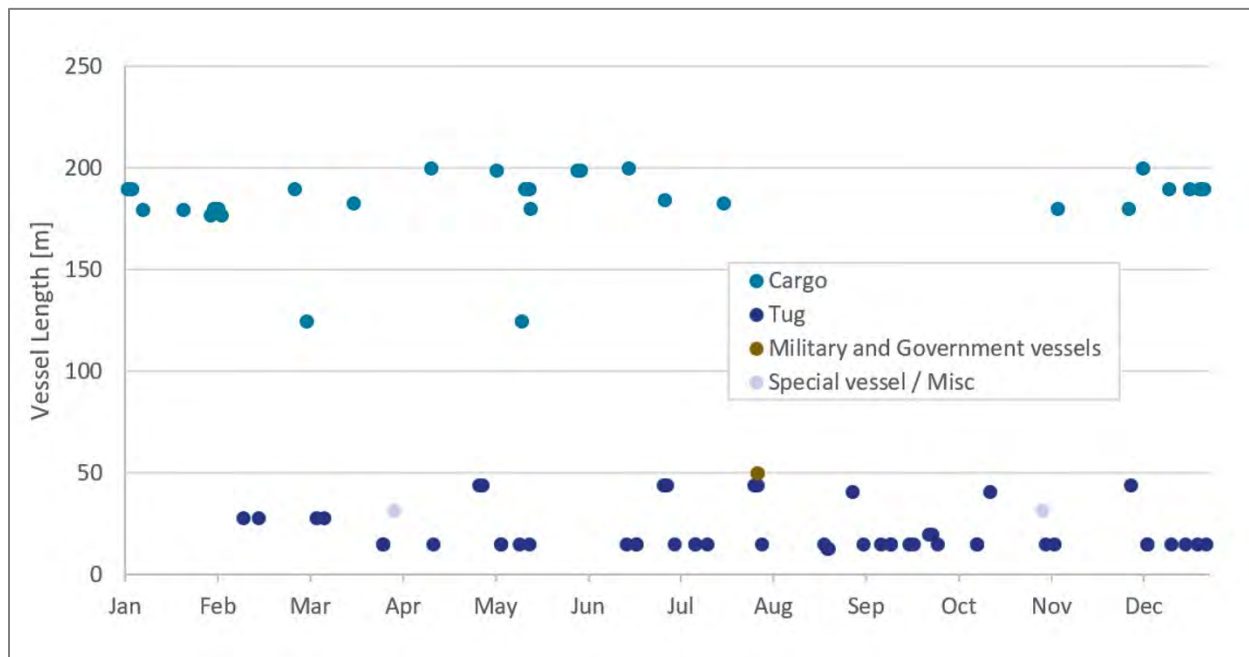

Figure 19 - Vessel traffic in Portland Canal

The vessel tracks in Portland Canal in 2019 are in Figure 20. All vessels moved past the Site using the middle of the channel, generally passing over 1 km from the marine terminal.

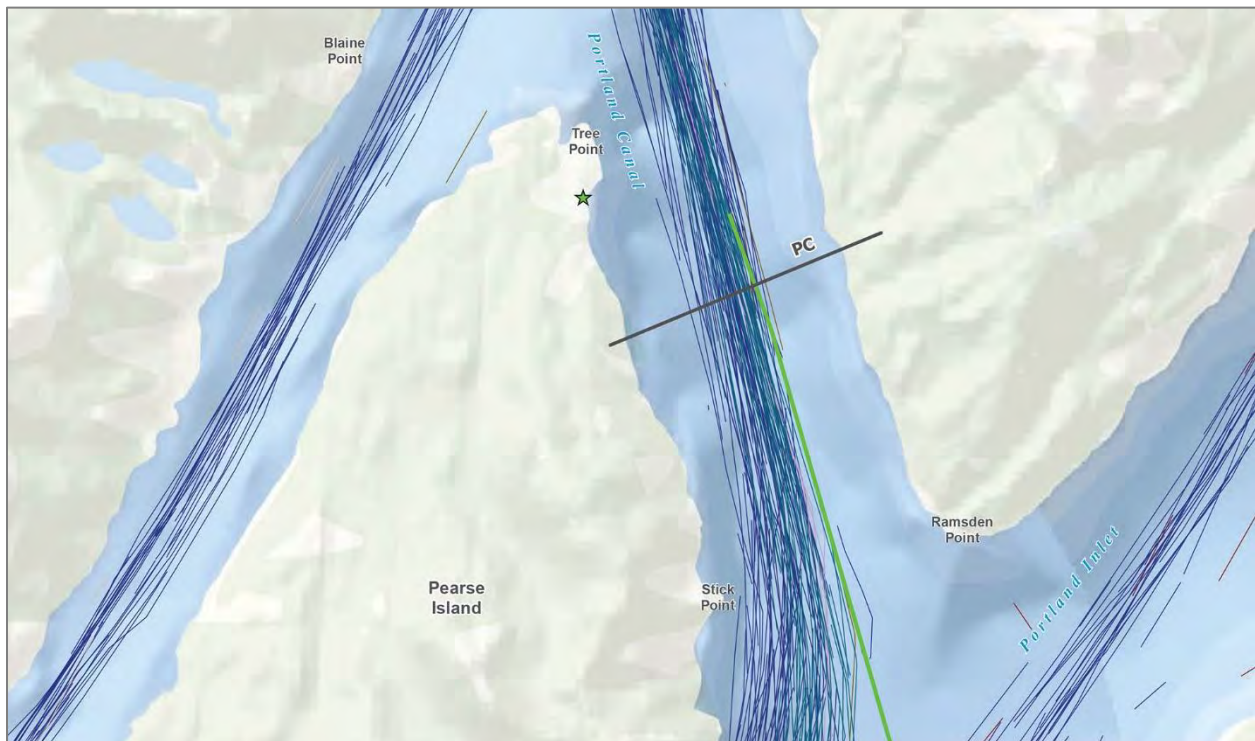

Figure 20 - Annual vessel traffic past the Site (2019 data)

3.2 Local Fishing and Recreational Activities

There are no recorded tracks of AIS-equipped fishing vessels passing the terminal in 2019, and one fishing vessel track recorded in 2021. As the ratio of non-AIS to AIS-equipped vessels is believed to be approximately 5 (see Section 2.3.2.2), more fishing vessels may have passed through Portland Canal than indicated by AIS data. Available information suggests that fishing vessel traffic near the Site is not common.

There are no recorded tracks of AIS-equipped sailing / pleasure craft in either 2019 or 2021. One “special vessel” recorded was a Canadian government research vessel. Available information suggests that non-fishing recreational use near the Site is low.

3.3 Traffic Support Services

MCTS for the region are coordinated from Prince Rupert. Regional vessel traffic support services and infrastructure are discussed in the *Marine Route Report* [1].

References

- [1] Westmar Advisors Inc., "Marine Route," 1220197_P01_22_RPT_0001, 2023.
- [2] Westmar Advisors Inc., "Vessel Specifications," 1220197-P01-24-RPT-0001, 2023.
- [3] Norma Serra-Sogas, "Small Vessel Surveys in the Northern Shelf Bioregion, British Columbia." Transport Canada, Oct. 28, 2021.
- [4] International Maritime Organization, "International Convention for the Safety of Life at Sea (SOLAS)." Accessed: Aug. 22, 2022. [Online]. Available: [https://www.imo.org/en/About/Conventions/Pages/International-Convention-for-the-Safety-of-Life-at-Sea-\(SOLAS\),-1974.aspx](https://www.imo.org/en/About/Conventions/Pages/International-Convention-for-the-Safety-of-Life-at-Sea-(SOLAS),-1974.aspx)
- [5] International Maritime Organization, "AIS transponders." Accessed: Oct. 04, 2022. [Online]. Available: <https://www.imo.org/en/OurWork/Safety/Pages/AIS.aspx>
- [6] Port of Vancouver, "Cruise returns to the Port of Vancouver, within enhanced health and safety framework." Accessed: Apr. 30, 2023. [Online]. Available: <https://www.portvancouver.com/news-and-media/news/cruise-returns-to-the-port-of-vancouver-within-enhanced-health-and-safety-framework/>
- [7] K-J Millar, "Pembina ships first vessel of LPG out of Prince Rupert," *The Northern View*, Apr. 12, 2021. Accessed: Aug. 15, 2022. [Online]. Available: <https://www.thenorthernview.com/news/pembina-ships-first-vessel-of-lpg-out-of-prince-rupert/>
- [8] Canada Border Services Agency, "Travel Advisory: REMINDER – On August 9th, new public health measures will come into force affecting travel to Canada." Accessed: Apr. 30, 2023. [Online]. Available: <https://www.canada.ca/en/border-services-agency/news/2021/08/travel-advisory-reminder--on-august-9th-new-public-health-measures-will-come-into-force-affecting-travel-to-canada.html>
- [9] Denise Wong and Monika Gul, "Demand for boats in B.C. so high, dealers running out," *CityNews Vancouver*. Accessed: Apr. 30, 2023. [Online]. Available: <https://vancouver.citynews.ca/2021/05/19/bc-boat-demand/>
- [10] Ksi Lisims LNG, "Ksi Lisims LNG Detailed Project Description," BC Environmental Assessment Office, 2022, p. 680. Accessed: Aug. 15, 2022. [Online]. Available: <https://www.projects.eao.gov.bc.ca/p/60edc23bc69c5e0023a12539/project-details>
- [11] Canadian Coast Guard, "Radio Aids to Marine Navigation 2023." 2023.
- [12] Canadian Coast Guard, "Navigational and NAVAREA warnings." Accessed: Aug. 04, 2023. [Online]. Available: <https://www.ccg-gcc.gc.ca/mcts-sctm/navwarn-avnav-ca-eng.html>
- [13] Canadian Coast Guard, "Notices to Mariners 1 to 46, Annual Edition 2023." Canadian Coast Guard. Accessed: Aug. 05, 2023. [Online]. Available: https://publications.gc.ca/collections/collection_2023/mpo-dfo/Fs151-4-2023-eng.pdf
- [14] Al Hudec and Van Penick, "British Columbia Offshore Oil and Gas Law," *Alberta Law Review*, vol. 41, no. 1, p. 101, 2003.
- [15] Department of Fisheries and Oceans, "Aquaculture maps | Pacific Region." Accessed: Oct. 06, 2022. [Online]. Available: <https://www.dfo-mpo.gc.ca/aquaculture/bc-cb/maps-cartes-eng.html>
- [16] C. C. G. Government of Canada, "Radio Aids to Marine Navigation 2023 Part 3: Vessel Traffic Services." Accessed: Oct. 02, 2023. [Online]. Available: <https://www.ccg-gcc.gc.ca/publications/mcts-sctm/ramn-armn/part3-eng.html>

1 **ATTACHMENT E.2 MARINE ROUTE**

Ksi Lisims LNG
Navigation Safety Assessment

Marine Route

11 October 2023



Disclaimer

This report is not intended to stand alone without reference to the instructions given to Westmar by Ksi Lisims LNG, communications between Westmar and Ksi Lisims LNG, and any other reports, proposals or documents prepared by Westmar for Ksi Lisims LNG under the governing contract between Westmar and Ksi Lisims LNG. To understand the suggestions, recommendations and opinions expressed herein, reference must be made to all relevant documents and communications.

This report has been prepared only for the purposes that are set out in the governing contract between Westmar and Ksi Lisims LNG. The findings, recommendations, suggestions and or opinions expressed in this report are only applicable to the purposes for which the report is expressly provided, and then only to the extent that there has been no material alteration to or variation from the information provided or available to Westmar.

The information and opinions expressed in this report are for the sole use and benefit of Ksi Lisims LNG. No other party may use or rely upon the report or any portion thereof without Westmar's prior written consent, and such use shall be on terms and conditions as Westmar expressly approves. Ownership in and copyright for the contents of the report belong to Westmar. Any use which a third party makes of the report is the sole risk and responsibility of such third party. Westmar accepts no responsibility whatsoever for loss or damages suffered by any third party in relation to use of this report.

Company Details

Westmar Advisors Inc.
700 - 1901 Rosser Avenue
Burnaby, BC, V5C 6R6

T 604 770 4787

info@westmaradvisors.com

Table Contents

Abbreviations	vii
Preface	xii
1 Introduction	1
1.1 Project Background	1
2 Alternative Marine Routes	3
2.1 Route A - Triple Island Pilot Boarding Station	4
2.2 Marine Route B - Caamaño Passage	4
2.3 Marine Route C – North of Dundas Island	4
2.4 Marine Route Selection	5
3 Marine Route	6
3.1 Coastal Communities	7
3.2 Open Ocean to Triple Islands	9
3.3 Triple Islands to Chatham Sound	10
3.3.1 Brown Passage	10
3.3.2 Chatham Sound	12
3.3.3 Main Passage	12
3.4 Portland Inlet to Portland Canal	12
3.4.1 Portland Inlet	13
3.4.2 Portland Canal	13
3.5 Transit Speeds	13
3.6 Topography	14
4 Metocean Conditions	15
4.1 Precipitation and Visibility	15
4.2 Temperature and Icing	16
4.3 Storm Events	16
4.4 Wind	16
4.5 Waves	18
4.6 Vessel Wake	19
4.7 Tides and Currents	19
4.8 Summary	21
5 Compulsory Pilotage Areas	22
5.1 Triple Island Pilot Boarding Station	22
5.2 Helicopter Pilot Boarding	23
5.3 Pilot Demand	23
6 Navigation and Vessel Traffic Services	25

6.1	Navigational Aids	25
6.1.1	Existing Lights, Buoys and Fog Signals	25
6.1.2	Radar Beacons	25
6.1.3	Improvements to Aids to Navigation	26
6.1.4	Virtual Aids to Navigation	26
6.2	Navigational Charts	26
6.3	Regional Radio Communications Infrastructure	27
6.3.1	Marine Communications and Traffic Services	27
6.3.2	Pre-Arrival Information Reports	29
6.3.3	Advanced Reporting Requirements	29
6.3.4	Entering a VTS Zone and Call-In Points	29
6.3.5	Global Maritime Distress and Safety System in Canada	30
6.4	Weather Forecasts	32
7	Tug Specifications	33
8	Vessel Underkeel Clearance	34
9	Anchorage	35
9.1	Dixon Entrance	35
9.2	Chatham Sound	38
9.3	Portland Inlet	38
9.4	Port of Prince Rupert	39
9.5	Other Anchorages	39
9.6	Holding Areas	40
10	Desktop Simulation	41
10.1	Simulation Objectives	41
10.2	Methodology	41
10.3	Findings and Recommendations	41
	References	43
A	Desktop Navigation Simulation Study	Error! Bookmark not defined.
B	Existing Lights, Buoys and Fog Signals	49

Appendices

- Appendix A Desktop Navigation Simulation Study
- Appendix B Existing Lights, Buoys and Fog Signals

List of Tables

Table 1 - Project parameters	1
------------------------------	---

Table 2 - Marine route waypoints.....	7
Table 3 – Triple Islands fog observations	15
Table 4 - Maximum wind speeds at Prince Rupert [17]	16
Table 5 - Wind speed return intervals at Holland Rock [19]	17
Table 6 - Extreme wind speed estimated using Grey Islet records (1994-2022) [20].....	18
Table 7 - Simulated extreme wave parameters at the Site (424718 E, 6097852 N) [20].....	19
Table 8 - Prince Rupert tidal levels.....	19
Table 9 - Forecast tidal levels at Gingolx	20
Table 10 - Current speed (cm/s) near the Site [20].....	20
Table 11 - CHS Charts applicable to the marine route.....	27
Table 12 - Calling-in points along the marine route [45].....	30
Table 13 - Dixon Entrance anchorages or possible places of refuge	36

List of Figures

Figure 1 – Alternate marine routes.....	3
Figure 2 - Overview of the selected marine route (Canadian Hydrographic Service Chart 3002, depths are in fathoms and feet).....	6
Figure 3 - Coastal communities along the marine route.....	8
Figure 4 – Marine route from open ocean to the Triple Island pilot boarding station (Canadian Hydrographic Service Chart 3002, depths in fathoms and feet to chart datum).....	9
Figure 5 – Marine route from the Triple Island pilot boarding station to Chatham Sound (CHS Chart 3800, depths in metres to chart datum).....	10
Figure 6 - Northern and southern routes through Brown Passage [11]	11
Figure 7 - Marine route from Brown Passage to Main Passage (CHS Chart 3002, depths in fathoms and feet to chart datum)	12
Figure 8 – Marine route from Portland Inlet to Portland Canal (CHS Chart 3002, depths in fathoms and feet to chart datum)	13
Figure 9 – Aids to Navigation along the north coast of Haida Gwaii.....	14
Figure 10 - Wind Rose for Grey Islet, 1994-2022 (left); and Wil Milit, 2021-2022 (right) [20].....	18
Figure 11 - Compulsory Pilotage Areas (CHS Chart 3002, depths in fathoms and feet to chart datum).....	22
Figure 12 - Triple Island pilot boarding station (CHS Chart 3800, depths in metres to chart datum)	23
Figure 13 - MCTS centres and remote controlled sites [37].....	28
Figure 14 - Vessel Traffic Services - Prince Rupert North - Sector 2, extents and calling-in points [45]	29
Figure 15 - Digby Island NAVTEX transmitter range [45].....	31
Figure 16 - North Coast marine forecast areas, observation sites and radio network [52].....	32
Figure 17 - Dixon Entrance anchorages or possible places of refuge.....	35

Figure 18 – Chatham Sound emergency anchorage areas (CHS Chart 3800, depths in metres to chart datum)..... 38

Figure 19 - Port Simpson anchorages or possible places of refuge (CHS Chart 3959, depths in metres to chart datum)..... 39

Abbreviations

Abbreviation	Description
°C	degrees Celsius
ABS	American Bureau of Shipping
ADCP	acoustic doppler current profiler
AIS	automatic identification system
AIS ATON	automatic identification system aid to navigation
AK	Alaska
ANSI	American National Standards Institute
ARI	average recurrence interval
ATON	aids to navigation
BC	British Columbia
BCCP	British Columbia Coast Pilots Ltd.
BCER	BC Energy Regulator
BNWAS	bridge navigational watch alarm system
BOG	boil off gas
BV	Bureau Veritas
CCG	Canadian Coast Guard
CHS	Canadian Hydrographic Services
CMB	continuous marine broadcast
CPAs	Compulsory Pilotage Areas
DAS	docking assist system
deg	degree
DFO	Fisheries and Oceans Canada
DNV	Det Norske Veritas
dwt	deadweight tonnage
EA	environmental assessment
ECCC	Environment and Climate Change Canada
ECDIS	electronic chart display and information system
EDG	emergency diesel generators
EEBD	Emergency Escape Breathing Device
EMSA	enhanced maritime situation awareness
ENC	electronic navigational chart
EOC	Emergency Operations Centre
EPIRB	emergency position-indicating radio beacon
ERS	emergency release system

Abbreviation	Description
ESD	emergency shut down
ETA	estimated time of arrival
EU	environmental unit
FEED	front-end engineering design
FFA	fire fighting appliances
FLNG	floating liquefaction, storage, and off-loading barge
FMBS	full mission bridge simulation
FMO	Federal Monitoring Officer
FSA	Formal Safety Assessment
FSRU	floating storage and regassification units
GMDSS	Global Maritime Distress, and Safety System
GNSS	Global Navigation Satellite System
GTT	Gaztransport and Technigaz
HFO	heavy fuel oil
HNS	hazardous and noxious substances
Hs	significant wave height
IACS	International Association of Classification Societies
IALA	International Association of Marine Aids to Navigation and Lighthouse Authorities
ICS	Incident Command System
IGC Code	<i>International Code for the Construction and Equipment of Ships Carrying Liquefied Gases in Bulk</i>
ILO	International Labour Organization
IMO	International Maritime Organization
ISGOTT	<i>International Safety Guide for Oil Tankers and Terminals</i>
ISM	International Safety Management
ISPS	<i>International Ship and Port Facility Security Code</i>
kHz	kilohertz
km	kilometre
kn	knot
LBP	length between perpendiculars
LFL	lower flammability limit
LLWLT	lower, low water, large tide
LNG	liquefied natural gas
LOA	length overall
LOS	level of service
LPG	liquefied petroleum gas
LR	Lloyd's Register

Abbreviation	Description
LSA	life-saving appliances
LSIR	location specific individual risk
LTA	line throwing appliance
m	metre
m	metres per second
m ²	square metres
m ³	cubic metres
m ³	cubic metres
m ³ / hour	cubic metres per hour
MARPOL	<i>International Convention for the Prevention of Pollution of Ships</i>
MCTS	Marine Communications and Traffic Services
MDO	marine diesel oil
MGO	marine gas oil
MOF	material off-loading facility
MOU	Memorandum of Understanding
MSI	Marine Safety Inspectors
MSOC	Marine Security Operations Centre
MTBE	methyl tertiary butyl ether
mtpa	million tonnes per annum
NASP	National Surveillance Aerial Program
NAVTEX	Narrow Band Direct Printing Telegraphy
NAVWARN	navigational warnings
NGL	natural gas liquid
NK	Nippon Kaiji Kyokai
NLG	Nisga'a Lisims Government
NLS	Noxious Liquid Substances
NOA	notice of arrival
North Coast	north coast of British Columbia
NOTMAR	Notices to Mariners
NRA	BCCP / PPA Navigational Risk Assessment
NSA	navigation safety assessment
NW	northwest
OCIMF	Oil Companies International Marine Forum
ODAS	ocean data acquisition system
OGAA	<i>Oil and Gas Activities Act</i>
OPP	Oceans Protection Plan

Abbreviation	Description
OPRC	<i>International Convention on Oil Pollution Preparedness, Response and Co-operation</i>
OSC	On-Scene Commander
P&I	protection and indemnity (insurance)
P&I	protection and indemnity
PAH	polycyclic aromatic hydrocarbons
PAIR	Pre-Arrival Information Reports
PIANC	World Association for Waterborne Transport Infrastructure
PMS	planned maintenance system
PORCP	National Places of Refuge Contingency Plan
PPA	Pacific Pilotage Authority
PPO	Pollution Prevention Officer
PPU	portable pilot units
PRPA	Prince Rupert Port Authority
PRPRCP	<i>Pacific Region Places of Refuge Contingency Plan</i>
PSC	Port State Control
QCDC	quick connect disconnect couplers
QRA	quantitative risk assessment
QRH	quick release hooks
QSCS	Quality System Certification Scheme
racon	radar beacon
RNC	raster navigational chart
RO	recognized organization (with respect to flag state affairs)
RO	response organization (with respect to spill response)
RT	radiotelephony
s	seconds
SAR	search and rescue
SIGTTO	Society of International Gas Tanker and Terminal Operators
SIRE	Ship Inspection Report Programme
SMPEP	Shipboard Marine Pollution Emergency Plan
SOLAS	<i>International Convention for the Safety of Life at Sea (SOLAS), 1974</i>
SOPEP	Shipboard Oil Pollution Emergency Plan
SOPF	Ship-source Oil Pollution Fund
SSL	ship-shore link
STCW	<i>International Convention on Training, Certification, and Watchkeeping for Seafarers</i>
SW	southwest
SWL	safe working load

Abbreviation	Description
t	metric tonne (equal to 1,000 kilograms)
TCMSS	Transport Canada Marine Safety and Security
TERMPOL	Technical Review Process of Marine Terminal Systems and Transshipment Sites
TOM	Terminal Operations Manual
Tp	peak wave period
TSB	Transportation Safety Board of Canada
UKC	underkeel clearance
US	United States
V-ATON	virtual aid to navigation
VDR	voyage data recorder
VHF	very high frequency
VLSFO	very low sulphur fuel oil
VTS	Vessel Traffic Services
WCMRC	Western Canada Marine Response Corporation

Preface

A Navigation Safety Assessment (NSA) is part of the Application. The NSA is an opportunity to review the Ksi Lisims LNG Project and determine whether additional resources (e.g., pilots), controls or infrastructure (e.g., navigational aids) are required and when they need to be in place. The NSA studies make-up Appendix E and findings inform Section 9 Malfunctions and Accidents and other sections (e.g., Section 7.11 Marine Use). Section 9.1.2 Planning provides a list and high-level description of the NSA studies. Additional navigation simulations will be completed before the start of operations and will be the subject of approval conditions.

1 Introduction

The Nisga'a Nation, Rockies LNG Limited Partnership (Rockies LNG) and Western LNG LLC (via its subsidiary, Western LNG ULC) (each a Proponent and collectively referred to herein as the Proponents), are proposing to jointly develop the Ksi Lisims LNG -- Natural Gas Liquefaction and Marine Terminal Project (the Project). The Project is a floating natural gas liquefaction facility and marine terminal at Wil Milit on the North Coast at the northern end of Pearse Island. The Project Site (Site) is approximately 15 km west of the Nisga'a community of Gingolx (see Figure 3) roughly centred at 55°01'26"N and 130°10'49"W.

Liquefied natural gas (LNG) carriers and natural gas liquid (NGL) product vessels will use a marine route from Dixon Entrance to Portland Canal to reach the marine terminal. The objective of the *Marine Route Report* is to assess the safety of the selected marine route for the design LNG carriers and NGL product vessels (i.e., the design vessels) described in the *Vessel Specifications Report* [1].

This report discusses the selection of the marine route and why alternate routes are not considered for normal operations. The selected marine route has also been assessed in a desktop navigation simulation study (see Appendix A). An overview of the desktop navigation simulation study scope and findings is in Section 10. Further full mission bridge simulations (FMBS) will be completed during detailed project planning and the joint British Columbia Coast Pilots Ltd. (BCCP) / Pacific Pilotage Authority (PPA) Navigational Risk Assessment (NRA).

All depths described in this report are to chart datum, unless noted otherwise. On most Canadian coastal charts, the surface of lower low water, large tide (i.e., LLWLT) has been adopted as chart datum [2]. All charts shown are copyright the Canadian Hydrographic Service.

1.1 Project Background

Project parameters, relevant to the NSA and the assessment of the selected marine route are in Table 1.

Table 1 - Project parameters

Project Parameter	Description
Marine terminal location	Wil Milit, Pearse Island, BC, Canada
Forecast annual throughput	12 million tonnes per annum (mtpa) of LNG
Gas processing capacity	Approximately 575 to 695 billion cubic feet per year (Bcf / year)
Product storage	2 permanently installed floating LNG production and storage barges (FLNG) units
Aggregate FLNG storage capacity	Approximately 490,000 cubic metres (m ³) of LNG
Minimum design LNG carrier	Approximately 140,000 m ³
Largest expected design LNG carrier	Approximately 180,000 m ³
Design LNG carrier allowance	The LNG facility design accommodates LNG carriers with capacity to 217,000 m ³

Project Parameter	Description
LNG carrier annual visits	140 to 160 LNG carriers, depending on the size of the LNG carriers used and the total LNG produced by the Project
Minimum design NGL product vessel	20,000 deadweight tonnage (dwt)
Maximum design NGL product vessel	55,000 dwt
NGL product vessel annual visits	8 to 12
NGL parcel sizes	5,000 to 30,000 m ³

Parameters for the design LNG carriers and NGL product vessels are in the *Vessel Specification Report* [1]. Design LNG carriers range from approximately 140,000 m³ to of 217,000 m³ capacity. LNG carriers calling at the marine terminal are not forecast to exceed approximately 180,000 m³ capacity. The LNG facility is being designed for LNG carriers up to 217,000 m³ capacity as a future provision. Design NGL product vessels range from approximately 5,000 to 30,000 dwt capacity.

The design LNG carriers are similar in size to ships calling at the Port of Prince Rupert. On September 21, 2022, the MSC Auriga became the largest container vessel to berth at the Port of Prince Rupert [3]. A comparison of the MSC Auriga to the design LNG carriers is provided in Table 1 in the *Vessel Specifications Report* [1]. The design LNG carriers are smaller than the maximum size design LNG carriers of up to 265,000 m³ capacity proposed for other marine terminals in BC [4].

2 Alternative Marine Routes

Three routes from Dixon Entrance to Portland Inlet have been assessed by past projects [5], including:

- A) Dixon Entrance to the Triple Island pilot boarding station, through Brown Passage, to Chatham Sound, Main Passage, Portland Inlet and Portland Canal. This route is used by piloted vessels calling at Stewart, BC.
- B) Dixon Entrance to Caamaño Passage, to the north end of Main Passage, to Portland Inlet, and Portland Canal.
- C) Dixon Entrance, north to between Celestial Reef and west Devil Rock, to north of McCulloch Rock, to south of East Devil Rock and north of Dundas Island, to the north end of Main Passage, to Portland Inlet and Portland Canal.

The three routes are shown in Figure 1.

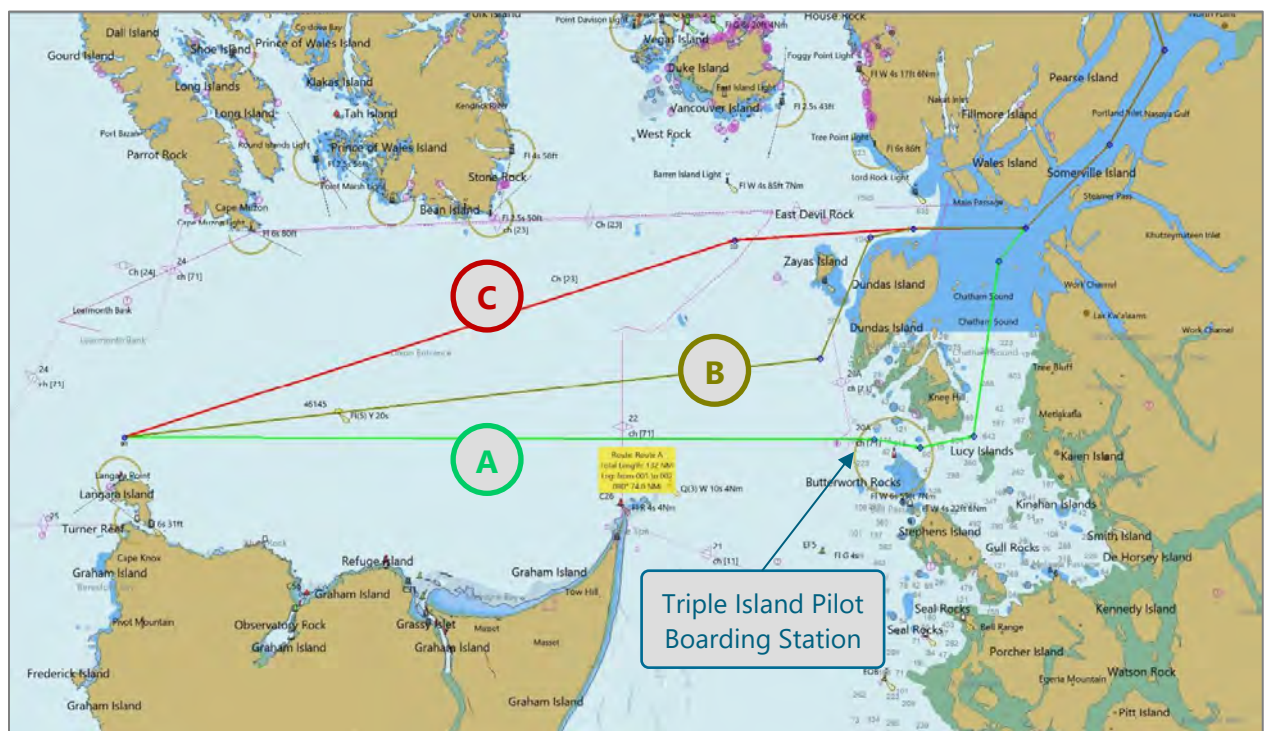

Figure 1 – Alternate marine routes

All three marine routes were assessed in the early 1980's as part of a TERMPOL Review for the Western LNG Project proposed by Dome Petroleum Limited [5]. Based on the work completed in the 1980's and recent discussions with Transport Canada, the PPA and the BCCP, the following assessment of the three alternative routes is made.

2.1 Route A - Triple Island Pilot Boarding Station

Route A is used by piloted vessels calling at Stewart, BC. The benefits of Route A include:

- The BCCP and other marine operators are familiar with Route A
- Hazards are marked with aids to navigation (ATON)
- Chatham Sound has more favourable metocean conditions for tug operations compared to the more exposed marine routes west of Dundas Island
- Triple Island pilot boarding station can be accessed from Prince Rupert by pilot boat
- Records demonstrate Route A can be used year round with minimal downtime
- Route A has been surveyed to modern standards

For Route A, the traffic density near the Triple Island pilot boarding station requires navigational awareness. Brown Passage is the most constrained portion of Route A but otherwise has deep and wide channels, suitable LNG carriers and two-way traffic.

2.2 Marine Route B - Caamaño Passage

Route B is navigable by the design vessels and is not constrained by channel width or depth. Route B is approximately the same distance as Route A. The benefits of Route B include:

- Traffic near the Triple Island pilot boarding station and in Chatham Sound is avoided
- Navigation hazards near Triple Islands are avoided

Challenges with Route B include:

- Project design vessels would need to transit to 5 nm west of Triple Island pilot boarding station to pick up a pilot, eliminating any distance or time savings compared to Route A
- The PPA has no plans to move the pilot boarding station west and the pilot boat from Prince Rupert needs to remain a viable option for pilot boarding
- Caamaño Passage is not regularly transited by piloted vessels. The PPA and BCCP require a risk assessment before Route B is used regularly
- Other agencies (e.g., Transport Canada, Environment and Climate Change Canada and or Fisheries and Oceans Canada) may require assessments regarding increased traffic through Caamaño Passage
- Route B passes through the Lax Kwaxl / Dundas and Melville Islands Conservancy
- Unmarked drying ledges extend 0.3 mile from Zayas Island and shoal rocks are up to 0.7 mile off Dundas Island into Caamaño Passage. These ledges are not marked with ATON
- Work in the 1980's recommended further improvements to ATON at Celestial Reef and Zayas Island before Caamaño Passage was used regularly (an aid to navigation at Celestial Reef was deemed technically challenging at the time)
- Caamaño Passage is subject to large swells and the portion of Route B from Triple Islands pilot boarding north to Caamaño Passage is exposed to the weather in Dixon Entrance

2.3 Marine Route C – North of Dundas Island

Route C is also navigable by the design vessels and is shorter than Route B and Route A. Route C has no other significant benefits. The challenges with Route C include:

- Navigation past unmarked navigation hazards including Celestial Reef, West Devil Rock, McCulloch Rock, and East Devil Rock is required

- Pilot boarding would be by helicopter only given boarding by boat from Prince Rupert would not be practicable (this limitation is not aligned with existing pilot operations)
- Pilot boarding would be near the above unmarked navigation hazards
- Improvements to ATON would be required
- Route C parallels the border between the US and Canada and the US regards sections of Route C being in US territorial waters

2.4 Marine Route Selection

Route A is selected for use by the design vessels. In the unlikely event that Route A is not available, delays will be managed through the timing of departure from the marine terminal, arrival at the pilot boarding station, or modifying transit speed. Under a pilot's advice, a vessel may use alternative marine routes in situations that warrant their use. Using alternate routes is not forecast under normal operations.

The selected marine route has deep and wide channels, suitable for two-way traffic. The channel widths throughout the selected marine route are wider than the recommended minimum two-way channel width calculated under industry guidelines. The most constrained portion of the route, for width and depth, is Brown Passage, used by vessels larger than the design vessels.

The selected marine route north from Chatham Sound to Portland Canal is regularly used by commercial vessels transiting to Stewart BC. Past studies determined that Chatham Sound can accommodate additional traffic, including LNG carriers [6]. The Project will result in an increase in vessel traffic and vessel size in Portland Inlet and Portland Canal. Portland Inlet and Portland Canal are deep, wide, and free of navigation hazards and can be safely transited by the largest design LNG carrier.

A review of the existing ATON shows Dixon Entrance and Chatham Sound are well supported by ATON. ATON in Portland Inlet and Portland Canal will be reviewed as part of ongoing CCG level of service (LOS) reviews and during the NRA. ATON at the marine terminal will be specified during detailed planning, with input from the FMBS and NRA. Further discussion of navigational hazards and risk mitigation measures is in the *Casualty Data and Risk Analysis Report* [7].

3 Marine Route

The selected marine route is from Dixon Entrance to Triple Island pilot boarding station, through Brown Passage, to Chatham Sound, Main Passage, Portland Inlet and Portland Canal, ending at Wil Milit on Pearse Island (see Figure 2). For this report the selected marine route has been divided into three sections:

- 1) **Open ocean to the Triple Island pilot boarding station** – From open ocean (i.e., Canada’s territorial 12 nm limit), east through Dixon Entrance, south of Learmonth Bank and north of Haida Gwaii, to Triple Island pilot boarding station
- 2) **Triple Island pilot boarding station to Portland Inlet** – From the Triple Island pilot boarding station, through Brown Passage, north into Chatham Sound, passing north of Lucy Islands, north through Main Passage to the entrance of Portland Inlet
- 3) **Portland Inlet to Portland Canal** - Northeast along Portland Inlet, turning north into Portland Canal and the marine terminal at the north end of Pearse Island

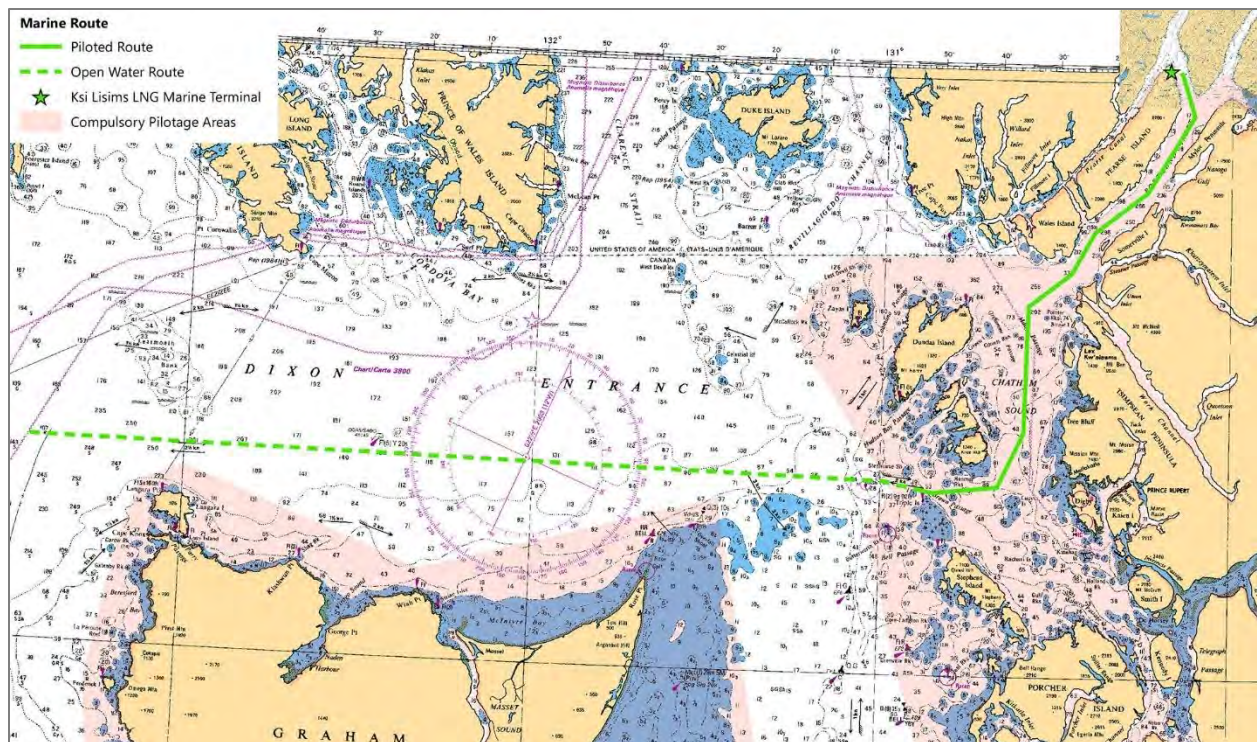

Figure 2 - Overview of the selected marine route (Canadian Hydrographic Service Chart 3002, depths are in fathoms and feet)

Arriving and departing LNG carriers and NGL product vessels will transit the same marine route. LNG carriers will arrive in ballast and depart fully laden, while NGL product vessels may arrive in ballast or partially laden and will depart partially or fully laden. All LNG carriers arriving at the marine terminal will carry a small amount of product, or heel, used to keep the cargo tanks cool. No “warm” LNG carriers may call at the marine terminal.

Project LNG carriers and NGL product vessels will travel through the centre of the channels unless there is a navigational safety reason not to. LNG carriers and NGL product vessels will not use alternative routes during normal operations. As with all shipping, it is the master’s responsibility, with the pilot’s assistance, to select the safest route for the prevailing conditions.

Waypoints for the selected marine route are in Table 2. Waypoints and segments are numbered west to east along the route. The route will be further defined during detailed project planning and the NRA with the participation of the PPA and BCCP.

Table 2 - Marine route waypoints

Waypoint ID	Latitude	Longitude	Length [km]	Heading
0	N54° 20.573'	W133° 26.811'	NA	NA
1	N54° 19.542'	W130° 59.646'	158.2	328° 24' 28"
2	N54° 18.480'	W130° 51.100'	9.4	318° 00' 27"
3	N54° 18.785'	W130° 46.135'	5.4	336° 24' 31"
4	N54° 19.170'	W130° 39.879'	6.8	336° 29' 54"
5	N54° 24.651'	W130° 35.501'	11.3	35° 50' 54"
6	N54° 37.419'	W130° 35.119'	23.9	59° 31' 19"
7	N54° 40.747'	W130° 27.772'	10.0	9° 03' 53"
8	N54° 44.964'	W130° 23.735'	9.0	32° 05' 15"
9	N54° 49.046'	W130° 14.694'	12.3	9° 15' 04"
10	N54° 56.767'	W130° 6.647'	16.8	30° 20' 00"
11	N55° 0.466'	W130° 8.614'	7.2	77° 35' 07"

3.1 Coastal Communities

Communities accessible from the marine route are shown in Figure 3. Communities and their approximate distance to the closest point of the marine route include:

- Village of Masset, Haida Gwaii – 30.0 km
- City of Prince Rupert and District of Port Edward – 20.0 km
- Lax Kw'alaams – 9.5 km
- Village of Gingolx – 10.5 km
- Metlakatla – 12.0 km



Figure 3 - Coastal communities along the marine route

3.2 Open Ocean to Triple Islands

The segment of the marine route from open ocean to the Triple Island pilot boarding station through Dixon Entrance is in Figure 4.

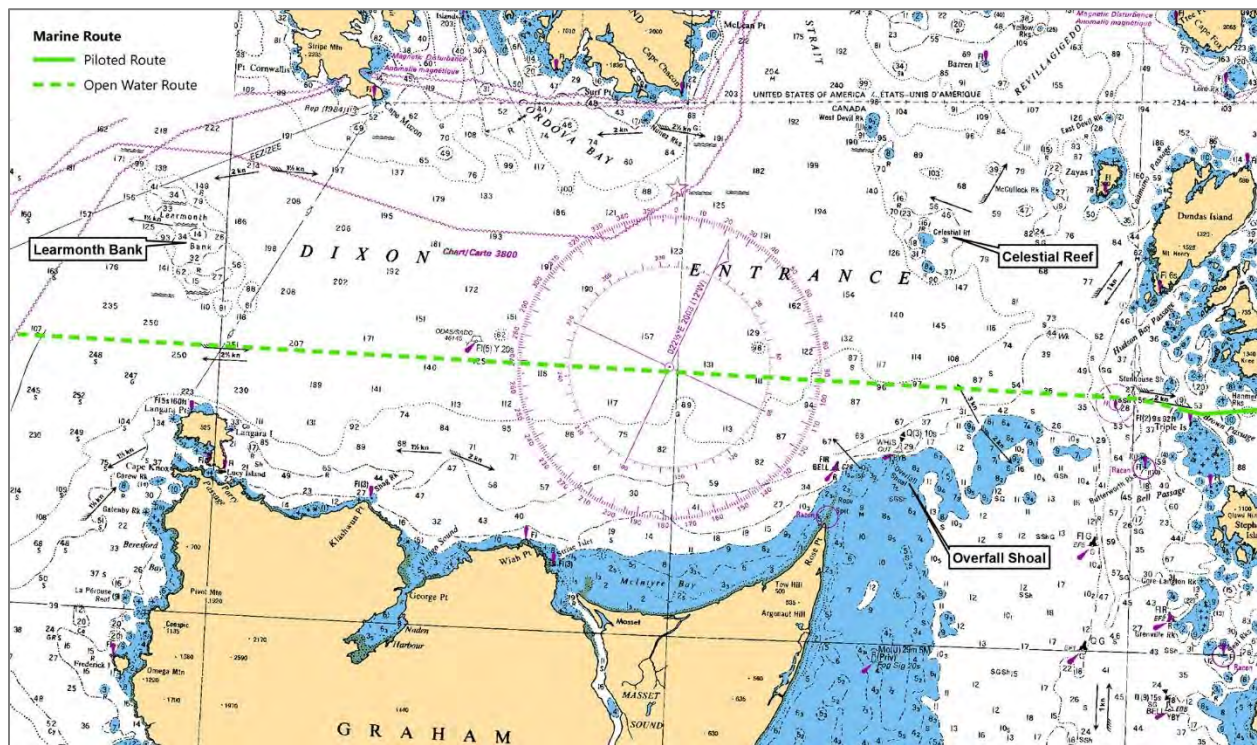

Figure 4 – Marine route from open ocean to the Triple Island pilot boarding station (Canadian Hydrographic Service Chart 3002, depths in fathoms and feet to chart datum)

Dixon Entrance is bordered by Haida Gwaii to the south and the islands of Alaska to the north. At the western end of Dixon Entrance water depths exceed 100 m, except for Learmonth Bank. Learmonth Bank is charted at approximately 26 m depth at its shallowest point but drops steeply away, providing ample room for navigation to the north and south.

The passage to the south of Learmonth Bank has a width of approximately 15 km between Learmonth Bank and Langara Island, with depths ranging from 50 to 250 m. As shown in the *Marine Traffic Report* [8], most cargo vessels use the channel to the south of Learmonth Bank.

East of Learmonth Bank, Dixon Entrance is wide, deep, and free of obstructions for close to 100 km. Water depths in Dixon Entrance generally exceed 100 m. Near Triple Islands depths drop to less than 60 m.

Nowhere along the marine route are depths shallower than approximately 30 m, until the immediate vicinity of the marine terminal berths, providing adequate underkeel clearance for the design vessels.

Towards the eastern end of Dixon Entrance, the marine route approaches Celestial Reef and Overfall Shoal. Celestial Reef is located approximately 35 km west of Dundas Island at a minimum charted depth of 2 m. Celestial Reef is approximately 16 km north of the marine route.

Overfall Shoal is located north-east of Rose Point at the north end of Graham Island. Charted depths range from 6 m at the Overfall Shoal whistle buoy, to 11 m at the northeastern extremity. Overfall Shoal is approximately 3 km south of the marine route.

Dixon Entrance is outside the Compulsory Pilotage Areas (CPAs) defined in the General Pilotage Regulations [9] under the *Pilotage Act* [10]. Vessels subject to compulsory pilotage will be boarded by at least one pilot at the Triple Island pilot boarding station near Triple Islands. Section 5 provides further information on the CPAs.

3.3 Triple Islands to Chatham Sound

The segment of the marine route from the Triple Island pilot boarding station to Chatham Sound is in Figure 5. This section of the marine route is within the CPAs.

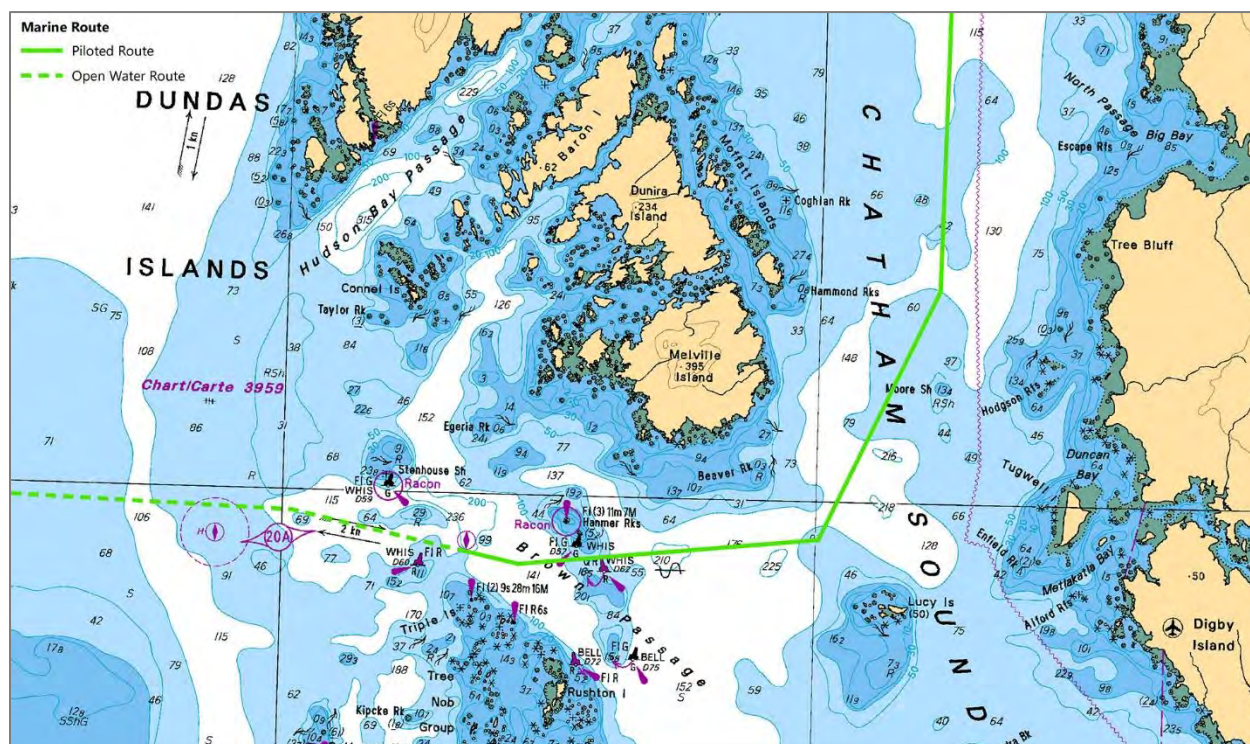

Figure 5 – Marine route from the Triple Island pilot boarding station to Chatham Sound (CHS Chart 3800, depths in metres to chart datum)

Between the Triple Island pilot boarding station to the marine terminal, all LNG carriers and NGL product vessels will be under the guidance of one or more pilots from the BCCP. Two pilot boarding areas are defined near Triple Islands on Canadian Hydrographic Service (CHS) charts. The pilot boarding area used most often is located north of Triple Islands. A second helicopter pilot boarding area is located 10 km west of Triple Islands. Helicopter pilot boarding has been trialled by the PPA and BCCP and may be used in the future. The two pilot boarding areas are collectively called the “Triple Island pilot boarding station”.

3.3.1 Brown Passage

Brown Passage lies between Triple Islands and Melville Island and accesses Chatham Sound. Two deep-draft routes, called the “Northern Route” and “Southern Route”, are defined in the CHS Sailing Directions [11] and shown in Figure 6. Both routes are used by vessels transiting to the Port of Prince Rupert. The selected marine route follows the Northern Route before turning north into Chatham Sound north of Lucy Islands.

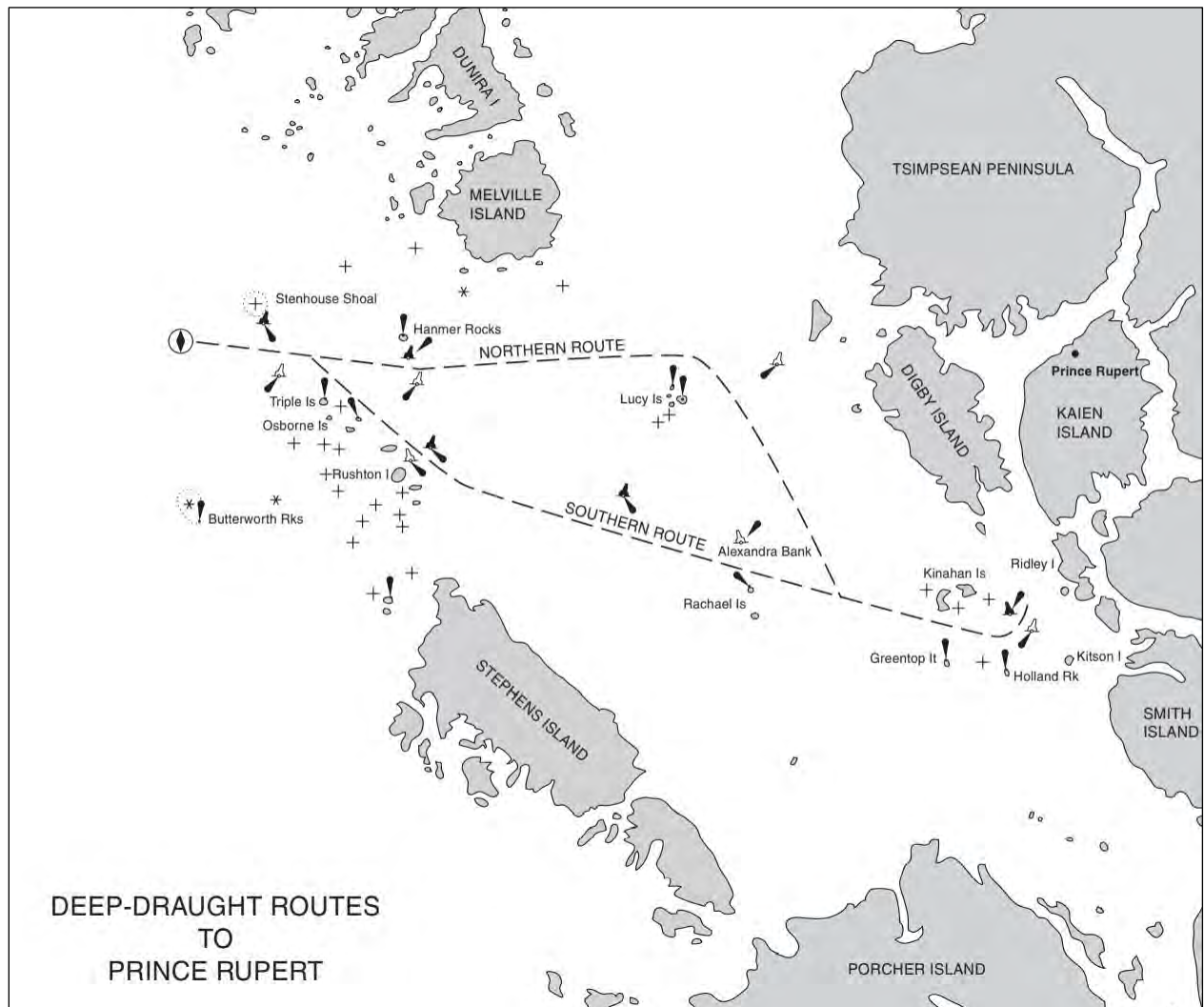

Figure 6 - Northern and southern routes through Brown Passage [11]

The selected marine route passes through Brown Passage between Stenhouse Shoal and a shoal approximately 3 km to the southeast. Stenhouse Shoal is a small reef below chart datum marked by a light and whistle buoy, "D59", fitted with a racon. The shoal to the southeast is marked by the Brown Passage light and whistle buoy, "D60". Brown Passage has charted depths from 37 m to over 200 m.

South of Stenhouse Shoal, Triple Islands is the most northerly point of the Tree Nob Group, a cluster of islands, rocks and reefs extending approximately 7 km north-west from Stephens Island. Triple Islands can be recognized by its three, bare, white, rocky islands 6 to 12 m high, with a large white lighthouse. Triple Islands is marked by a light, on the northwest island, operated in hours of darkness only.

Past Triple Islands, the "Northern Route" and "Southern Route" diverge in Brown Passage. The Northern Route passes through a channel, approximately 1,200 m wide and 29 to 70 m deep, between Hanmer Rocks to the north and a submerged rock at 16.5 m depth to the south. The clearance exceeds the minimum recommended two-way channel width of 790 m, calculated according to World Association for Waterborne Transport Infrastructure (PIANC) publication *Approach Channels, A Guide for Design* [12].

Hanmer Rocks is marked with a light on a tower fitted with a racon. The channel south of Hanmer Rocks is marked with the Hanmer Rocks light and whistle buoy "D57" to the north and whistle buoy, "D62" to the south. East of Hanmer Rocks, the marine route is wide and deep.

3.3.2 Chatham Sound

Chatham Sound connects Brown Passage to Main Passage and Portland Inlet, as shown in Figure 7. Dundas Islands are to the west of Chatham Sound with the Tsimpsean Peninsula to the east. Chatham Sound is free of unmarked hazards except for Moore Shoal, a submerged rock rising to a depth of 13.4 m. Moore Shoal is in the centre of Chatham Sound, approximately 9 km north of Lucy Islands. Moore Shoal does not pose a navigation hazard with the marine route passing approximately 2 km to the west.

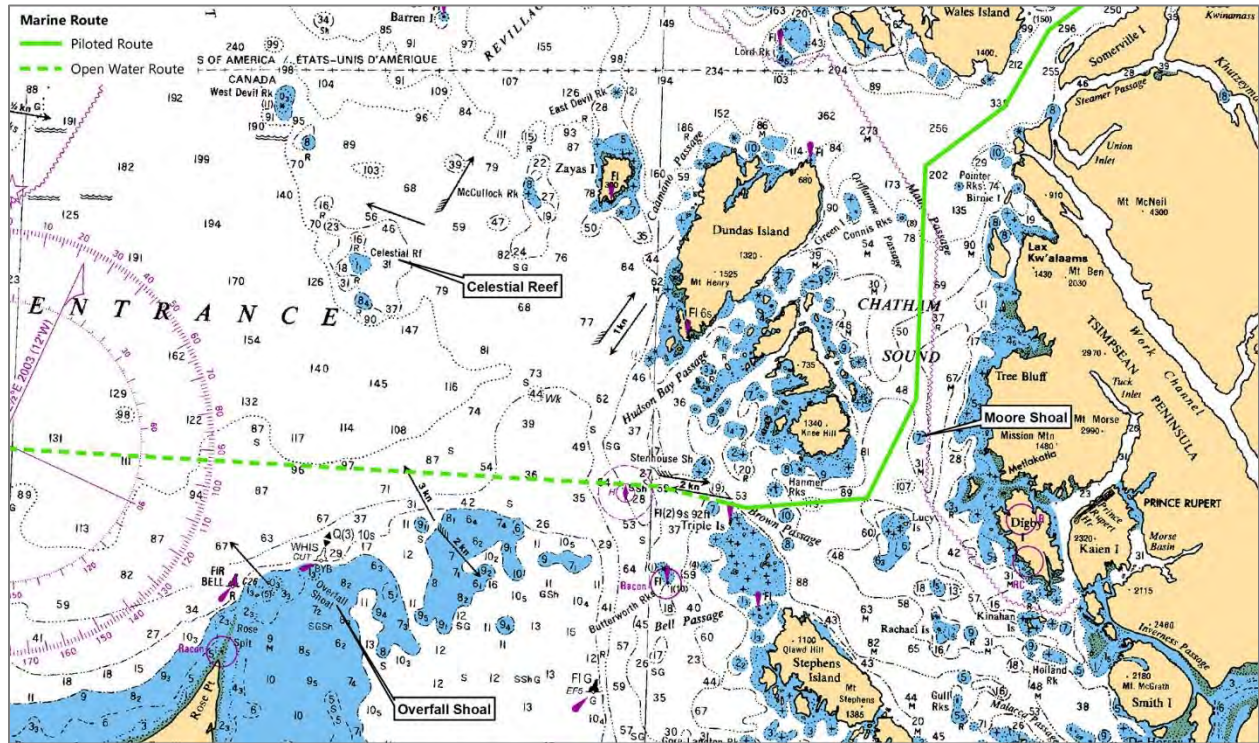

Figure 7 - Marine route from Brown Passage to Main Passage (CHS Chart 3002, depths in fathoms and feet to chart datum)

3.3.3 Main Passage

At the northern end of Chatham Sound the selected marine route enters Main Passage between Connis Rocks to the west and Pointer Rocks to the east. Main Passage is over 5 km wide and over 100 m deep. Connis Rocks is a bare islet 2 m high and marked by a light. Pointer Rocks to the east consists of two large drying reefs also marked by a light.

All Project design vessels are expected to use Main Passage. However, Oriflame Passage is also a viable route for the design vessels [1]. Oriflame Passage lies west of Main Passage between Green Island and Grey Islet to the west and Connis Rocks to the east. Green Island is marked by a lighthouse. AIS data also shows vessels use the passage east of Pointer Rocks [8].

3.4 Portland Inlet to Portland Canal

After Main Passage the marine route turns into Portland Inlet as shown in Figure 8.

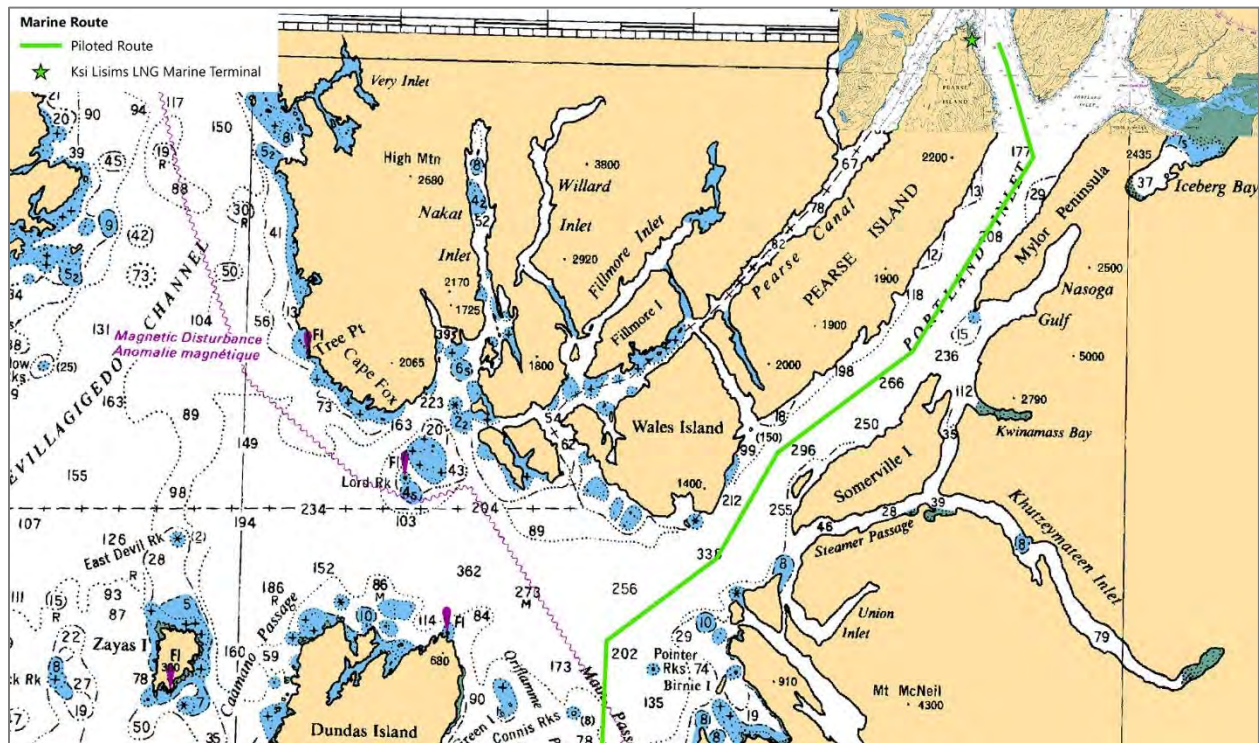

Figure 8 – Marine route from Portland Inlet to Portland Canal (CHS Chart 3002, depths in fathoms and feet to chart datum)

3.4.1 Portland Inlet

Portland Inlet is over 4 km wide with charted depths exceeding 100 m. Portland Inlet is free of unmarked hazards to navigation. Portland Inlet extends approximately 40 km from Main Passage to Portland Canal.

3.4.2 Portland Canal

In Portland Canal, the waterway narrows to approximately 2.6 km in width. Charted depths exceed 100 m until the immediate vicinity of the marine terminal berths. The distance from Portland Inlet to the marine terminal is approximately 6 km. Portland Canal exceeds the minimum recommended two-way channel width of 500 m, calculated according to PIANC publication *Approach Channels, A Guide for Design* [12].

3.5 Transit Speeds

LNG carriers will transit from open waters into Dixon Entrance at a speed appropriate for the prevailing weather conditions and expected time of arrival (ETA) at the pilot boarding station. LNG carrier speeds are expected to average 16 kn through Dixon Entrance into Brown Passage. Further details of the service speeds of the design vessels are found in the *Vessel Specification Report* [1]. As LNG carriers and NGL product vessels approach Triple Islands they will reduce their speed for pilot boarding, with the speed reduction typically completed over approximately an hour.

The recommended speed profile for LNG carriers and NGL product vessels along the marine route will be defined during the NRA with participation from the PPA and the BCCP.

4 Metocean Conditions

LNG carriers and NGL product vessels consider weather forecasts and weather conditions as part of their operating procedures. LNG carriers and NGL product vessels will also use pilot knowledge to navigate safely in adverse weather [6]. LNG carriers and NGL product vessels consider these factors when planning their voyage [6]:

- Vessel performance characteristics
- Shipping route navigation characteristics
- Long-term weather forecasts
- Real-time weather
- Vessel company requirements
- Marine terminal requirements
- Pilot and vessel traffic services advice and guidance

By the time the Project is operational, real-time weather data for the marine terminal will be available.

4.1 Precipitation and Visibility

Moderate coastal waters combined with cold outflow from interior valleys during winter means a wide range of precipitation types is found on the BC coast [13]. Visibility can be reduced by rain, snow, or by low hanging cloud cover and fog. Rain is the most common of these events. Rain that causes a significant decrease in visibility is rare as precipitation is often accompanied by wind and no fog.

Sea fog in the region is more common during summer (i.e., June through September) than during fall or winter (i.e., October through March) [14]. Fog is more prevalent over the approaches to Dixon Entrance than closer to the mainland with fog present 10% to 15% of the time from August to September, 5% of the time in March and April, and approximately 10% of the time from May through July [14].

Assessment of thick fog from hourly historic weather data at the Port of Prince Rupert shows that, from 2017 to August of 2022, visibility in the region only dropped below 3 km on average 13 days a year, or 3.6% of the time [15]. Table 3 is fog observations taken at Triple Islands Lighthouse over 14 years [16]:

Table 3 – Triple Islands fog observations

Location	Percentage of Observations When Fog was Present (Observations Four Times Per Day)											
	Jan	Feb	Mar	Apr	May	Jun	Jul	Aug	Sep	Oct	Nov	Dec
Triple Islands	1.2	1.8	0.9	1.2	2.6	5.2	7.1	8.5	6.9	1.3	0.9	1.6

Poor visibility is mitigated by modern navigational instruments on all design LNG carriers and NGL product vessels. BCCP will be responsible for ensuring LNG carriers and NGL product vessels proceed at a safe speed for the prevailing weather conditions.

Poor visibility is also mitigated by the physical ATON present along the marine route. A list of existing ATON is provided in Appendix B. As described in Section 6.1.3, the Canadian Coast Guard (CCG) regularly reviews ATON and plans to review ATON in the areas of Portland Inlet and Portland Canal.

4.2 Temperature and Icing

Surface seawater temperatures in the region vary throughout the year based on solar energy, sea currents and freshwater runoff, with average sea surface temperatures ranging from about 6°C in April to 14°C in August [17]. Channels along the North Coast are generally ice-free, year-round. The exception is occasional freezing events which can cause thin ice to form at the head of smaller northern inlets.

Sea ice has not historically been an issue for vessels passing by the Site transiting to the Port of Stewart, at the head of Portland Canal. Stewart advertises itself as “Canada’s most northerly ice free port” [18]. Sea ice is not expected to be a concern for LNG carriers and NGL product vessels.

Icing on the ships’ superstructure can occur when air temperatures are -2°C or lower, with moderate or strong wind. During outflow conditions (described in Section 4.4), wind can cause ice buildup on the windward side of vessels. The probability of these conditions in BC waters is less than 5% [17]. The high freeboard of all LNG carriers will limit ice accretion on the deck and superstructure. There is no history of icing being problematic at ports on the North Coast.

4.3 Storm Events

Storms along the BC coast are infrequent but can be large, producing powerful wind events. Storms on the coast of BC are most common in the fall and winter months. Duration of individual storms is often one to two days while the interval between storms varies from one to five days [17]. Periods of up to two weeks in fall and winter may elapse without storms [17].

For coastal channel areas, most storm systems are obstructed by land, diminishing wind speeds relative to the open ocean. This is the case for the inner segments of the marine route in Chatham Sound and Portland inlet relative to the open waters of Dixon Entrance.

4.4 Wind

Historical wind records from Prince Rupert [17] and Holland Rock [19], west of Prince Rupert, are provided in Table 4 and Table 5.

Table 4 - Maximum wind speeds at Prince Rupert [17]

Elevation: 34.4 m	Prince Rupert 54°17'N 130°26'W - Active Station												
	Jan	Feb	Mar	Apr	May	June	July	Aug	Sep	Oct	Nov	Dec	Year
Wind (m/s)													
Speed	4.0	4.1	4.0	4.0	3.6	3.1	2.7	2.7	3.0	4.0	4.1	4.2	3.6
Most Frequent Direction	SE	SE	SE	SE	SE	W	W	SE	SE	SE	SE	SE	SE
Maximum Hourly Speed	24.7	20.6	19.4	20.6	17.8	15.3	17.8	15.0	20.8	25.8 ^a	24.7	24.2	-

Elevation: 34.4 m	Prince Rupert 54°17'N 130°26'W - Active Station												
	Jan	Feb	Mar	Apr	May	June	July	Aug	Sep	Oct	Nov	Dec	Year
Wind (m/s)													
Direction Max. Hourly Speed	SE	S	SE	S	SE	SE	SE	S	S	SE	SE	SE	SE
Maximum Gust Speed	31.9	31.4	31.4	30.3	26.7	21.1	17.8	19.4	26.7	37.5	38.1 ^b	36.9	-
Direction Maximum Gust	SE	S	SE	S	SE	SE	SE	SE	S	SE	SE	SE	SE

^aAll-time extreme (1964/18)

^bAll-time extreme (1968/28)

Table 5 - Wind speed return intervals at Holland Rock [19]

Return Periods	Wind Speed at Holland Rock	
	(m/s)	(kn)
1 - year	19.4	37.7
5 - year	26.1	50.7
10 - year	28.1	54.6
25 - year	30.6	59.5
50 - year	32.5	63.2
100 -year	34.2	66.5

A metocean study of the conditions at Wil Milit included deploying wind, current and wave monitoring equipment near the Site for six months, including the winter storm season, from August 2021 to February 2022 [20]. The measured winds at Wil Milit are low, not exceeding 9.3 m/s over the six-month period. The low values are believed to be due to the protection provided by the topography surrounding Wil Milit.

The metocean study included analysis of wind readings at Grey Islet, located east of the Dundas Island group at the northern end of Chatham Sound, near Main Passage. The location of Grey Islet is aligned with the longitudinal axis of Portland Inlet. Grey Islet wind statistics can characterize the winds in Chatham Sound and winds in Portland Inlet and Portland Canal (e.g., wind in northeast and southwest directions). The wind roses for Wil Milit and Grey Islet are shown in Figure 10. Estimated statistical extremes for the Grey Island values are in Table 6.

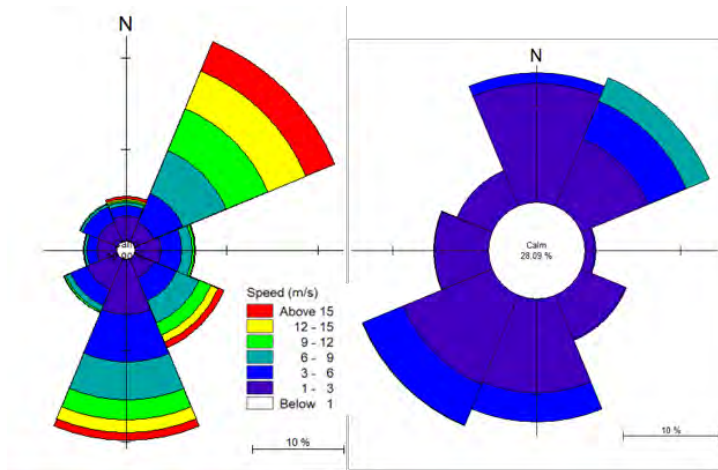

Figure 10 - Wind Rose for Grey Islet, 1994-2022 (left); and Wil Milit, 2021-2022 (right) [20]

Table 6 - Extreme wind speed estimated using Grey Islet records (1994-2022) [20]

Return Period (Years)	Omni [m/s]	N [m/s]	NE [m/s]	E [m/s]	SE [m/s]	S [m/s]	SW [m/s]	W [m/s]	NW [m/s]
1	27.0	16.2	25.7	15	23.2	24.6	16.9	14.1	12.8
10	32.4	29.2	31.3	20.3	32.4	29.5	22.3	18.5	18.7
25	35.6	33.7	33.2	22.2	35.6	31.2	24.2	20.0	20.8
50	38.0	37.0	34.7	23.5	38.0	32.5	25.6	21.1	22.3
100	40.4	40.4	36.1	24.9	40.4	33.8	27.0	22.3	23.9
10,000	62.5	62.5	45.6	34.0	56.2	42.3	36.3	29.8	34.0

Outflow winds can produce winds over 25 m/s (49 kn) [17]. Infrequently, inflow winds can also reach gale force of 18 m/s to 24 m/s (35 to 47 kn) [17] [21]. Outflow winds dissipate as they reach the mouths of coastal inlets, but the effects can be experienced beyond coastal inlets. This can be seen in the wind rose for Grey Islet (see Figure 10), located approximately 16 km from the mouth of Portland Inlet, subject to northeast outflow winds.

4.5 Waves

The coast of BC is subject to swells arriving from the Pacific Ocean and locally generated waves from storm events. Dixon Entrance experiences wave conditions representative of conditions in the North Pacific. Once past the Triple Island pilot boarding station, waves are smaller in Chatham Sound. The waves and swell from the open waters of Dixon Entrance and Hecate Strait are reduced by the islands surrounding Stephens Island and Dundas Islands.

East of Learmonth Bank in Dixon Entrance, from June to August, the mean significant wave height is 1.2 m, with a maximum significant wave height of 3.5 m [17]. From December to February the mean significant wave height is 2.9 m, with a maximum significant wave height of 7.3 m [17]. The maximum wave height recorded is 13.6 m [17].

Readings in Chatham Sound, 2.4 km west of Prince Rupert Harbour, showed most waves to be less than 1 m high with periods of 2 to 5 seconds [14]. Low swells entering Chatham Sound from Dixon Entrance were common, with only 10% of swells higher than 1 m [14]. During a 10 month observation period, the significant wave height never exceeded 3 m [14].

A metocean study [20] modelled the wave climate at the Site using wind data from Grey Islet at the northern end of Chatham Sound. The results of the assessment are summarized in Table 7. The wave climate at the Site is mild due to the protection provided by the topography surrounding the Site.

Table 7 - Simulated extreme wave parameters at the Site (424718 E, 6097852 N) [20]

Return Period (Years)	Storm from Northeast			Storm from Southwest		
	Hs [m]	Tp [s]	Mean Wave Direction (deg)	Hs [m]	Tp [s]	Mean Wave Direction (deg)
1	1.2	3.7	NNE	0.7	4.3	SSE
10	1.5	4.1	NNE	1.0	5.2	SSE
25	2.0	4.4	NNE	1.1	5.2	SSE
50	2.2	4.7	NNE	1.2	5.3	SSE
100	2.6	4.8	NNE	1.3	5.4	SSE
10,000	2.9	5.2	NNE	1.6	6.1	SSE

4.6 Vessel Wake

Past studies have found that waves created by LNG carriers and tugs, when operating under normal conditions, are comparable to natural wave conditions found in coastal channels. Wave heights from LNG carriers travelling at speeds up to 16 kns have been estimated to be in the order of 0.1 m at shore, while tugs travelling at 12 to 16 kn are estimated to generate waves of 0.2 to 0.3 m at shore [22].

4.7 Tides and Currents

Tides for Prince Rupert are provided in Table 8 [23] and represent tide levels found along the marine route. Detailed tidal information will be defined for the marine route and marine terminal and included in the Terminal Operations Manual [24].

Table 8 - Prince Rupert tidal levels

Tidal Plane	Level [m Chart Datum]
Highest recorded	8.0
HHWLT	7.4
HHWMT	6.2
MSL	3.8
LLWMT	1.3
LLWLT	0.0
Lowest recorded	-0.4

Tides at the Site will be similar to tides at Gingolx (see Table 9), approximately 15 km to the east of the Site. Tides for Gingolx are in Table 9 and are referenced from Prince Rupert using Volume 7 of the Canadian Tide and Current Tables [23].

Table 9 - Forecast tidal levels at Gingolx

Tidal Plane	Level [m Chart Datum]
HHWLT	7.5
HHWMT	6.1
MSL	3.8
LLWMT	1.2
LLWLT	-0.2

Flood tides which enter Dixon Entrance along the north shore of Graham Island split with one stream heading north into Alaskan waters and the other pushing south through Hecate Strait. Dixon Entrance tidal streams normally reach 3 kn (1.5 m/s), which decreases at Portland Inlet as the main flow breaks around the coast and the Dundas Islands.

Due to the spring runoff and fall rains that enter coastal channels, the ebb tides are generally stronger than flood tides along the BC coast, especially in inlets due to their constrained nature. Data on tidal currents for the North Coast is available through publications from CHS and Fisheries and Oceans Canada (DFO) [25].

A metocean study [20] measured nearshore currents near the Site using a A-TRDI 600 kHz WorkHorse Acoustic Doppler Current Profiler (ADCP) in 22 m deep water. Current statistics for three depths are provided Table 10. Currents exceed 50 cm/s (approximately 1 kn) for 8% of the time with a maximum recorded current of approximately 91 cm/s (approximately 1.8 kn). The depth averaged current is estimated to be 22 cm/s (less than 0.5 kn).

Table 10 - Current speed (cm/s) near the Site [20]

Location	Speed (cm/s)					
	Min	Mean	95%	99%	std	Max
5.8 m below surface	0.1	23.1	55.8	70.6	16.7	90.8
10.6 m below surface	0.1	22.4	55.5	68.7	16.7	90.2
18.6 m below surface	0.1	20.3	49.4	60.4	14.9	78.9

Storm events may increase or decrease the tidal stream effects by 1 kn (0.5 m/s) or more. Design vessels should be prepared for rare events with tidal currents of 4 to 6 kn (2 to 3 m/s) or more, with the largest flows found at the entrances to the coastal network. The flood and ebb tides generally follow the orientation of the marine channels, and with speeds typically less than 3 kn (1.5 m/s) and do not pose a hazard to navigation.

4.8 Summary

LNG carriers and NGL product vessels are designed for the conditions in the Pacific Ocean and Dixon Entrance. A consideration with respect to metocean conditions is pilot boarding and disembarking near Triple Islands. LNG carriers and NGL product vessels will receive instructions from the BCCP on the speed and course to provide safe conditions for pilot boarding.

During severe storms, weather conditions can delay pilot boarding or necessitate vessels to follow the pilot boat into more sheltered waters. Storm conditions can be forecast in advance and LNG carriers and NGL product vessels can adjust their arrival time for a better weather window at the Triple Island pilot boarding station. Adverse weather in the Prince Rupert area only resulted in delays to pilot boarding 2 to 3 times over a 14 year period, and pilot boarding was never delayed by more than 6 hours [26].

5 Compulsory Pilotage Areas

The CPAs on Canada’s west coast are defined in the General Pilotage Regulations [27] under the *Pilotage Act* [10]. The CPAs near the marine route, is shown in Figure 11. Pilotage on the west coast of Canada is administered by the PPA with pilotage provided by the BCCP.

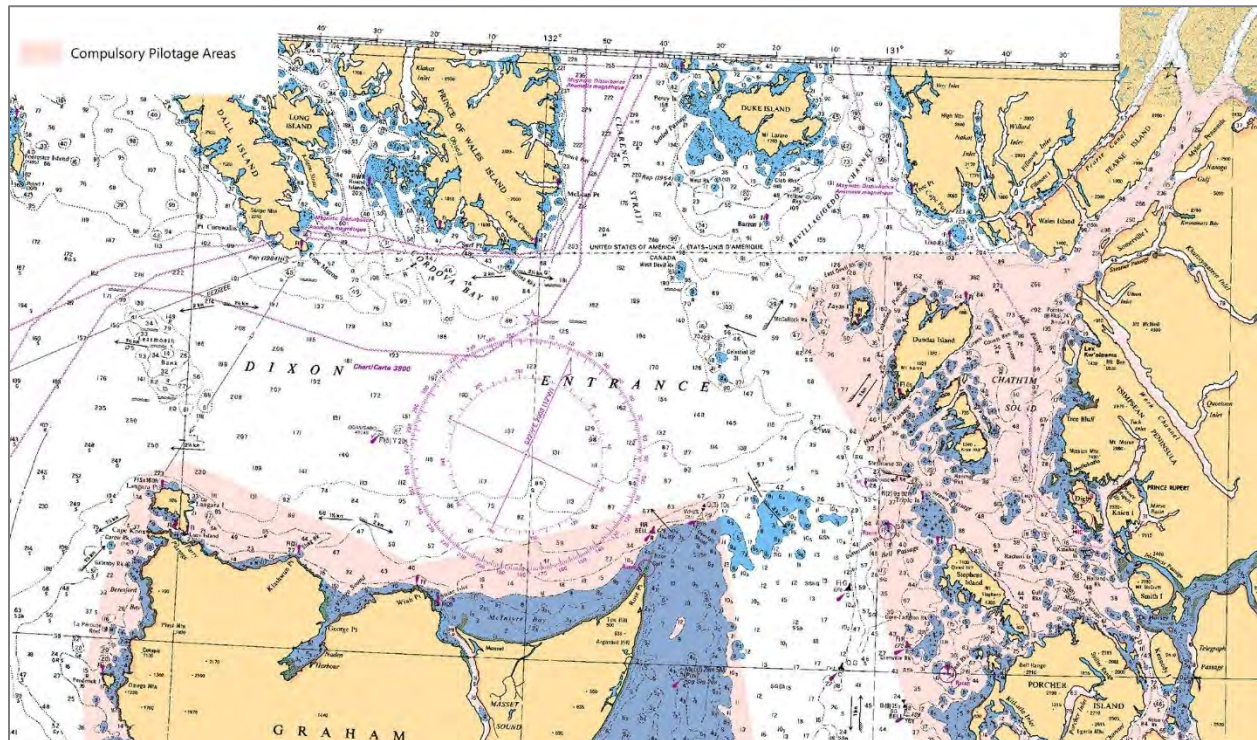

Figure 11 - Compulsory Pilotage Areas (CHS Chart 3002, depths in fathoms and feet to chart datum)

LNG carriers and NGL product vessels will enter the CPAs at the Triple Island pilot boarding station. LNG carriers and NGL product vessels must provide advanced notice to the PPA, requesting a pilot. Between the Triple Island pilot boarding station to berthing at the marine terminal, all LNG carriers and NGL product vessels will be under the guidance of one or more pilots from the BCCP.

5.1 Triple Island Pilot Boarding Station

Two pilot boarding areas are defined near Triple Islands on CHS charts as shown in Figure 12. The pilot boarding area used most often is located north of Triple Islands. A second helicopter pilot boarding area is located 10 km west of Triple Islands.

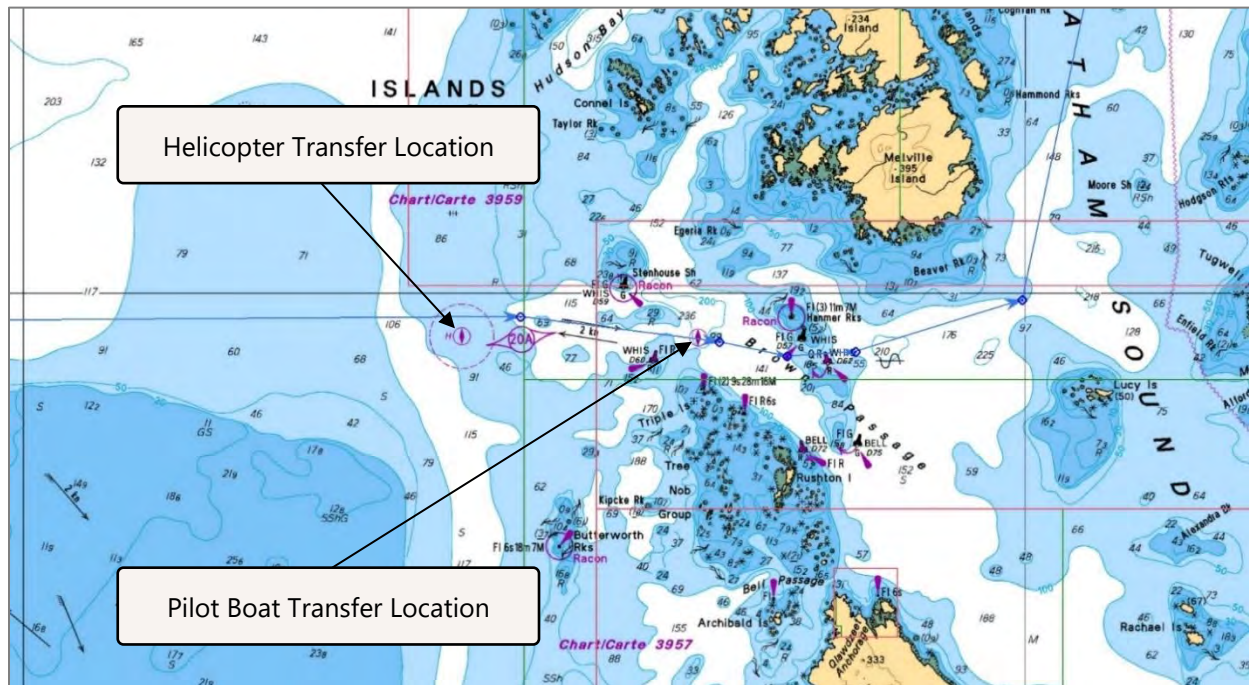

Figure 12 - Triple Island pilot boarding station (CHS Chart 3800, depths in metres to chart datum)

5.2 Helicopter Pilot Boarding

Helicopter boarding can provide these benefits:

- Helicopter boarding increases the safety and efficiency of boarding pilots in adverse weather conditions, allowing vessels to maintain a safe transit speed
- Helicopter transfer significantly reduces the pilot transfer time (e.g., travel to the boarding station by boat can take up to 1.5 hours from Prince Rupert or 12 to 14 minutes by helicopter [22])
- Helicopters have the flexibility of transferring to and from vessels at alternate locations when the concentration of smaller vessels warrants, such as during fisheries openings [4]

Helicopter boarding operations follow guidelines including:

- Metocean operating limits
- Transport Canada's Guidelines Respecting Helicopter Facilities on Ships (TP 4414)
- International Chamber of Shipping Guide to Helicopter / Ship Operations

Further information on helicopter pilot boarding can be found in the PPA Notice to Industry 08/2015 issued on November 24, 2015 [28]. Pilot boarding by helicopter has been suspended by the PPA since 2016, but may be resumed when vessel traffic and needs require [22].

Past studies have recommended continuous weather data at Triple Islands could assist helicopter boarding of marine pilots [4]. The Prince Rupert Port Authority (PRPA) now provides live weather data for Triple Islands [13].

5.3 Pilot Demand

At the Triple Island pilot boarding station, at least one pilot will board all LNG carriers and NGL product vessels. At least one pilot will also be on board all LNG carriers and NGL product vessels from the marine terminal to Triple Islands on the outbound transit.

Records from PPA [29], show 523 piloted movements occurred starting at the Triple Island pilot boarding station in 2021. Project operations are not forecast to begin until 2028 [30], providing time for the PPA and BCCP to plan for the Project. By the start of operations, at least one other LNG export terminal will be operating, and the PPA and BCCP will have gained additional experience with LNG operations.

6 Navigation and Vessel Traffic Services

ATON and vessel traffic services on the coast of BC include:

- Nautical charts provided by the CHS, part of Fisheries and Oceans Canada (DFO) [31]
- Sailing Directions published by the CHS that describe the waterways along Canada's west coast and services available to mariners [32]
- Annual, monthly, temporary, and preliminary Notices to Mariners (NOTMAR) maintained by the CCG, with information to update charts and nautical publications [33]
- Navigational warnings (NAVWARNs) issued by the CCG containing information about changes to ATON and marine activities or hazards, such as ATON defects, dredging, fishing zones and military exercises [34]
- Tide tables published by DFO [25]
- Marine weather forecasts published by Environment and Climate Change Canada (ECCC) [35]
- Pilotage within the CPAs, provided by BCCP and administered by the PPA [9] [10]
- Navigational aids listed in the *Pacific Coast List of Lights, Buoys and Fog Signals* [36] maintained by the CCG
- Marine communications and vessel traffic services and mandatory radio call-in points [37] managed by the CCG
- The automatic identification system (AIS) for tracking vessel positions [38]

6.1 Navigational Aids

ATON assist mariners in determining position and course, to warn of hazards or obstructions or to advise of the location of the best or preferred route [39]. Navigation aids in Canadian waters are administered by the CCG [40] and include 17,000 short-range ATON including buoys, leading marks (ranges), and position confirmation lights. The CCG's Service Standard dictates the overall target level for operational reliability for the short-range ATON system is 99%, calculated over a three-year period.

6.1.1 Existing Lights, Buoys and Fog Signals

The existing ATON along the marine route are listed in Appendix B. Areas with relatively high traffic density in Dixon Entrance and Chatham Sound have a network of lights and buoys. From the northern end of Chatham Sound to Portland Canal there are fewer navigational aids. This is due to the relatively low traffic density and the lack of navigation hazards. In Portland Inlet, there are no shoals or obstructions between the steep shores, which can be observed visually and with radar.

6.1.2 Radar Beacons

Racons are a method of producing a radar-enhanced target by using an active device (rather than a passive reflector). Typical range is 6 to 8 nm for a racon fitted to a buoy, and 10 to 20 nm when installed on a shore structure. There are two racons along the marine route (see Appendix B):

- Hanmer Rocks
- Stenhouse Shoal light and whistle buoy "D59"

There is one additional racon at Rose Spit.

6.1.3 Improvements to Aids to Navigation

Improvements to ATON will be recommended by the CCG as part of their ongoing LOS reviews. Navigation of the marine route and berthing at the marine terminal will be further assessed using FMBS during the NRA with the participation of the PPA and BCCP. An outcome of the NRA will be recommendations for ATON at the marine terminal and improvements to ATON along the marine route, if required.

6.1.3.1 Marine Terminal

Marine terminal ATON will be developed during detailed project planning and the NRA. Marine terminal ATON will be designed and installed to acceptable guidelines (i.e., the International Association of Marine Aids to Navigation and Lighthouse Authorities [IALA] or CCG). ATON will be in place before the start of operations and communicated in the Terminal Operations Manual [24].

6.1.3.2 Marine Route and Level of Service Review

The CCG have completed LOS reviews of ATON in Chatham Sound north to Green Island. The CCG plans to review the area of Green Island to Portland Inlet and Portland Canal. This LOS review is planned to be completed before the start of Project operations. LOS reviews include input from stakeholders including the PPA and BCCP.

The CCG does not provide ATON that benefit a single or a small number of users. The CCG provides ATON where the volume of traffic justifies and hazards require ATON [41]. The Project will assist with the provision of ATON, if requested by the CCG.

6.1.4 Virtual Aids to Navigation

The CCG is introducing AIS aids to navigation (AIS ATON) and Virtual AIS aids to navigation (V-ATON), where hazards are indicated by AIS, instead of physical installations intended to be seen or heard. This technology means it is possible to display information on navigation equipment that visual observation could not detect. V-ATON is also beneficial where the deployment of physical aids to navigation is not practicable and other means of communication are restricted.

These new ATON technologies require a period of adaptation for mariners to assess the accuracy and added value related to safe navigation [38]. To gain confidence with the new technology, the CCG is using supervised test beds involving three types of AIS ATON. The test beds are in the Western, Central, Arctic, and Atlantic regions in sites determined in collaboration with Canadian pilots.

6.2 Navigational Charts

The Navigation Safety Regulations, 2020 [42] *under the Canada Shipping Act, 2001* [43] require LNG carriers and NGL product vessels to carry:

- The reference catalogue and the applicable charts referred to in the catalogue in their largest scale, published by or under the authority of the CHS
- The *Notices to Mariners, Annual Edition* [44]
- Sailing directions, published by the CHS [32]
- Canadian tide and current tables, published by the CHS
- *Pacific Coast List of Lights, Buoys and Fog Signals*, published by the CCG [36]
- *Radio Aids to Marine Navigation*, published by the CCG [45]

The Navigation Safety Regulations, 2020 [42] allows charts to be in electronic form if it is displayed on an electronic chart display and information system (ECDIS). The ECDIS must have a backup arrangement, which could include paper charts. Table 11 lists the CHS charts applicable to the marine route.

Table 11 - CHS Charts applicable to the marine route

Navigational Area	CHS Nautical Chart Numbers
Dixon entrance	3000, 3002, 3800
Chatham Sound	3957, 3959, 3960, 3963
Portland Inlet and Portland Canal	3933, 3994

All LNG carriers and NGL product vessels also must be fitted with the most up-to-date navigational charts as part of their class and flag state requirements, confirmed by the Ship Inspection Report Programme (SIRE) Programme (see *Vessel Specification Report* [1]).

The CHS is phasing out raster navigational charts (RNCs) to offer safer electronic navigational chart (ENC) products and services [46]. RNCs are simply a digital image, whereas ENCs are interactive and provide value-added information that enables safer navigation.

CHS will continue to support global navigation satellite system (GNSS) users by offering ENC in S-57 format and non-GNSS users by continuing to offer paper charts.

Past studies have recommended the CHS work with Transport Canada and the PPA to consider precautionary notes on charts to provide awareness of marine terminal locations and the locations along the marine route where LNG carriers and NGL product vessels can be expected [22].

6.3 Regional Radio Communications Infrastructure

6.3.1 Marine Communications and Traffic Services

The CCG Marine Communications and Traffic Services (MCTS) provide several regional navigation communication services, as described in *Radio Aids to Marine Navigation (Atlantic, St. Lawrence, Great Lakes, Lake Winnipeg, Arctic and Pacific)* [45]. The network of MCTS sites and centres for the Pacific region is shown in Figure 13. This area of the coast is coordinated from the MCTS centre in Prince Rupert.



Figure 13 - MCTS centres and remote controlled sites [37]

Vessel Traffic Services Zones Regulations [47] apply to all vessels 20 m or more in length. The marine route passes through “Sector 2” of the “Prince Rupert North” vessel traffic services (VTS) zone in Figure 14. In Sector 2, “Prince Rupert Traffic” operates on channel 71 at 156.575 MHz. Prince Rupert MCTS broadcasts regional navigation warnings (NAVWARN), weather forecasts, and ocean buoy reports. A full listing of the locations, times and information can be found in Table 2 to 18 of Radio Aids to Marine Navigation [45].

Mariners will be informed by MCTS of LNG carriers and NGL product vessels transiting to and from the marine terminal. MCTS informs mariners that are within a VTS zone or otherwise participating in the system in accordance with the Vessel Traffic Services Zones Regulations. LNG carriers and NGL product vessels outbound from the marine terminal will first communicate with MCTS fifteen minutes prior to entering the VTZ zone at calling-in-point 19 (i.e., Wales Point, a line joining Wales Point to Maskelyne Point [see Figure 19]).

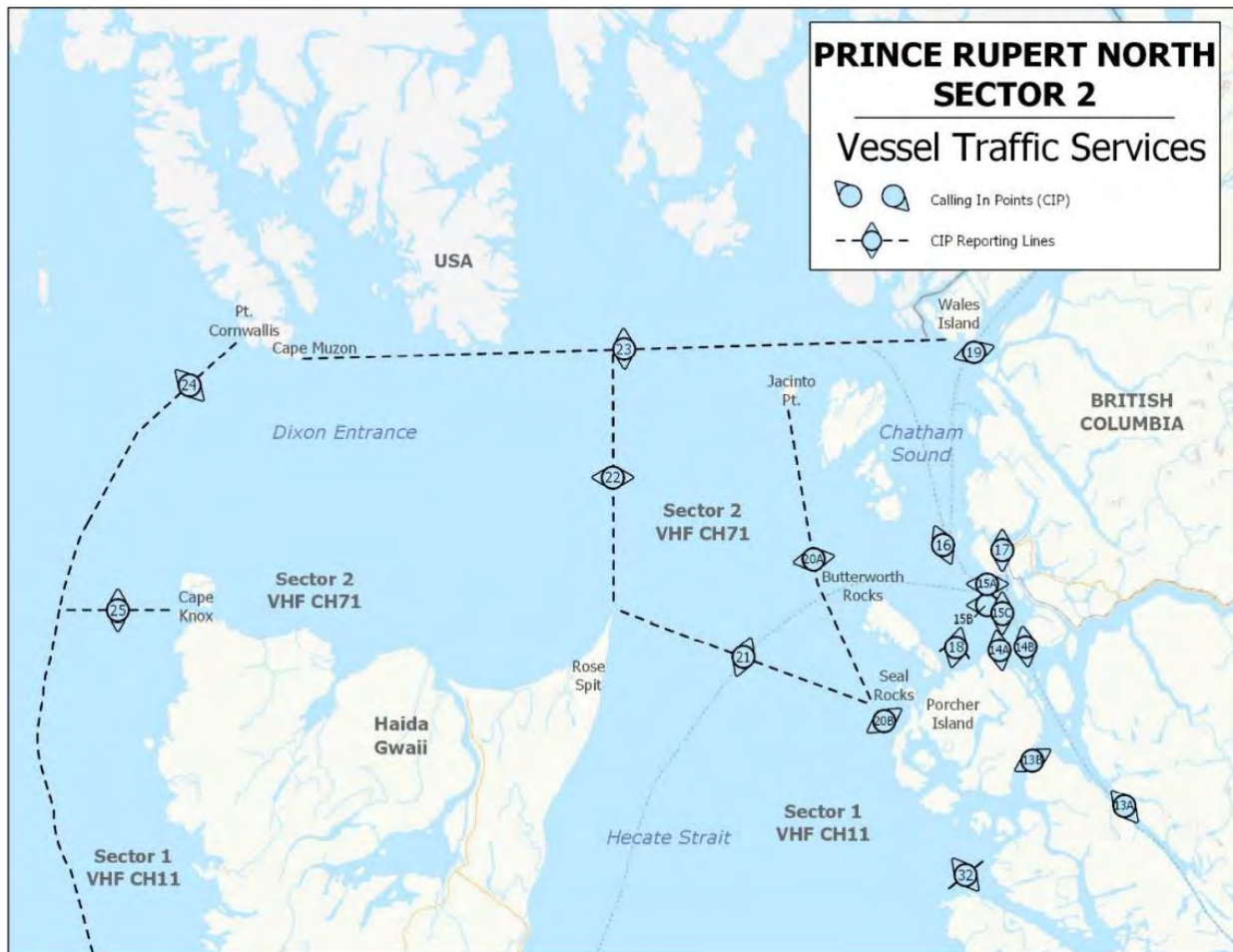

Figure 14 - Vessel Traffic Services - Prince Rupert North - Sector 2, extents and calling-in points [45]

6.3.2 Pre-Arrival Information Reports

Pre-Arrival Information Reports (PAIR) are made under the Marine Transportation Security Regulations [48] under the *Marine Transportation Security Act* and are described in the CCG's Radio Aids to Marine Navigation [45]. Vessels of 500 gross tonnage or more must provide a report to Transport Canada Marine Security Operations Centre (MSOC) West, 96 hours before entering Canadian waters.

6.3.3 Advanced Reporting Requirements

Vessel Traffic Services Zones Regulations [43] under the *Canada Shipping Act, 2001* require all vessels greater than 500 gross tonnage, to file a VTS offshore report 24 hours before entering a Canadian VTS zone from seaward [22].

The report contains information such as the vessel's position, course, and speed, destination and intended route, dangerous goods or pollutants, any defects, and expiration dates of various required certificates. Vessels need clearance from the MCTS before entering a VTS zone [22].

6.3.4 Entering a VTS Zone and Call-In Points

LNG carriers and NGL product vessels must report to MCTS centres at calling-in points described in the Vessel Traffic Services Zone Regulations [43] under the *Canada Shipping Act, 2001* [43]. While operating within the Prince Rupert VTS zone, LNG carriers and NGL product vessels will communicate with the CCG

and will be monitored using the CCG AIS and shore-based radar [49]. Vessels who are not entering a VTS zone from seaward (e.g., an LNG carrier outbound) are required to make a report to MCTS 15 minutes before the ship enters a VTS zone per the Vessel Traffic Services Zones Regulations [43].

Call-in points for the marine route are in Table 12. The CCG, BCCP, and the PPA may reassess calling-in points when new projects are introduced [22] [6].

Table 12 - Calling-in points along the marine route [45]

Number	Sector	Name	General Description and Conditions	Geographic Description
24	2	Zone Limit	A line running from Point Cornwallis light extending on a southwestward arc following the limit of the Territorial Sea to 54°11'00"N 133°28'34.6"W.	A line running from: 54°42'12"N 132°52'17"W; to 54°11'00"N 133°28'34.6"W along the limit of the Territorial Sea.
22	2	Rose Spit	A line extending 000° (True) from Rose Spit to the International Boundary.	A line running 000° (T) from 54°11'12.5"N 131°38'43"W to the International Boundary.
20A	2	Butterworth Rocks	A line from Jacinto Point light to Butterworth Rocks light thence to Seal Rocks light. Mariners shall report routing if not using Brown Passage.	A line running from: 54°34'47"N 131°04'30"W to 54°14'08"N 130°58'30"W, thence 54°00'00"N 130°47'26"W.
19	2	Wales Point	A line joining Wales Point to Maskelyne Point.	A line running from: 54°42'17"N 130°28'33"W to 54°38'55"N 130°26'42"W.

The Site is currently outside of the Prince Rupert VTS zone boundary. As such, MCTS does not provide VTS services (i.e., including monitoring) at the Site and there is no radar coverage. VHF radio and AIS coverage can be unreliable at the Site due to the topographical constraints and that the closest peripheral site is solar powered. The Project will work with applicable agencies to investigate the feasibility of added communication services and ATON, where necessary, along the marine route.

6.3.5 Global Maritime Distress and Safety System in Canada

The Global Maritime Distress and Safety System (GMDSS) is an international system to alert authorities in the event of an emergency. The system also alerts vessels near a distress signal. GMDSS requirements were developed through the International Maritime Organization (IMO). All LNG carriers and NGL product vessels must comply with international GMDSS requirements under the *International Convention for the Safety of Life at Sea (SOLAS), 1974*.

The GMDSS includes Maritime Safety Information (MSI) broadcasts, which comprise navigational and meteorological warnings, meteorological forecasts, and other safety-related messages.

The marine route is within GMDSS Canadian Sea Area A1, which encompasses areas within range of shore-based VHF / DSC coast station (i.e., 40 nautical miles). There are ten NAVTEX transmitters in Canada, transmitting at a frequency of 518.0 kHz. The relevant transmitter for the marine route is at Digby Island, administered by Prince Rupert MCTS and has a range of 300 NM as shown in Figure 15.

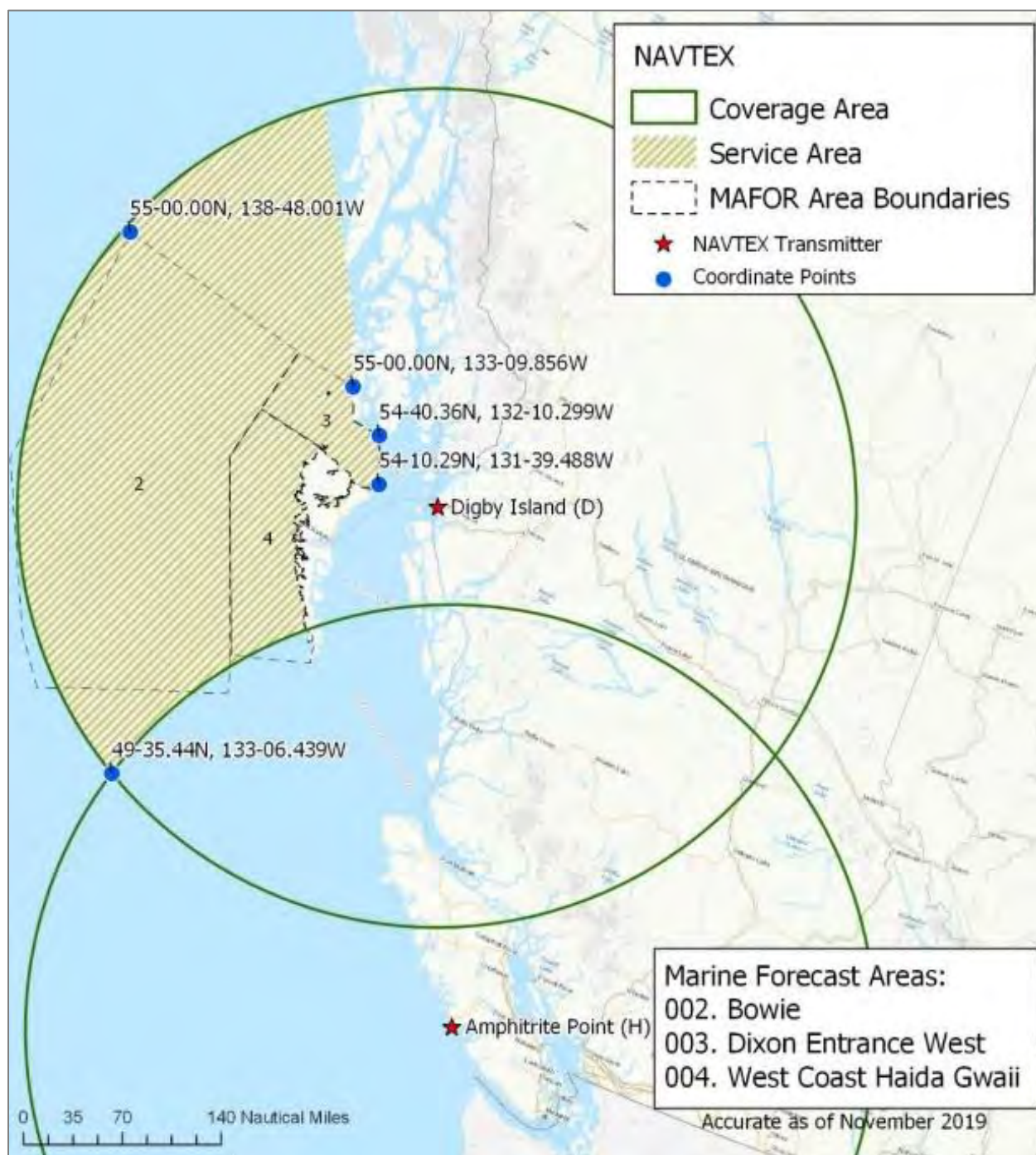

Figure 15 - Digby Island NAVTEX transmitter range [45]

6.4 Weather Forecasts

Marine weather along the marine route is available from these sources:

- ECCC website dedicated to marine weather for the North Coast [35]
- The PRPA website for live weather data [50]
- The PRPA Port Information Guide [51]
- Sailing Directions provided by the CHS [17] [16] [11]

MCTS broadcasts (see Section 6.3.1) include weather forecasts from Environment and Climate Change Canada's Marine Weather Services, including regular forecasts (one to two days), extended forecast (three to five days), technical marine synopsis, marine weather statement, wave height forecast and NAVTEX forecast.

The network of reporting stations and equipment relevant to the route is shown in Figure 16.

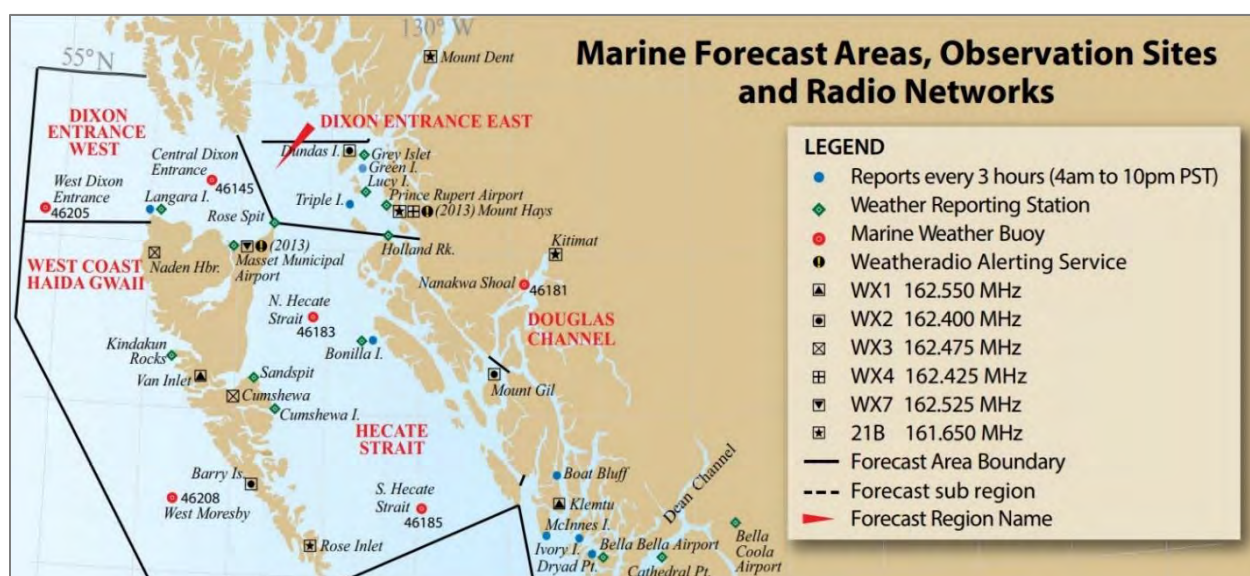

Figure 16 - North Coast marine forecast areas, observation sites and radio network [52]

7 Tug Specifications

Berthing tugs at the marine terminal will assist LNG carriers and NGL product vessels with berthing and deberthing at the marine terminal. At least one tug will be on standby during marine terminal loading operations. The location where tugs are based will be determined during detailed project planning.

If required, LNG carriers and NGL product vessels will be accompanied by an escort tug, where necessary, between the Triple Island pilot boarding station and the marine terminal. Escort tug requirements will be determined during the NRA with participation from the PPA and BCCP.

LNG carriers and NGL product vessels will comply with PPA industry notices [53] and tug requirements for the North Coast. The Project will provide tug specifications, berthing procedures, and marine terminal operating limits to Transport Canada, the PPA and BCCP six months before the start of Project operations [4]. Preliminary marine terminal operating limits are provided in the *Marine Terminal Plans and Cargo Transfer Report* [54].

8 Vessel Underkeel Clearance

Underkeel clearance is the measurement between the lowest point of the vessel and the seabed. The underkeel clearance, at lowest astronomical tide level, is determined using the vessel's draft subtracted from the charted depths along the marine route. Vessel operators make allowances to account for the potential effects of the accuracy of charts, vessel trim, vessel motions due to waves, the dynamic effect of the ship moving through the water, sagging, and hogging of the vessel, and water salinity variations that will result in draft and trim changes.

Along the marine route, the shallowest depth is 29 m. For the entire marine route, the underkeel clearance (UKC) is greater than 60 m to 100 m except for a section where depths range from 60 to 29 m that is less than 2 km in length near Hanmer Rocks in Brown Passage.

Pilots and LNG carrier operators typically use 10% of draft or 1.5 m as a minimal UKC. For the largest design vessel, this equals a depth not less than 13.75 m to 14 m. Guidance in previous TERMPOL codes [55] recommended that the minimum underkeel clearance in sheltered waters should not be less than 15% of draft (after considering squat and other factors), unless supported by explicit operational details and calculations. For the design LNG carriers [1] this equals a depth not less than 14.4 m.

Vessels in the open ocean in long period waves can experience dynamic motions up to half to two times the significant wave height [56]. For the marine route these motions would be approximately 3.5 m to 14 m (i.e., based on a significant wave height of 7.3 m, see Section 4.5). Adding this allowance to the draft of the largest design vessel would result in a UKC of 26.5 m, which is still less than the minimum charted depth along the marine route, even with additional safety factors applied. From Triple Islands to the marine terminal, wave periods are short, and waves are not forecast to have a significant effect on the dynamic motions of the design vessels.

There are no restrictions for maximum size vessels calling at the Port of Prince Rupert [57]. The approaches to the Port of Prince Rupert are safely transited by large vessels with drafts deeper than the largest design LNG carrier. For 2021 the record of vessels calling at Prince Rupert shows approximately 15% of movements were by vessels with drafts deeper than 14.5 m, with the deepest being the Bulk Carrier SM Tiger with a draft of 18.71 m [58].

Based on the above information and a review of CHS charts for the marine route, the depths along the marine route provide sufficient underkeel clearance for the design LNG carriers and NGL product vessels.

9 Anchorages

This section describes anchorages and possible places of refuge along the marine route. LNG carriers and NGL product tankers will not anchor as part of normal operations. Delays will be managed through the timing of departure from the marine terminal, arrival at the pilot boarding station, or modifying transit speed. Past studies have recommended these guidelines for large vessel anchorages [55]:

- Anchorages and emergency containment areas should be located close to the routes they serve
- The sea bottom in anchorage areas should provide good holding ground
- The water depth should not be less than the maximum draft of the vessel plus 15% (14.4 m for the carriers) and not more than 100 m
- The radius of each anchorage berth should be not less than one-half nautical mile or 925 m

9.1 Dixon Entrance

There anchorages are found north of Haida Gwaii in Dixon Entrance:

- Egeria Bay
- Virago Sound
- McIntyre Bay

All locations provide anchorage for small vessels (see *PAC 206 Hecate Strait, Dixon Entrance, Portland Inlet and Adjacent Waters and Haida Gwaii* [16]) and possible places of refuge for larger vessels to 350 m length. Anchorage information from *Places of Refuge Contingency Plan, Pacific Region (PORCP-PAC)* [59] is in Figure 13 and Table 14.

McIntyre Bay may be used when adverse weather delays pilot boarding at the Triple Island pilot boarding station. PPA Notice to Industry number 09/2015 [60] with respect to anchorage at McIntyre Bay, informs vessels they need permission from the PPA to anchor.



Figure 17 - Dixon Entrance anchorages or possible places of refuge

Table 13 - Dixon Entrance anchorages or possible places of refuge

Site Name	Egeria Bay	Virago Sound	McIntyre Bay
Site Code	DE-1	DE-2	DE-3
Location (Lat./Long-)	54°12.7' N / 132°56.1' W	54°08.8' N / 132°29.9' W	54°09.4' N / 131°55.3' W
Presence of Pilot	required	required	required
Maximum Vessel Size	up to 350 metres	up to 350 metres	up to 350 metres
Swing Room	1300 metres	1300 metres	1300 metres
Minimum Water Depth (in swing area)	40 metres	55 metres	45 metres
Maximum Water Depth (in swing area)	80 metres	65 metres	75 metres
Maximum Vessel Draft (excluding height of tide and under normal weather conditions)	18 metres	18 metres	18 metres
Bottom Type / holding ground	Rocks.	Sand	Sand, Shells
Shelter Provided	Langara and Graham Islands provide shelter from S, SW and westerly swell and winds.	Graham Islands provides shelter from S and westerly swell.	Graham Island provides some shelter from southerly swell. Southeast winds from Hecate Strait flow across low- lying Rose Spit and affect areas around McIntyre Bay.
Tides and Currents	Tide ranges from chart datum to 5.20 metres above datum. Tidal streams E to SW up to 1.5 Kts.	Tidal ranges from 0.1 metre below datum to 3.50 metres above datum. Tidal streams E to W up to 2.0 Kts.	Tidal ranges from 0.1 metre below datum to 3.50 metres above datum. Tidal streams E to W up to 2.0 Kts.

Site Name	Egeria Bay	Virago Sound	McIntyre Bay
Hazards	Tidal rips and rocks off East Langara Island.	Offshore reefs and rocks at Virago Sound.	Rose spit. Waves break close to shore during heavy swell.
Navigational Aids	Langara Pt. light / Lucy Island light	Shag Rock light / Wiah Pt. light	Rose Pt. (Ra) / Striae Island light / Wiah Pt. light
Other Considerations	Rocky bottom is not considered great holding ground.	This is an open site with limited navigational hazards and an open approach. Under certain circumstances the pilot requirement may be waived.	This is an open site with limited navigational hazards and an open approach. Under certain circumstances the pilot requirement may be waived.

9.2 Chatham Sound

Whitesand Island anchorage is located off the east coast of Dundas Island (see Figure 18). During periods of westerly winds, sheltered anchorage is available in-water depths of 30 to 50 m.

Melville Island anchorage is the area between the eastern side of Melville Island and Hammond Rocks (see Figure 18). The anchorage has a charted depth of 35 m and can provide shelter from westerly winds.

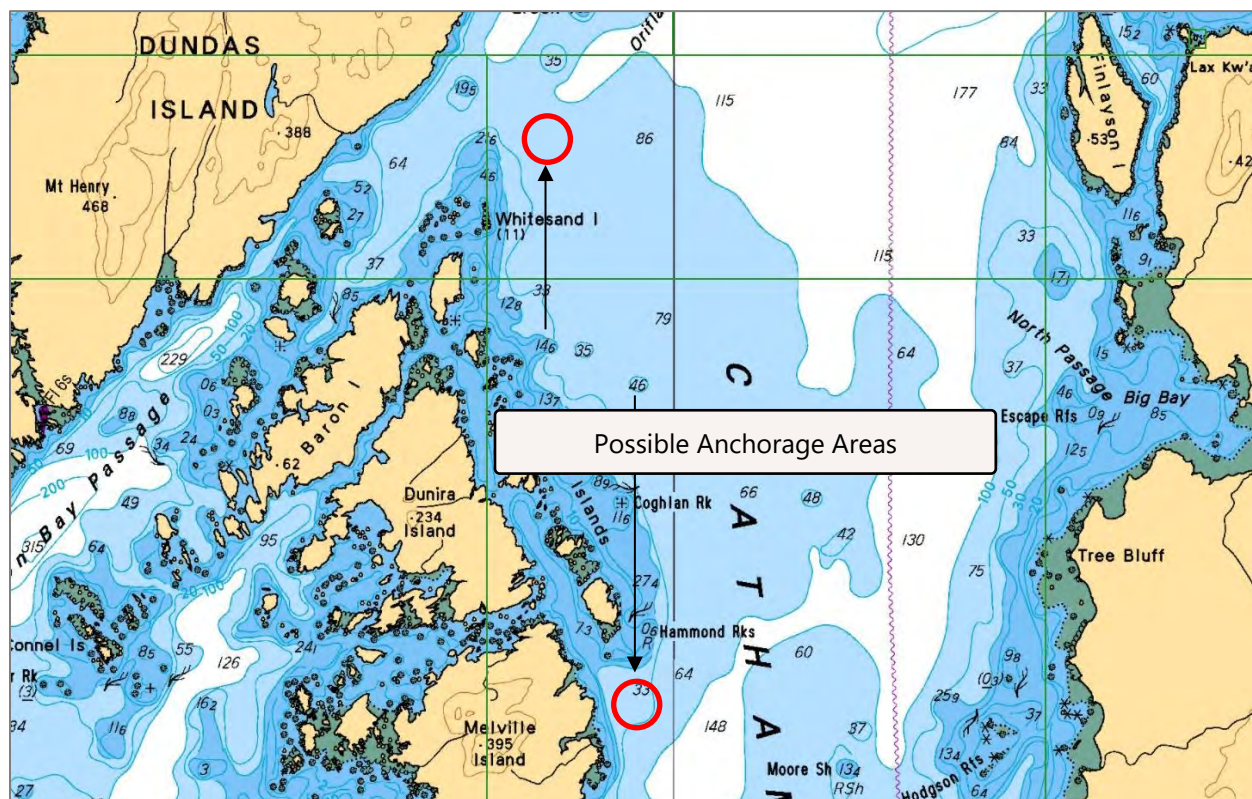

Figure 18 – Chatham Sound emergency anchorage areas (CHS Chart 3800, depths in metres to chart datum)

9.3 Portland Inlet

Port Simpson is accessed through Inskip Passage and is a deep sheltered harbour measuring approximately 2 km wide by 4 km long. CHS Chart 3959 shows three anchorages, two of which would meet the dimensional requirements for anchorage of the design LNG carriers.

The availability of Port Simpson anchorages would need to be considered relative to use by other vessels and the proximity to the nearby community of Lax Kw'alaams.

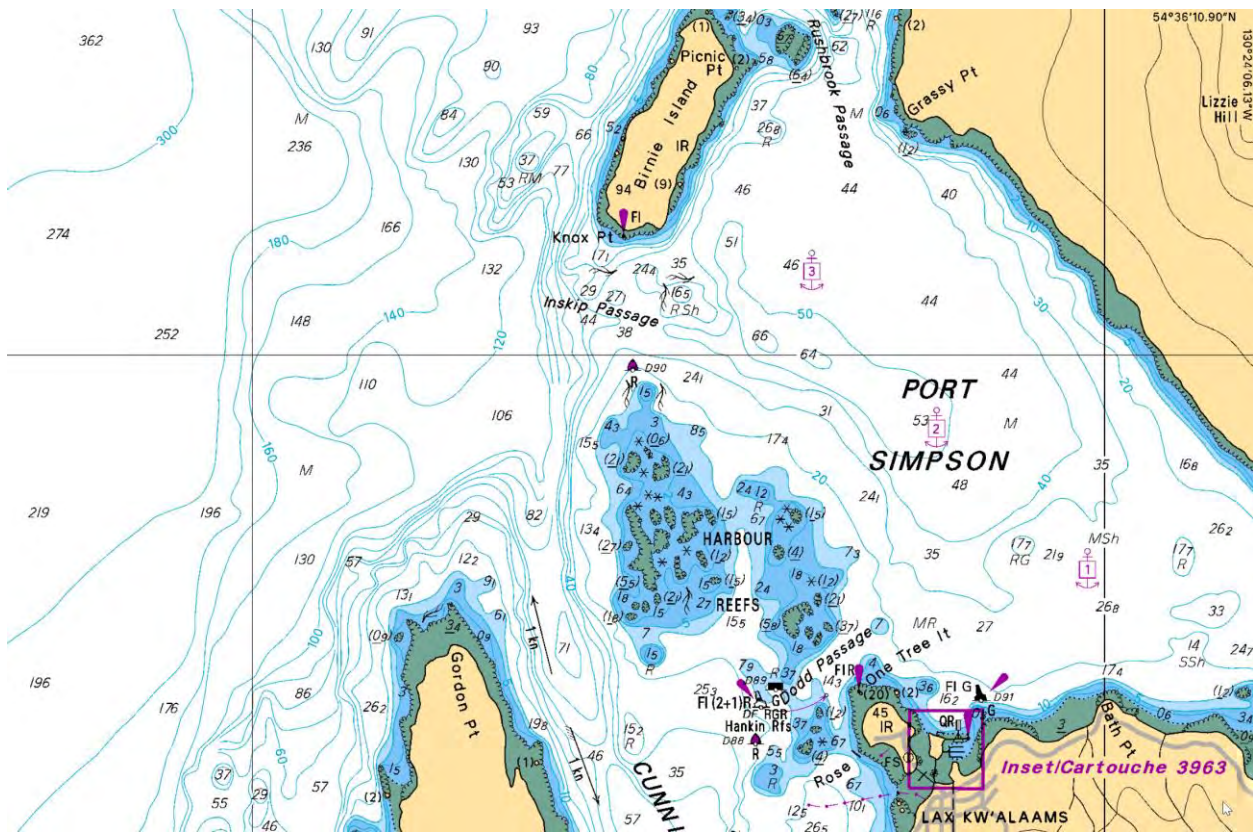

Figure 19 - Port Simpson anchorages or possible places of refuge (CHS Chart 3959, depths in metres to chart datum)

Nasoga Gulf lies between the south end of Mylor Peninsula and the mainland. Anchorage can be obtained near the head of the gulf, about 0.2 mile from the north shore, in 18 to 33 m, gravel bottom [16].

9.4 Port of Prince Rupert

The PRPA has 31 defined anchorage areas [57]. Anchorages 9, 10, 24, 30 and 31 have been identified as meeting TERMPOL guideline's swing radius recommendation of 925 metres [55] to accommodate the largest design LNG carriers [6]. Anchorage 9 and 10 are at Ridley Island (Chart 3956/3958), and anchorages 24, 30 and 31 are at Stephens Island (Chart 3956).

Table in 7.14 of the PRPA's Port Information Guide [51] lists anchorages 10, 24, 25, 30, and 31 approved for "LPG and LNG", and anchorage 27 approved for "LPG" (liquefied propane gas [LPG] ships are smaller than LNG carriers and do not need the same size swing radius).

All anchorages are on seabed which can result in poor holding. There are provisions for vessels anchoring in winter, from October 1 to March 31.

Vessels over 50 m in length must obtain permission from PRPA before anchoring.

9.5 Other Anchorages

Smaller anchorages unsuitable for LNG carriers and NGL product vessels include:

- Qlawdzeet Anchorage (north end of Stephens Island) [16]
- Haycock Island / Big Bay [11]

- Otter Anchorage (south of Finlayson Island) [16]
- Emma Point and Union Inlet [16]
- Manzanita Cove (Wales Island)
- Kumeon Bay (Steamer Passage)
- Naas Bay / Iceberg Bay
- North of Nass Point in Observatory Inlet

9.6 Holding Areas

A vessel holding area is an area considered suitable for the carriers to slowly circle under their own power or be held in position, without anchoring, using tugs. Holding areas could be utilized in the event of an unexpected delay. The following are possible holding areas:

- Naas Bay / Iceberg Bay
- Portland Inlet / Portland Canal
- Chatham Sound

Proximity to Gingolx, usage of Naas Bay as an aerodrome, and shallow, shifting sandbanks mean Naas Bay would be considered only in an emergency and if conditions made other areas unsuitable.

10 Desktop Simulation

10.1 Simulation Objectives

The *Summary Report of Desktop Simulation* has been completed by LANTEC Marine Inc. (LANTEC) to confirm the marine route can be safely navigated by the design LNG carriers and NGL product vessels. The *Summary Report of Desktop Simulation* is attached in Appendix A.

The objectives of the *Summary Report of Desktop Simulation* are to:

- Confirm the marine route can be safely navigated by the design LNG carriers and NGL product vessels
- Assess the factors influencing vessel manoeuvrability (e.g., LNG carrier and NGL product vessel size, loaded or ballasted condition, speed, channel dimensions, wind speed, currents, etc.)
- Estimate critical conditions for manoeuvres along the marine route, including the upper limit of metocean conditions where carriers can safely transit unassisted by tugs
- Make recommendations for the NRA to be completed during detailed project planning with the participation of the PPA and BCCP

Berthing at the marine terminal will be assessed as part of future FMBS and the NRA.

10.2 Methodology

The desktop navigation simulation was conducted using a Kongsberg Desktop Simulator with the K-Sim Ship Bridge Simulator software. The core software system, area database and environmental models has been used for other projects in the region and is the same system found at the full mission bridge simulator operated by the PPA and BCCP.

The desktop simulator has the same fidelity and accuracy as a full mission simulator and encompasses both hydrodynamic (i.e., vessel motion) and physical simulation (i.e., vessel and physical object interaction). The primary differences are the control systems for the simulated ships, and human participation. With the desktop system, all aspects of the simulation and ship control mechanisms are controlled by one computer with a single user interface for the test director. This contrasts with the immersive full mission ship and tug simulator, where a real pilot with real controls and radio devices controls the ship and coordinates tug activity as required.

Due to the reduced time and staffing required for each run, and the ability to run parts of the simulation at faster than real-time speeds, desktop simulation is well suited to an initial navigational assessment considering a broad range of situations and environmental conditions. The findings of the desktop simulation can be used to inform future FMBS and the scope and extent of the NRA.

10.3 Findings and Recommendations

The marine route is feasible for the regular movements of LNG carriers with capacities to 217,000 m³. The most constrained portion of the marine route is Brown Passage, which is transited by bulk carriers and container ships, many of which are much bigger and more deeply laden than an LNG carrier.

Steering and positional control of the design vessels is good up to a sustained wind speed of 30 kn with a transit speed of 10 kn or less. For greater wind speeds, steering and positional control reduces. However, simulations show that the route can be safely transited, without tug assistance, with wind speeds of up to 40 kts in open water and 50 kts in the fjords, albeit with more deviation from the course and with more exaggerated steering inputs required.

Most of the marine route is deep and exceeds 2.8 km in width. Transits may be performed at any time of the day, and during any state of tide. This follows the existing policy in place on the North Coast for LPG carriers, bulk carriers, and container ships.

Given the dimensions of the channels and the relatively low traffic volumes, two-way traffic is feasible throughout the marine route. This should be confirmed during FMBS and the NRA with a focus on the governing segment of the route in Brown Passage, between Triple Island and Hanmer Rocks.

References

- [1] Westmar Advisors Inc., "Vessel Specifications," 1220197-P01-24-RPT-0001, 2023.
- [2] Department of Fisheries and Oceans, "Vertical datum chart references." Accessed: Oct. 02, 2022. [Online]. Available: <https://tides.gc.ca/en/vertical-datum-chart-references>
- [3] K-J Millar, "Record-breaking vessel berths in Prince Rupert," Prince Rupert Northern View. Accessed: Sep. 28, 2022. [Online]. Available: <https://www.thenorthernview.com/news/record-breaking-vessel-berths-in-prince-rupert/>
- [4] Transport Canada, "TERMPOL Review Process Report on the LNG CANADA Project," Jul. 2022. Accessed: Jul. 28, 2022. [Online]. Available: <https://publications.gc.ca/site/fra/9.808172/publication.html>
- [5] Transport Canada, Ed., *The TERMPOL Co-ordinating Committee's Assessment Report on Dome Petroleum Limited's Proposal to Construct and Operate a Liquefied Natural Gas Marine Terminal at Grassy Point*. Vancouver, B.C: Department of Fisheries and Oceans, 1977. Accessed: Aug. 01, 2022. [Online]. Available: <https://vpl.bibliocommons.com/v2/record/S38C334932>
- [6] Transport Canada, "TERMPOL Review Process Report on the Pacific Northwest LNG Project." Apr. 2017. Accessed: Jul. 29, 2022. [Online]. Available: <https://www.iaac-aeic.gc.ca/050/evaluations/proj/80032?culture=en-CA>
- [7] Westmar Advisors Inc., "Casualty Data and Risk Analysis," 1220197-P01-23-RPT-0001, 2023.
- [8] Westmar Advisors Inc., "Marine Traffic," 1220197-P01-21-RPT-0001, 2023.
- [9] *SOR/2000-132 | General Pilotage Regulations*. CanLII. Accessed: Jul. 26, 2023. [Online]. Available: <https://www.canlii.org/en/ca/laws/regu/sor-2000-132/197674/sor-2000-132.html>
- [10] *RSC 1985, c P-14 | Pilotage Act*. CanLII. Accessed: Jul. 26, 2023. [Online]. Available: <https://www.canlii.org/en/ca/laws/stat/rsc-1985-c-p-14/210587/rsc-1985-c-p-14.html>
- [11] Canadian Hydrographic Service, "Canadian Sailing Directions: Inner Passage - Queen Charlotte Sound to Chatham Sound." Department of Fisheries and Oceans, Dec. 2021. Accessed: Jul. 29, 2022. [Online]. Available: <https://waves-vagues.dfo-mpo.gc.ca/Library/chs-shc-PAC205-eng-202206-41060325.pdf>
- [12] Permanent International Association of National Congresses, International Association of Ports and Harbors, International Maritime Pilots Association, and International Association of Lighthouse Authorities, "Approach Channels: A Guide for Design." PIANC, 1999. Accessed: Sep. 14, 2022. [Online]. Available: https://books.google.ca/books?id=yMIhRGgN7qsC&printsec=frontcover&source=gbs_ge_summary_r&cad=0#v=onepage&q&f=false
- [13] Russ Klock and John Mullock, "The Weather of British Columbia: Graphic Area Forecast 31," NAV CANADA. Accessed: Aug. 15, 2022. [Online]. Available: <https://www.navcanada.ca/en/lawm-bc-en.pdf>
- [14] Richard E. Thomson, *Oceanography of the British Columbia Coast*. in Canadian special publication of fisheries and aquatic sciences, no. 56. Ottawa: Dept. of Fisheries and Oceans, 1981. Accessed: Aug. 07, 2022. [Online]. Available: <https://publications.gc.ca/site/fra/9.816310/publication.html>
- [15] Environment and Climate Change Canada, "Historic Weather Data for the Port of Prince Rupert." Accessed: Aug. 25, 2022. [Online]. Available: https://climate.weather.gc.ca/historical_data/search_historic_data_e.html

- [16] Canadian Hydrographic Service, "Canadian Sailing Directions: Hecate Strait, Dixon Entrance, Portland Inlet and Adjacent Waters and Haida Gwaii." Department of Fisheries and Oceans, Jun. 2022. Accessed: Jul. 15, 2022. [Online]. Available: <https://waves-vagues.dfo-mpo.gc.ca/Library/chs-shc-PAC206-eng-202206-41060337.pdf>
- [17] Canadian Hydrographic Service, "Canadian Sailing Directions: General Information Pacific Coast." Department of Fisheries and Oceans, Dec. 2021. Accessed: Sep. 02, 2022. [Online]. Available: <https://waves-vagues.dfo-mpo.gc.ca/library-bibliotheque/chs-shc-sdPAC200-eng-202112-4104826x.pdf>
- [18] CWA Engineers, "Stewart World Port - Berthing Arrangement 1." Stewart World Port, Jun. 02, 2015. Accessed: Oct. 01, 2022. [Online]. Available: <https://stewartworldport.com/wp-content/uploads/Stewart-World-Port-Berthing-Arrangement-1.pdf>
- [19] Aurora LNG, "Hydrodynamic Modelling of Changes in Sediment Erosion and Accretion due to Project Infrastructure," Nov. 2016. Accessed: Aug. 30, 2022. [Online]. Available: <https://projects.eao.gov.bc.ca/p/588511eeaaecd9001b828062/project-details>
- [20] Westmar Advisors Inc., "Metocean Study," 1210142-P02-RPT-0001, May 2022.
- [21] Environment and Climate Change Canada, "Canadian marine warning program: chapter 1." Accessed: Oct. 02, 2022. [Online]. Available: <https://www.canada.ca/en/environment-climate-change/services/general-marine-weather-information/publications/canadian-warning-program/chapter-1.html>
- [22] Transport Canada, "TERMPOL Review Process Report on the KITIMAT LNG Project," 1977. Accessed: Aug. 10, 2022. [Online]. Available: <https://tc.canada.ca/en/marine-transportation/marine-safety/tp-15385-term-pol-review-process-kitimat-lng-project>
- [23] Canadian Hydrographic Service, "Tide and Current Tables: Queen Charlotte Sound to Dixon Entrance." Department of Fisheries and Oceans, 2022. Accessed: Aug. 19, 2022. [Online]. Available: <https://waves-vagues.dfo-mpo.gc.ca/library-bibliotheque/chs-shc-tct-tmc-vol7-2022-41052584.pdf>
- [24] Westmar Advisors Inc., "Terminal Operations Manual," 1220197-P01-27-RPT-0001, 2023.
- [25] Department of Fisheries and Oceans, "Tides, Currents, and Water levels." Accessed: Oct. 02, 2022. [Online]. Available: <https://tides.gc.ca/en/tides-currents-and-water-levels>
- [26] Kevin Obermeyer, "Letter of Comment of the Pacific Pilotage Authority to the Enbridge Northern Gateway Project Joint Review Panel," Aug. 28, 2012. Accessed: Nov. 16, 2022. [Online]. Available: <https://apps.cer-rec.gc.ca/REGDOCS/File/Download/861982>
- [27] Pacific Pilotage Authority, "Compulsory Pilotage Areas," Pacific Pilotage Authority. Accessed: Aug. 17, 2022. [Online]. Available: <https://ppa.gc.ca/compulsory-pilotage-areas>
- [28] Pacific Pilotage Authority, "Notice to Industry: Pilot Transfers by Helicopter on the North Coast." Accessed: Oct. 02, 2022. [Online]. Available: https://ppa.gc.ca/standard/pilotage/2018-07/Notice%20to%20Industry%20Rupert%20Helicopter%20Final%20Nov2015_0.pdf
- [29] "Vessel Movement Data | Pacific Pilotage Authority." Accessed: Aug. 24, 2022. [Online]. Available: <https://ppa.gc.ca/vessel-movement-data>
- [30] Ksi Lisims LNG, "Ksi Lisims LNG Detailed Project Description," BC Environmental Assessment Office, 2022, p. 680. Accessed: Aug. 15, 2022. [Online]. Available: <https://www.projects.eao.gov.bc.ca/p/60edc23bc69c5e0023a12539/project-details>
- [31] Department of Fisheries and Oceans, "Nautical charts." Accessed: Oct. 02, 2022. [Online]. Available: <https://www.charts.gc.ca/charts-cartes/index-eng.html>

- [32] Department of Fisheries and Oceans, "Canadian Sailing Directions." Accessed: Oct. 02, 2022. [Online]. Available: <https://charts.gc.ca/publications/sailingdirections-instructionsnautiques-eng.html>
- [33] Canadian Coast Guard, "Canadian Coast Guard - Notices to Mariners - NOTMAR." Accessed: Oct. 02, 2022. [Online]. Available: <https://www.notmar.gc.ca/index-en.php>
- [34] Canadian Coast Guard, "Navigational Warnings." Accessed: Oct. 02, 2022. [Online]. Available: <https://www.marinfo.gc.ca/en/Avis/index.asp>
- [35] Environment and Climate Change Canada, "Marine Weather for: Pacific - North Coast." Accessed: Oct. 01, 2022. [Online]. Available: https://weather.gc.ca/marine/region_e.html?mapID=01
- [36] Canadian Coast Guard, "Pacific Coast List of Lights, Buoys and Fog Signals." Nov. 2011. Accessed: Aug. 11, 2022. [Online]. Available: <https://www.notmar.gc.ca/list-lights>
- [37] Canadian Coast Guard, "Marine Communications and Traffic Services program information." Accessed: Sep. 21, 2022. [Online]. Available: <https://www.ccg-gcc.gc.ca/mcts-sctm/program-info-programme-eng.html>
- [38] Canadian Coast Guard, "CCG e-Nav - AIS." Accessed: Oct. 02, 2022. [Online]. Available: <https://e-navigation.canada.ca/topics/traffic/docs/ais/ships>
- [39] Canadian Coast Guard, *The Canadian Aids to Navigation System*, 2011 ed. Ottawa: Department of Fisheries and Oceans, 2012. Accessed: Aug. 19, 2022. [Online]. Available: <https://central.bac-lac.gc.ca/.item?id=T31-29-2012-eng&op=pdf&app=Library>
- [40] Canadian Coast Guard, "Canadian Coast Guard Aids to Navigation Program." Accessed: Sep. 15, 2022. [Online]. Available: <https://www.ccg-gcc.gc.ca/navigation/aids-aides/program-info-programme-eng.html>
- [41] Canadian Coast Guard, "Levels of Service." Accessed: Oct. 06, 2022. [Online]. Available: <https://www.ccg-gcc.gc.ca/publications/corporation-information-organisation/levels-of-service-niveaux-de-service/page04-eng.html>
- [42] *SOR/2020-216 | Navigation Safety Regulations, 2020*. CanLII. Accessed: Jul. 26, 2023. [Online]. Available: <https://www.canlii.org/en/ca/laws/regu/sor-2020-216/213728/sor-2020-216.html>
- [43] *SC 2001, c 26 | Canada Shipping Act, 2001*. CanLII. Accessed: Jul. 26, 2023. [Online]. Available: <https://www.canlii.org/en/ca/laws/stat/sc-2001-c-26/160998/sc-2001-c-26.html>
- [44] Canadian Coast Guard, "Notices to Mariners 1 to 46, Annual Edition 2023." Canadian Coast Guard. Accessed: Aug. 05, 2023. [Online]. Available: https://publications.gc.ca/collections/collection_2023/mpo-dfo/Fs151-4-2023-eng.pdf
- [45] Canadian Coast Guard, "Radio Aids to Marine Navigation 2023." 2023.
- [46] Fisheries and Oceans Canada, "Moving towards Electronic Navigational Charts for safer navigation." Accessed: Oct. 07, 2022. [Online]. Available: <https://www.charts.gc.ca/help-aide/annoncements-annonces/2021/2021-07-19a-eng.html>
- [47] *SOR/89-98 | Vessel Traffic Services Zones Regulations*. CanLII. Accessed: Jul. 26, 2023. [Online]. Available: <https://www.canlii.org/en/ca/laws/regu/sor-89-98/93891/sor-89-98.html>
- [48] *SOR/2004-144 | Marine Transportation Security Regulations*. CanLII. Accessed: Jul. 26, 2023. [Online]. Available: <https://www.canlii.org/en/ca/laws/regu/sor-2004-144/112853/sor-2004-144.html>
- [49] FreightWaves, "Port of Prince Rupert invests in navigational projects," American Shipper. Accessed: Oct. 07, 2022. [Online]. Available: <https://www.freightwaves.com/news/port-of-prince-rupert-invests-in-navigational-projects>

- [50] Prince Rupert Port Authority, "Live Harbour Data." Accessed: Oct. 01, 2022. [Online]. Available: <https://www.rupertport.com/live-harbour-data/>
- [51] Prince Rupert Port Authority, "Port Information Guide." Jan. 17, 2022. Accessed: Sep. 18, 2022. [Online]. Available: <https://www.rupertport.com/port-information-guide/>
- [52] Environment and Climate Change Canada, *Marine weather guide: Environment Canada's marine weather services for the Pacific Coast*. Environment Canada, 2013. Accessed: Aug. 15, 2022. [Online]. Available: http://epe.lac-bac.gc.ca/100/201/301/weekly_checklist/2014/full_list/w14-07-F-E.html/collections/collection_2014/ec/En56-233-2013-eng.pdf
- [53] Pacific Pilotage Authority, "Publications & Industry Notices." Accessed: Oct. 07, 2022. [Online]. Available: <https://ppa.gc.ca/Publications%20%26%20Industry%20Notices>
- [54] Westmar Advisors Inc., "Terminal Plans and Cargo Transfer," 1220197-P01-25-RPT-0001, 2023.
- [55] Transport Canada, "TERMPOL Review Process – 2019 Edition – TP 743 E," Sep. 2019. Accessed: Aug. 18, 2022. [Online]. Available: <https://tc.canada.ca/en/marine-transportation/marine-safety/termpol-review-process-2019-edition-tp-743-e>
- [56] Permanent International Association of National Congresses, "Underkeel Clearance for Large Ships in Maritime Fairways with Hard Bottom." Accessed: Oct. 07, 2022. [Online]. Available: <http://graduadosportuaria.com.ar/Vias%20Navegables/PIANC%20Underkeel%20clearance.pdf>
- [57] Prince Rupert Port Authority, "Prince Rupert Port Guide," PRPA. Accessed: Aug. 17, 2022. [Online]. Available: <https://www.rupertport.com/wp-content/uploads/2021/12/PIG-Port-Information-Guide-2022-Final-8-Dec-21-1.pdf>
- [58] Pacific Pilotage Authority, "Vessel Movement Data." Accessed: Aug. 24, 2022. [Online]. Available: <https://ppa.gc.ca/vessel-movement-data>
- [59] Environment and Climate Change Canada *et al.*, "Response to Information Request of Cowichan Tribes," Transport Canada, Nov. 2017. Accessed: Aug. 26, 2022. [Online]. Available: <https://apps.cer-rec.gc.ca/REGDOCS/File/Download/3745475>
- [60] Pacific Pilotage Authority, "Notice to Industry: Anchoring in McIntyre Bay - Haida Gwaii." Accessed: Sep. 02, 2022. [Online]. Available: https://ppa.gc.ca/standard/pilotage/2018-07/Notice%20to%20Industry_2015-09_Anchoring%20in%20McIntyre%20Bay_0.pdf

Appendix A

Desktop Navigation Simulation Study



Summary Report of Desktop Simulation

Ksi Lisims LNG Project

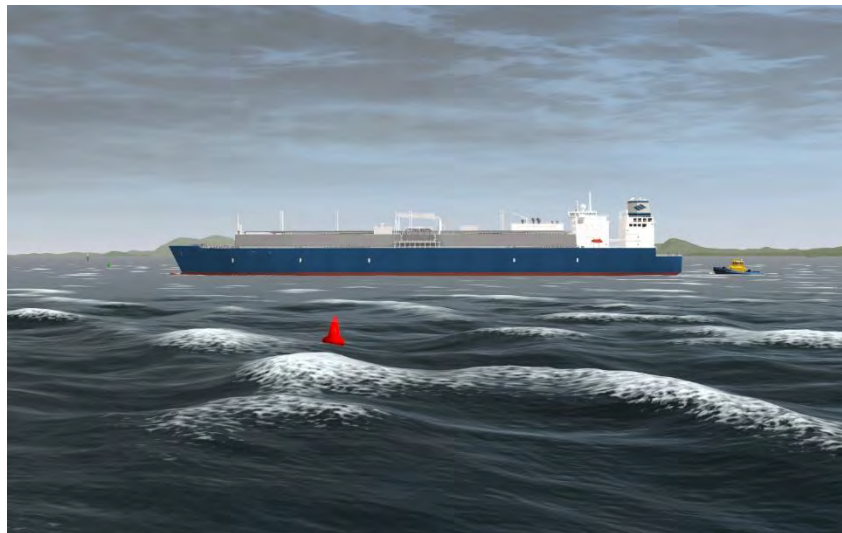

Marine Route Analysis

11 October 2023

Prepared By:



Executive Summary

The Nisga'a Nation, Rockies LNG Limited Partnership (Rockies LNG) and Western LNG LLC (via its subsidiary, Western LNG ULC) are proposing to jointly develop the Ksi Lisims LNG - Natural Gas Liquefaction and Marine Terminal Project (the Project). The Project includes a floating natural gas liquefaction facility and marine terminal at Wil Milit on the north coast of British Columbia (North Coast) at the northern end of Pearse Island. The marine terminal site (Site) is approximately 15 kilometres west of the Nisga'a community of Gingolx.

Westmar Advisors Inc. (Westmar) has been retained to complete a navigation safety assessment (NSA). The NSA is part of the Project's application for an Environmental Assessment Certificate (the Application). This simulation analysis (the Study) was undertaken as part of the NSA and was conducted by LANTEC Marine Inc. (LANTEC) on behalf of Westmar. Additional navigation simulations will be completed before the start of operations and will be the subject of approval conditions.

The marine route selected for the Project, from open ocean to the Triple Island Pilot Boarding Station and through compulsory pilotage waters to the Site in Portland Canal, has been in use for many years by commercial vessels. The British Columbia Coast Pilots Ltd. (BCCP) are familiar with the marine route, and annually guide hundreds of similar-sized vessels through the western portion of the marine route to the Port of Prince Rupert. The voyage segment between the pilot station and Lucy Islands is frequented by LPG carriers proceeding to and from the Trigon Pacific Terminals on Ridley Island and the Pembina Prince Rupert Terminal at Watson Island. The remainder of the marine route is navigated regularly by the BCCP when moving vessels to and from the Port of Stewart at the head of the Portland Canal. As the marine route is already trafficked by deep-draught vessels, this simulation has endeavoured to remain consistent with the safe navigation movements, procedures and rules that have already been established for the North Coast, with a focus on assessing the unique characteristics of LNG carriers and their operational limits.

The Study was conducted by LANTEC using a Kongsberg Desktop Simulator with the K-Sim Ship Bridge Simulator software. The core software system, area database and environmental models are identical to those used for numerous other simulation analysis for projects in BC and globally (both desktop and manned) and is completely compatible with the PSTAR simulator in Vancouver owned by the Pacific Pilotage Authority (PPA) and the BCCP.

As a planning and due diligence exercise, the Study needed to address macro items that could apply over the entire life of the Project. Design LNG carriers for the Project range from approximately 140,000 m³ to of 217,000 m³ capacity. LNG carriers calling at the marine terminal are not forecast to exceed approximately 180,000 m³ capacity. The two floating liquefaction, storage, and off-loading barges (FLNGs) can receive LNG carriers up to 217,000 m³ capacity (315 m x 50 m x 12.0 m). From the perspective of assessing the marine route from an overall navigational, ship steering / positional control and emergency response capabilities, it was determined that the most prudent action would be to conduct an initial overall assessment and validation of navigational risk by using the 217,000 m³ LNG carrier as the reference benchmark. In this manner, it could be determined if the marine route was feasible for all LNG carriers up to 217,000 m³ capacity and to identify any areas where either navigational constraints or environmental variables

create situations that might require unique or specific risk mitigation measures. The goal of the Study was to assess navigational risk under operational conditions for LNG carriers up to 217,000 m³ capacity and to assess the feasibility of the marine route to be used on a regular basis over the life cycle of the Project.

The Study is one of the first steps leading to a formalized BCCP / PPA NRA process. This report does not attempt to identify detailed operating procedures for manoeuvres near the terminal, to establish tug requirements, or to assess extreme risk events and contingency planning in detail. These aspects will be determined as part of the joint BCCP / PPA Navigational Risk Assessment (NRA) process which includes convening a Risk Assessment Committee and conducting full mission bridge simulation (FMBS).

The Study has determined that the marine route is feasible for the regular movements of LNG carrier ships up to 217,000m³ capacity, with suitable risk mitigation measures.

Transiting at lower speeds is the governing case as steering control reduces with water speed. Simulations show that a minimum transit speed of 10 knots still provides a very good level of steering control in wind speeds up to 30 knots from the stern quadrant, and up to 40 knots with winds from the bow quadrant. This speed additionally minimizes sound and risk to marine mammals.

Consistent with real-world operations and practises, and the handling characteristics of LNG carriers, this analysis has demonstrated that under day-to day operating conditions, without tug assistance, the steering and positional control of vessels ranging in size from 145,000 m³ (285 metres LOA) to 217,000 m³ (315 metres LOA) is very good up to a sustained wind speed of 30 knots with a transit speed of 10 knots or less.

At greater wind speeds, steering and positional control begins to reduce. However, simulations show that the marine route can be safely transited, without tug assistance, with wind speeds of up to 40kts in open water and 50kts in the fjords, albeit with more deviation from the course and with more exaggerated steering inputs required.

When wind speeds exceed 30 to 40 knots, pilot boarding may become challenging. Worldwide few LNG terminals permit docking or undocking operations when the sustained wind speed exceeds 25 to 30 knots. Delays will be managed through the timing of departure from the marine terminal, arrival at the pilot boarding station, or modifying transit speed.

For planning purposes, it is recommended that:

- Transits are not planned when sustained winds of 40 to 50 knots or more are forecasted during the approximately 6-hour transit window;
- Given that for most of the transit the channel is deep and exceeds 1.5 nautical miles in width, and that the most constrained area (the buoys at Hanmer Rocks) is over 1,000 metres wide, it is recommended that transits be performed at any time of the day, and during any state of tide. This would be consistent with existing policy in place for LPG ships, and bulk and container ships, many of which are much bigger and more deeply laden than a 217,000 m³ LNG carrier; and
- Given the width of the channel, and the relatively low volume of vessel traffic, there is ample room for vessel passing / meeting. One potential exception (during adverse

weather conditions) is the area between 1 nautical mile east of Hanmer Rocks to Triple Island when a loaded vessel is outbound. This should be tested during the FMBS.

Berthing tugs will be available for all movements to and from the facility and specific details of these requirements will be thoroughly assessed during the FMBS.

Tug requirements should be tested more thoroughly during the combined PPA / BCCP NRA process. Any policy must also be consistent with the evolving PPA requirements for escort tugs on the North Coast.

Consideration should be given to installing an aid to navigation on Moore Shoal. If physically feasible this would be an isolated buoy or alternatively a virtual aid to navigation. This can be reviewed by the CCG as part of ongoing LOS reviews.

Table of Contents

1	Overview of Simulation Study	9
1.1	Simulation System	9
1.2	Study Goals	10
1.3	Ship Models	11
1.4	Area Model	11
2	Marine Route and Metocean Conditions	12
2.1	Detailed Description – Simulation Test Route	12
2.2	Western Route Segment	13
2.3	Central Route Segment	15
2.4	Northern Route Segment	18
3	Summary of Real Time Simulation Analysis	22
3.1	Existing Operational Rules and Protocol	22
3.1.1	Marine Traffic Communication Service	22
3.1.2	Mandatory Pilotage	22
3.1.3	Tugs	22
3.1.4	Compulsory Pilotage Risk Assessment	23
3.2	Testing Methodology	23
3.3	Summary of Controlled Runs	24
4	Results and Findings	26
4.1	Steering and Positional Control: Day-to-Day Operations	26
4.2	Steering and Positional Control: Wind Limits	35
4.3	Turning Through and Holding in Extreme Wind	55
4.4	Observations on Aids to Navigation	69
5	Conclusions and Recommendations	70
5.1	Conclusions	70
5.2	Environmental Limitations	70
5.3	Transit Speeds	Error! Bookmark not defined.
5.4	Tug Requirements	71
5.5	Aids to Navigation	71
5.6	Recommendations	71
	Appendix A: Existing Procedural References	72

List of Tables

Table 1: Vessel Particulars	11
Table 2: Route Coordinates	13
Table 3: Directional Probability – Wind Direction and Speed Prince Rupert.....	15
Table 4: Directional Probability – Wind Direction and Speed Grey Islet	18
Table 5: One Year Tidal Current Statistics.....	21
Table 6: Simulated Test Runs.....	25

List of Figures

Figure 1: Site Location and Overall Marine Route	12
Figure 2: Simulator Chart Zoom View – Western Segment	14
Figure 3: CHS Tidal Graph – Prince Rupert.....	14
Figure 4: Simulator Chart Zoom View – Moore Shoal to Pearl Harbour	16
Figure 5: Simulator Chart Zoom View – Pearl Harbour to Pointer Rocks	16
Figure 6: Simulator Chart Zoom View – Pointer Rocks to Somerville Island	17
Figure 7: Simulator Chart Zoom View – Entry to Portland Inlet at Somerville Island	19
Figure 8: Simulator Chart Zoom View – Somerville Island to Lizard Point.....	19
Figure 9: Simulator Chart Zoom View – Lizard Point to Flat Island	19
Figure 10: Simulator Chart Zoom View – Flat Point to Whiskey Bay	20
Figure 11: Observed Current Velocity Percentile – Site ADCP Buoy at 10.6 m	21
Figure 12: Track-plot – Pilot Station to Triple Island (R1-1).....	27
Figure 13: Track-plot – Brown Passage to Beaver Rock (R1-1).....	27
Figure 14: Applied rudder – Pilot Station to Beaver Rock (R1-1).....	28
Figure 15: Applied rudder – Pilot Station to Beaver Rock (R1-1).....	28
Figure 16: Applied rudder – altering from 084° to 025° (R1-1).....	29
Figure 17: Heading vs course, wind on beam and quarter (R1-1)	29
Figure 18: Track-plot – altering 084° to 025 (R1-1).....	30
Figure 19: Track-plot – nearest hazard on 001° course (R1-1).....	30
Figure 20: Applied rudder – 001° course and altering to 052 (R1-1).....	31
Figure 21: Heading vs course – 40 knot crosswinds (R1-1)	31
Figure 22: Applied rudder – 052° course and altering to 029 (R1-1).....	32
Figure 23: Track-plot – entering Portland Inlet wind NE 40 (R1-1)	32
Figure 24: Track-plot – Portland Inlet altering 029° to 052 (R1-1).....	33
Figure 25: Track-plot – Portland Inlet altering 052° to 031 (R1-1).....	33
Figure 26: Track-plot – Portland Inlet altering 031° to 343 (R1-1).....	33
Figure 27: Applied rudder – altering from 029° to 343 (R1-1)	34
Figure 28: Heading and course differential on 343° course (R1-1).....	34
Figure 29: Track-plot – Beaver Rocks to Triple Island, wind SE 35 (R1-2).....	35
Figure 30: Track-plot – Passing Hanmer Rocks, wind SE 35 (R1-2).....	36
Figure 31: Rate of turn – Beaver Rocks to Triple Island, wind SE 35 (R1-2).....	36
Figure 32: Heading vs course – Beaver Rocks to Triple Island, wind SE 35 (R1-2).....	37
Figure 33: Wind vs rudder – Beaver Rocks to Triple Island, wind SE 35 (R1-2)	37
Figure 34: Rudder vs telegraph – Beaver Rocks to Triple Island, wind SE 35 (R1-2)	38
Figure 35: Track-plot – Pilot Station to Hanmer Rocks, wind NW 40 (R1-3)	39

Figure 36: Track-plot – altering 102° to 084°, wind NW 40 (R1-3)	39
Figure 37: Track-plot – Hanmer Rocks to 025° course, wind NW 40 (R1-3).....	40
Figure 38: Drift angle – inbound LNGC, wind NW 40 (R1-3)	40
Figure 39: Applied rudder – inbound LNGC, wind NW 40 (R1-3)	41
Figure 40: Rate of turn – inbound LNGC. Wind NW 40 (R1-3).....	41
Figure 41: Track-plot – 205° course to Hanmer Rocks, wind SE 40 (R1-4).....	42
Figure 42: Track-plot – outbound Goal Posts, wind SE 40 (R1-4).....	42
Figure 43: Track-plot – Hanmer Rocks to Pilot Station, wind SE 40 (R1-4).....	43
Figure 44: Drift angle – outbound LNGC, wind SE 40 (R1-4)	43
Figure 45: Applied rudder – outbound LNGC, wind SE 40 (R1-4)	44
Figure 46: Rate of turn – outbound LNGC, wind SE 40 (R1-4).....	44
Figure 47: Track-plot – Pilot Station to Hanmer Rocks, wind NW 50 (R1-5)	45
Figure 48: Track-plot – altering 102° to 084°, wind NW 50 (R1-5)	45
Figure 49: Track-plot – Hanmer Rocks to 025° course, wind NW 50 (R1-5).....	46
Figure 50: Drift angle – inbound LNGC, wind NW 50 (R1-5)	46
Figure 51: Applied rudder – inbound LNGC, wind NW 50 (R1-5)	47
Figure 52: Rate of turn – inbound LNGC, wind NW 50 (R1-5).....	47
Figure 53: Track-plot – 205° course to Hanmer Rocks, wind SE 50 (R1-6).....	48
Figure 54: Track-plot – outbound steadying 264, wind SE 50 (R1-6)	48
Figure 55: Track-plot – Hanmer Rocks to Pilot Station, wind SE 50 (R1-6).....	49
Figure 56: Drift angle – outbound LNGC, wind SE 50 (R1-6)	49
Figure 57: Applied rudder – outbound LNGC, wind SE 50 (R1-6)	50
Figure 58: Rate of turn – outbound LNGC, wind SE 40 (R1-6).....	50
Figure 59: Track-plot – Pilot Station to Hanmer Rocks, wind NW 40 (R1-7)	51
Figure 60: Track-plot – Hanmer Rocks to 025° course, wind NW 40 (R1-7).....	51
Figure 61: Drift angle – inbound NGL product vessel, wind NW 40 (R1-7).....	52
Figure 62: Applied rudder – inbound NGL product vessel, wind NW 40 (R1-7).....	52
Figure 63: Rate of turn – inbound NGL product vessel, wind NW 40 (R1-7)	53
Figure 64: Track-plot – 205° course to Hanmer Rocks, wind SE 40 (R1-8).....	53
Figure 65: Track-plot – outbound Goal Posts, wind SE 40 (R1-8).....	54
Figure 66: Drift angle – outbound NGL product vessel, wind SE 40 (R1-8).....	54
Figure 67: Applied rudder – outbound NGL product vessel, wind SE 40 (R1-8).....	55
Figure 68: Rate of turn – outbound NGL product vessel, wind SE 40 (R1-8)	55
Figure 69: Track-plot – turning stern through 50 knot winds (R1-9).....	56
Figure 70: Rate of turn – turning stern through 50 knot winds (R1-9).....	57
Figure 71: Rudder and RPM – turning stern through 50 knot winds: (R1-9).....	57
Figure 72: Track-plot – turning stern through 50 knot winds (R1-10).....	58
Figure 73: Rate of turn – turning stern through 50 knot winds (R1-10).....	58
Figure 74: Rudder and RPM – turning stern through 50 knot winds (R1-10).....	59
Figure 75: Track-plot – Hour 1, holding in 50 knot winds (R1-11).....	59
Figure 76: Rudder and RPM – Hour 1, holding in 50 knot winds (R1-11).....	59
Figure 77: Track-plot – Hour 2, holding in 50 knot winds (R1-11).....	60
Figure 78: Rudder and RPM – Hour 2, holding in 50 knot winds (R1-11).....	61
Figure 79: Track-plot – Hour 3, holding in 50 knot winds (R1-11).....	61
Figure 80: Rudder and RPM – Hour 3, holding in 50 knot winds (R1-11).....	62
Figure 81: Tug assisted track-plot – initial rotation, falling off 50 knot winds (R1-12)	63

Figure 82: Rate of turn – falling off 50 knot winds (R1-12)..... 63

Figure 83: Tug assisted track-plot – “in irons”, falling off 50 knot winds (R1-12) 64

Figure 84: Tug assisted track-plot – kick ahead, falling off 50 knot winds (R1-12) 64

Figure 85: Tug assisted track-plot – final rotation, falling off 50 knot winds (R1-12)..... 65

Figure 86: Tug assisted track-plot – falling off 50 knot winds (R1-12) 65

Figure 87: Tug line force – falling off 50 knot winds (R1-12)..... 66

Figure 88: Tug assisted track-plot – initiating high speed turn, 50 knot winds (R1-13)... 67

Figure 89: Tug assisted track-plot – high speed turn, 50 knot winds on quarter (R1-13)67

Figure 90: Rate of turn – high speed turn, 50 knot winds (R1-13) 68

Figure 91: Tug line force – high speed turn, 50 knot winds (R1-13) 68

Figure 92: Tug assisted track-plot – high speed turn, 50 knot winds (R1-13)..... 69

List of Appendix A References

Reference 1: BC Coast Pilots / Pacific Pilotage Authority Navigational Risk Assessment

1 Overview of Simulation Study

The Nisga'a Nation, Rockies LNG Limited Partnership (Rockies LNG) and Western LNG LLC (via its subsidiary, Western LNG ULC) are proposing to jointly develop the Ksi Lisims LNG - Natural Gas Liquefaction and Marine Terminal Project (the Project). The Project includes a floating natural gas liquefaction facility and marine terminal at Wil Milit on the north coast of British Columbia (North Coast) at the northern end of Pearse Island. The marine terminal site (Site) is approximately 15 kilometres west of the Nisga'a community of Gingolx.

Westmar Advisors Inc. (Westmar) has been retained to complete a navigation safety assessment (NSA). The NSA is part of the Project's application for an Environmental Assessment Certificate (the Application). This simulation analysis (the Study) was undertaken as part of the NSA and was conducted by LANTEC Marine Inc. (LANTEC) on behalf of Westmar. Additional navigation simulations will be completed before the start of operations and will be the subject of approval conditions.

The marine route selected for the Project, from open ocean to the Triple Island Pilot Boarding Station and through compulsory pilotage waters to the Site in Portland Canal, has been in use for many years by commercial vessels. The British Columbia Coast Pilots Ltd. (BCCP) are familiar with the marine route, and annually guide hundreds of similar-sized vessels through the western portion of the marine route to the Port of Prince Rupert. The voyage segment between the pilot station and Lucy Islands is frequented by LPG carriers calling at Trigon Pacific Terminals on Ridley Island, and Pembina Prince Rupert Terminal at Watson Island. The remainder of the marine route is navigated regularly by the BCCP when moving vessels to and from the Port of Stewart at the head of Portland Canal. As the marine route is already trafficked by deep-draught vessels, this simulation has endeavoured to remain consistent with the safe navigation movements, procedures, and rules already established for the North Coast, with a focus on assessing the unique characteristics of LNG carriers and assessing their operational limits.

1.1 Simulation System

The analysis was conducted by LANTEC using a Kongsberg Desktop Simulator with the K-Sim Ship Bridge Simulator software. The core software system, area database and environmental models are identical to those used for numerous other simulation analysis for projects in BC and globally (desktop and manned) and is compatible with the PSTAR simulator in Vancouver owned by the Pacific Pilotage Authority (PPA) and the BCCP.

From a pure simulation systems and mathematical standpoint, the desktop simulator has the same fidelity / accuracy as a full-mission simulator and encompasses both hydrodynamic (vessel motion) and physical simulation (vessel and physical object interaction). The primary differences are the control systems for the simulated ships, and the degree of human environmental immersion and participation. With the desktop system, all aspects of the simulation and ship control mechanisms are being controlled by one computer with a single user interface for the test director. This contrasts with the immersive full-mission ship and tug simulator, where a tug captain using real control equipment drives each tug, and a real pilot with real controls and radio devices controls the ship and coordinates all tug activity. Additionally, with desktop / fast-time simulation, all analysis is based on assessment of numerical outputs and data plots of key environmental and ship control parameters.

As such the desktop system can effectively develop an initial assessment of aspects including:

- How a vessel is affected by wind, tidal stream, and other environmental effects;
- Examining its handling characteristics including its response to propeller, rudder, tug orders and the overall ability to maintain an acceptable level of steering and positional control;
- Determining drift angle and swept path tracks under specific environment conditions throughout a marine route and to monitor the distance that the vessel passed shoals;
- Determining the likely range of applied tug forces needed both to conduct berthing operations and to respond to steering and/ or propulsion failures; and
- The effect of sea state / wave motion on a tug's ability to work and variations in its towline load.

Using desktop simulation is considered highly suitable for the intended scope of the Study. The goal was to record a broad selection of data over a wide range of environmental conditions to establish the level of steering and positional control that an LNG carrier could maintain during transits under typical day-to-day operating conditions.

1.2 Study Goals

At this early stage of the Project, the aim of the Study is to establish the routing from the pilot station to the marine terminal, and vice versa, can be conducted with a level of navigation control (vessel steering and positional control) that is safe and consistent with the norms adhered to in the waters of North Coast. These simulations do not serve as a substitute or replacement for the full-mission bridge simulations (FMBS) required as part of the joint BCCP / PPA Navigational Risk Assessment (NRA) process (see Appendix A).

The goals for the Study included an assessment of the following:

- Assess the marine route for the design vessels over a range of conditions, to draw conclusions about the overall navigational safety of the marine route and the limiting operational conditions;
- Determine the factors and variables having the strongest influence on vessel manoeuvrability;
- Recommendations for FMBS with respect to specific areas or issues requiring further assessment.

Given that certain elements of the marine terminal design are still being finalized, this simulation does not assess manoeuvres to and from the FLNG berths, these will be determined using FMBS. Consistent with LNG terminal operations around the world, berthing tugs will be used during berthing / unberthing operations. If required, LNG carriers and NGL product vessels will be accompanied by an escort tug, where necessary. The number and base location for the tugs is to be established during detailed project planning.

1.3 Ship Models

This Study was conducted using existing proven models from the Kongsberg simulation model library. Design LNG carriers for the Project range from approximately 140,000 m³ to of 217,000 m³ capacity. LNG carriers calling at the marine terminal are not forecast to exceed approximately 180,000 m³ capacity. The two floating liquefaction, storage, and off-loading barges (FLNGs) can receive LNG carriers up to 217,000 m³ capacity (315 m x 50 m x 12.0 m). The assessment was performed with a 217,000 m³ LNG carrier as it represents the largest design vessel with the deepest draught.

Tests were then performed with a 145,000 m³ LNG carrier. This size of LNG carrier is typically single screw and does not have the propulsion redundancy found on new and larger LNG carriers with twin screws (LNG carriers in the 180,000 m³ capacity range are forecast to call more frequently). Many of the LNG carriers to call on the marine terminal will likely be new-build ships designed and contracted specifically for the Project.

The tug modelled, for runs that include a tug, is a RAstar 3200. This tug is employed in the transit of Brown Passage and Chatham Sound for ships calling on Trigon Pacific Terminals in Prince Rupert.

Particulars of the vessels are listed in the following table:

Table 1: Vessel Particulars

Vessel Type	Model Name	Displacement (laden / ballast) [t]	Length LOA [m]	Beam [m]	Draught Forward [m]	Draught Aft [m]
217,00 m ³ LNG (twin screw)	Gas19	146,459 / 113,100	315	50	12.0 / 9.39	12 / 9.44
145,000 m ³ LNG	Gas17	115,350 / 95,550	285.4	43.4	11.71 / 9.18	11.71 / 10.54
NGL Product Vessel	Tank15	21,219 / 14,200	144.1	23	7.59 / 4.27	9.17 / 7.59
RAstar 3200	Tug52	866	32	12.8	5.25	5.25

1.4 Area Model

The simulation analysis used a high-fidelity 3D geographical area model with coverage of all of Dixon Entrance (from seaward of Langara and Forrester Islands), Hecate Strait, Chatham Sound, Portland Inlet, and Portland Canal to the northern tip of Pearse Island. It was last updated by Kongsberg in 2020 with the latest available Canadian Hydrographic Service (CHS) electronic chart data. For this desktop analysis, the existing model was not modified to include details of the marine terminal.

2 Marine Route and Metocean Conditions

The Site is near the north-eastern tip of Pearse Island at the south end of Portland Canal. LNG carriers entering this area from the open ocean pass to the north of Graham Island (Haida Gwaii) and transit through the southern portion of Dixon Entrance for approximately 80 nautical miles before entering the compulsory pilotage area. The entire area is within the boundaries of the Prince Rupert Marine Communications and Traffic Services (MCTS).

Figure 1: Site Location and Overall Marine Route

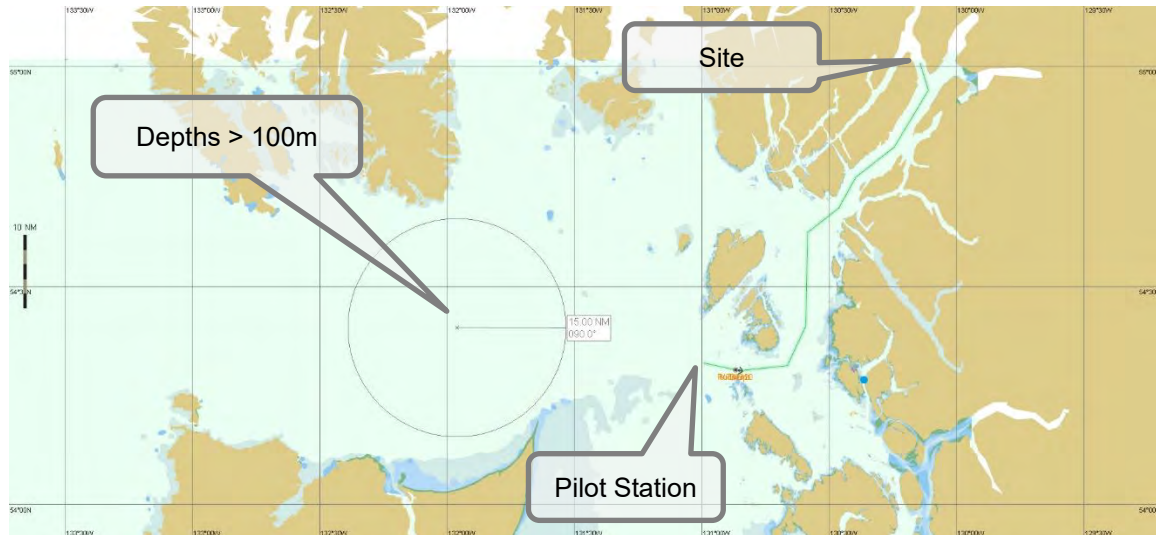

The overall transit from the point of pilot embarkation, to within one nautical mile of the marine terminal (where the LNG carrier will conduct multi-tug assisted arrival / departure manoeuvres) is approximately 64 nautical miles.

2.1 Detailed Description – Simulation Test Route

The selected marine route commences near the Triple Island Pilot Boarding Station. The approach through Dixon Entrance is deep and wide enough it is considered similar to open ocean transit and not assessed. For testing purposes, a marine route was selected that follows the same general path (in the area that is applicable) as used by the pilots when taking vessels to and from Stewart. The test route track-lines and waypoint coordinates used for both the inbound and outbound passages were identical as the low volume of vessel traffic allows a ship to navigate mid-channel as opposed to offsetting to the starboard side of the channel. This methodology ensured that the test ship maintained the maximum distance possible from any navigational hazards. Additionally, a mid-channel route allows for the option where a pilot deliberately offsets or adapts the marine route to the prevailing environmental circumstances such that the ship can favour an “updrift position” to allow for the anticipated vessel trajectory in the event of loss of steering and or propulsion. Additionally, for illustration and scale purposes, a 500-metre-wide corridor was set on each side of the track centreline and is depicted in all vessel track-plots. The coordinates of the test route waypoints are provided in Table 2 below:

Table 2: Route Coordinates

Waypoint	Latitude (°'/decimal')	Longitude (°'/decimal')	Course Inbound / Outbound
1	N54°19.5418'	W130°59.6460'	102° / As required
2	N54°18.4799'	W130°51.1004'	084° / 282°
3	N54°18.7848'	W130°46.1349'	084° / 264°
4	N54°19.1695'	W130°39.8790'	025° / 264°
5	N54°24.6515'	W130°35.5014'	001° / 205°
6	N54°37.4195'	W130°35.1193'	052° / 181°
7	N54°40.7473'	W130°27.7725'	029° / 232°
8	N54°44.9642'	W130°23.7352'	052° / 209°
9	N54°49.0464'	W130°14.6936'	031° / 232°
10	N54°56.7671'	W130°06.6473'	343° / 211°
11	N55°00.4664'	W130°08.6141'	As required / 163°

Based on the waypoint selection used in this simulation analysis, for much of the voyage the 1,000-metre-wide track corridor (500 metres each side of centreline) remains more than 1 nautical mile from shallow water. The green shaded zone of the track corridor is depicted in all track-plot images to provide an illustration of the available manoeuvring space each side of centreline that can be used to affect passing with other vessels. It is recognized that individual pilots may not follow these exact course lines, however it demonstrates that through careful route planning, it is possible for much of the voyage to maintain a track corridor that is more than 1 nautical mile from any shoals. For testing purposes, the pilotage route was divided into three segments. Specific details on each segment, the proximity to shoals, and prevailing environmental conditions are provided in the sections which immediately follow.

2.2 Western Route Segment

The westernmost segment of the marine route (inbound and outbound) is approximately ten nautical miles (19 kilometres) in length and lies between the pilot station (boat or helicopter transfer) east through Brown Passage until approximately one nautical mile east of Hanmer Rock's. This portion of the marine route is the most navigationally constrained. There are shoals, rocks and islets that lie within 0.5 nautical miles of the vessel's planned track line. Although vessel traffic is not dense, this is the section of the voyage most used by other vessels including all commercial traffic to and from the Port of Prince Rupert.

Note in Figure 2 below that depths of 15 metres (at chart datum) or less are highlighted in red colour, as at low water with waves of 2 metres or more, they would represent a potential grounding risk for a loaded LNG carrier of 217,000 m³ capacity. The vessel track line is shown in green, with the 500-metre-wide corridor on each side of centreline.

Figure 2: Simulator Chart Zoom View – Western Segment

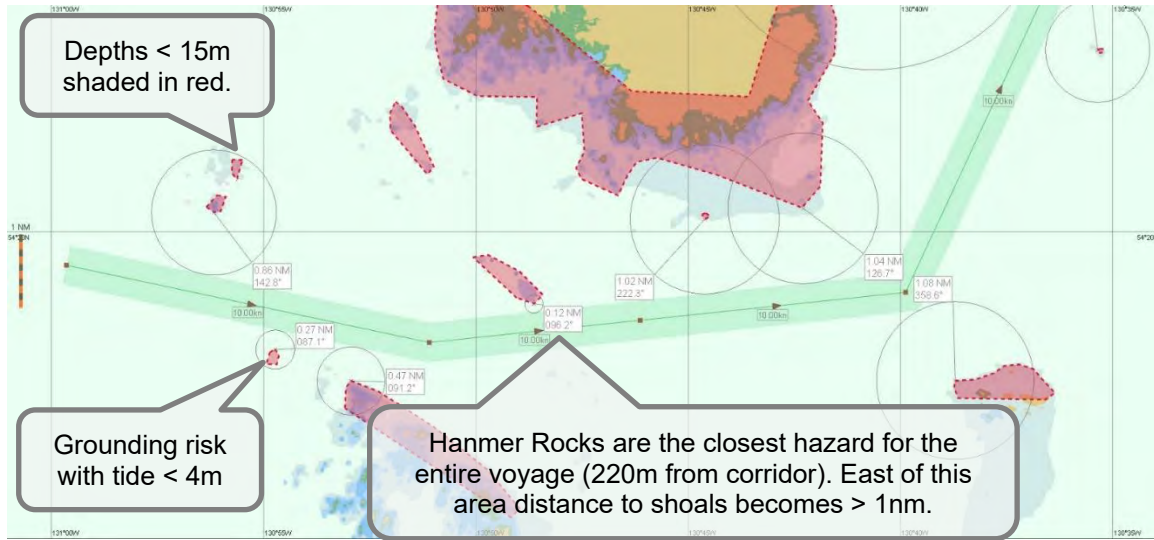

The vertical tidal range in this area can exceed 7 metres, and the mean tide level exceeds 3 metres, but there are at least two occasions each day when the tide levels are at their lower extremities (< 2.0 metres) for a period of one hour or more. There are shoals, such as those near Buoy 60 which only present a grounding risk to a loaded ship when the tide is less than 4.0 metres, however the shallows around Triple Island, and Hammer Rocks present a potential grounding risk at all tidal levels. See typical tidal curves in Figure 3 below:

Figure 3: CHS Tidal Graph – Prince Rupert

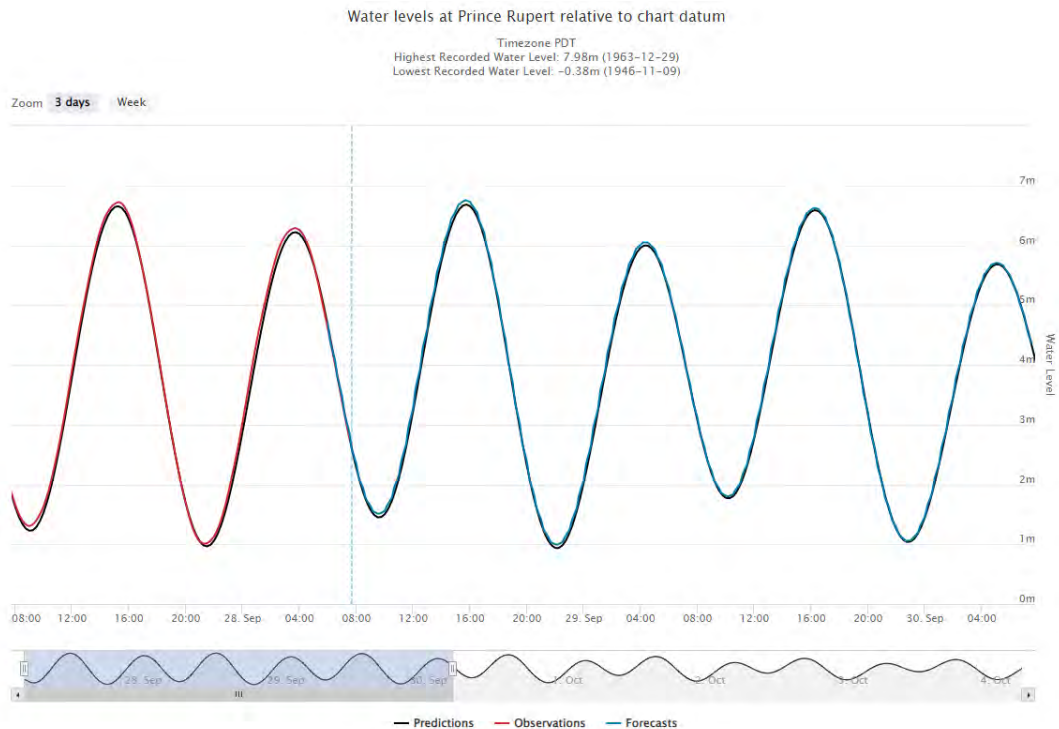

The wind can be from most directions. However, stronger winds tend to be predominately from the southeast quadrant with sufficient frequency that this was the prevailing circumstance for certain simulation tests. See annual historical wind probability data in Table 3 below noting that winds of 9 metres per second (21.4 knots) occur predominately from the east to south quadrant as illustrated by the green text:

Table 3: Directional Probability – Wind Direction and Speed Prince Rupert

	2 m/s	5 m/s	9 m/s	11 m/s
N	2.73%	0.68%	0.09%	0.00%
NNE	1.15%	0.60%	0.02%	0.00%
NE	2.03%	1.85%	0.21%	0.05%
ENE	3.53%	6.03%	2.06%	0.28%
E	3.01%	3.72%	2.56%	0.62%
ESE	1.87%	2.37%	1.46%	0.40%
SE	2.14%	8.53%	8.08%	4.25%
SSE	1.38%	3.29%	3.34%	1.59%
S	1.34%	1.12%	0.46%	0.18%
SSW	0.88%	0.61%	0.33%	0.06%
SW	1.07%	0.79%	0.26%	0.04%
WSW	1.43%	1.00%	0.26%	0.03%
W	2.61%	2.47%	0.55%	0.09%
WNW	2.14%	4.55%	1.04%	0.07%
NW	1.65%	2.41%	0.21%	0.01%
NNW	1.24%	0.99%	0.13%	0.02%

**Note: Green text in Table 3 illustrate that strong wind > 9 m/s originate most frequently from the SE quadrant.*

2.3 Central Route Segment

The central route segment is an extensive area from east of Hanmer Rocks, proceeding east and north through Chatham Sound until the entrance to Portland Inlet near Somerville Island. Although this is still a mandatory pilotage area, the marine route can be considered near coastal as opposed to navigation within a constrained waterway. For much of this transit, the LNG carrier track will be more than 1.5 nautical miles from any navigational hazard. Except for Moore Shoal (depth 13.4 metres at chart datum) this area is free of unmarked hazards. See Figure 4 to Figure 6 below:

Figure 4: Simulator Chart Zoom View – Moore Shoal to Pearl Harbour

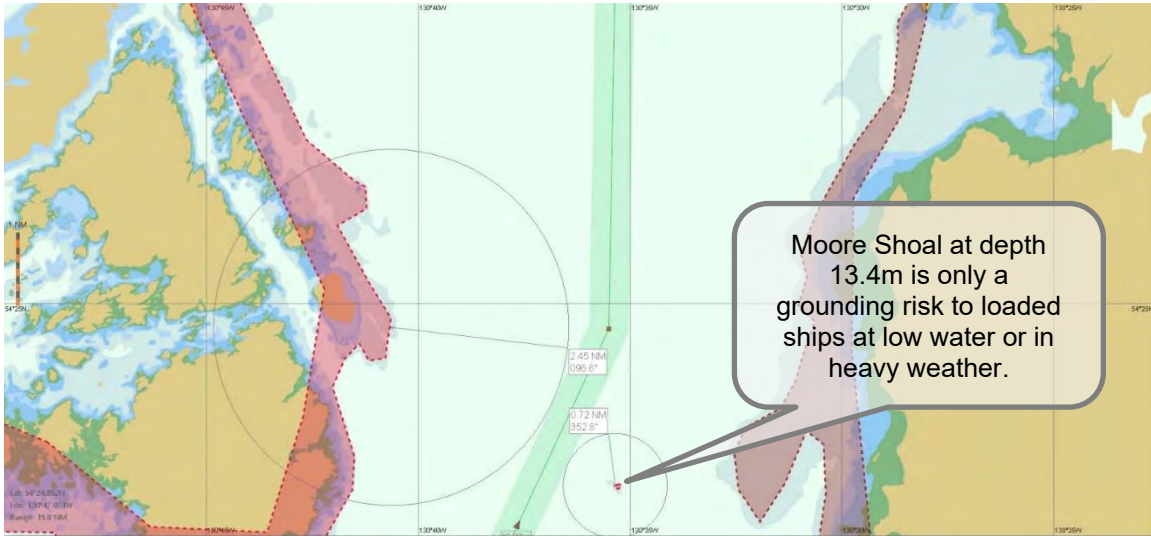

Figure 5: Simulator Chart Zoom View – Pearl Harbour to Pointer Rocks

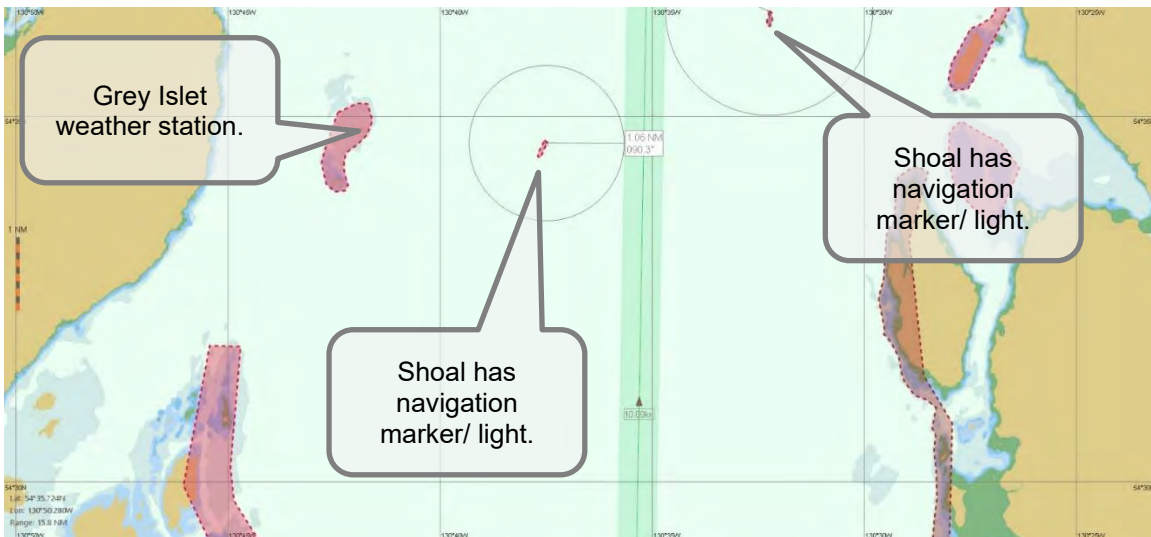
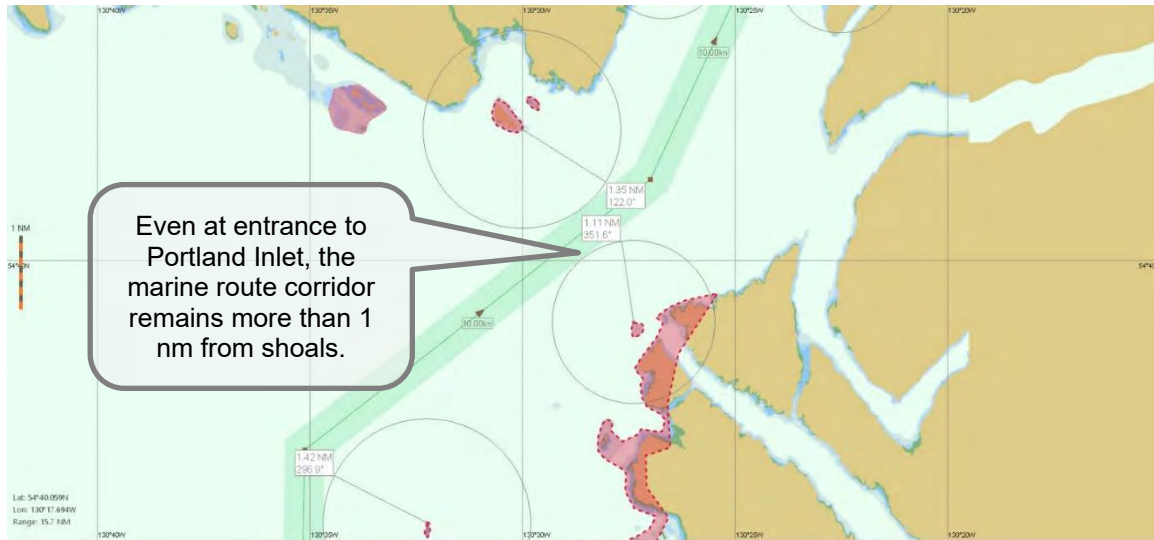

Figure 6: Simulator Chart Zoom View – Pointer Rocks to Somerville Island



The wind patterns in the southern portion of this route segment are similar to the western segment with the south-easterly flow being predominate. In this region, however, swell effects are greatly reduced and there are lower overall significant wave heights. On the west side of Chatham Sound, Dundas Island, Melville Island, and the island groups to the south provide considerable lee / fetch limiting effects as does the Tsimpsean Peninsula on the east side of Chatham Sound. In the more northern part of this segment, the wind tends to be more prevalent from a southerly direction, and strong north-easterly outflow winds coming out of Portland Inlet are also very common. With strong southerly winds there is more fetch, and waves of 2 to 3 metres are not uncommon. Winds more than 15 metres per second (29 knots) occur with a frequency of 12.93% at Grey Islet. See Table 4 below and note that the green highlights show the most frequent direction of origin for winds above 24 knots. Also note that winds above 40 knots (21m/s) are most frequently outflow winds from the northeast.

Table 4: Directional Probability – Wind Direction and Speed Grey Islet

Speed (m/s)	Frequency of occurrence (%)							
	N	NE	E	SE	S	SW	W	NW
0-3	2.264	1.537	1.932	2.053	3.444	2.050	1.616	1.272
3-6	2.907	2.356	2.856	2.362	6.360	3.852	2.263	2.441
6-9	1.111	3.684	2.379	2.857	5.433	2.036	1.215	1.885
9-12	0.421	5.322	1.089	2.737	4.379	0.644	0.318	0.339
12-15	0.189	5.151	0.271	1.409	2.345	0.206	0.056	0.032
15-18	0.179	4.694	0.104	0.885	1.511	0.052	0.016	0.008
18-21	0.158	2.313	0.021	0.397	0.620	0.013	0.002	0.001
21-24	0.081	1.001	0.003	0.162	0.212	0.002	0.000	0.001
24-27	0.052	0.217	0.000	0.067	0.028	0.001	0.000	0.000
27-30	0.021	0.060	0.000	0.018	0.007	0.000	0.000	0.000
30-33	0.002	0.008	0.000	0.004	0.001	0.000	0.000	0.000
33-36	0.000	0.000	0.000	0.001	0.000	0.000	0.000	0.000
Total	7.385	26.342	8.656	12.953	24.341	8.857	5.487	5.980

*Note: note that the green text shows the most frequent direction of origin for winds above 24 knots.

2.4 Northern Route Segment

The northernmost segment of the transit, within the confines of Portland Inlet and the southern portion of Portland Canal, can be described as fjord navigation where steep mountain slopes adjoin the edge of the inlet. Commercial vessel traffic is light, with ships occasionally calling on Stewart, BC (approximately 30 cargo vessels passed in 2019). This segment is approximately 20 nautical miles in length with a deep channel (> 500 metres in places) where with very few exceptions, the grounding risk is only within a few metres of the shoreline. The topography also dictates that the area is lightly inhabited, with few artificial light sources to use as reference points. Because of the extreme water depths, there are few (and little real need for) navigational aids with lights only at Lizard Point, and Ramsden Point. The area however lends itself to excellent radar navigation, and large vessels can use the entire width of the channel without issue.

Due to topographic effects, the winds in the Portland Inlet and Canal funnel, and take on the form of inflow or outflow winds that run parallel to the mountain ranges / sides of the channel. The area can also experience katabatic wind effects, especially in winter, where cold air further up the valley flows down producing strong outflow winds. These effects can be localized and achieve velocities over 40 knots, usually for brief periods. These winds are also often forecast in advance.

From a navigation perspective, Portland Inlet is wide enough that for most of the transit the marine route (with 500 metre offset allowance) can maintain more than one nautical mile from the shoreline. The most constrained portion of the marine route in Portland Inlet is passing Trefusis Point where the distance from the marine route (with 500 metre offset allowance) distance to shoreline is still 0.75 nautical miles. At the transition from Portland Inlet into the Portland Canal, for the last five nautical miles of the voyage, the distance to the shoreline is reduced to less than 0.5 nautical miles and it is within this area where tugs will assist the ship as it conducts berthing and unberthing manoeuvres. See Figure 7 to Figure 10 below:

Figure 7: Simulator Chart Zoom View – Entry to Portland Inlet at Somerville Island

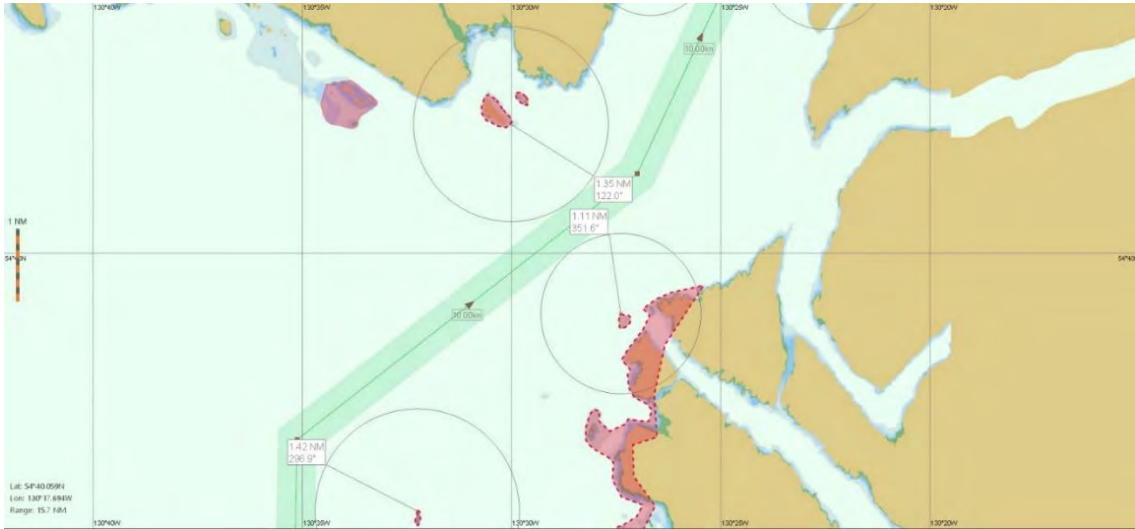

Figure 8: Simulator Chart Zoom View – Somerville Island to Lizard Point



Figure 9: Simulator Chart Zoom View – Lizard Point to Flat Island

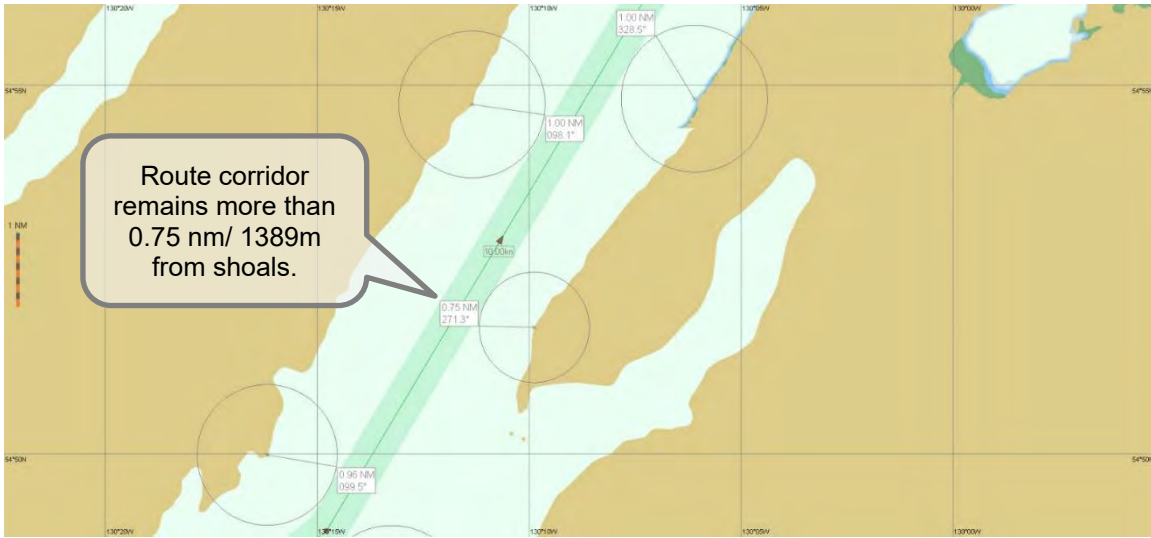
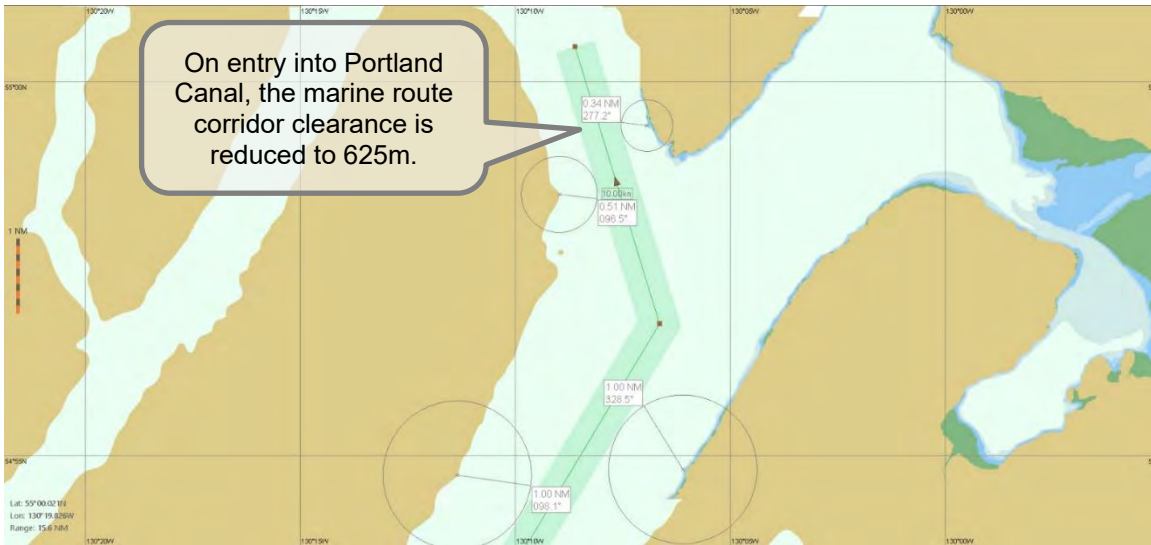

Figure 10: Simulator Chart Zoom View – Flat Point to Whiskey Bay



Near the Site, the wind is predominately (with approximately equal distribution) from the northern or southern quadrants, especially if the velocities exceed 5 metres / second or 10 knots. The tidal cycles are also very similar in pattern and magnitude to Prince Rupert with mean sea level being 3.7 metres above chart datum. Tidal currents near the marine terminal have been recorded for one year using an Acoustic Doppler Current Profiling (ADCP) buoy and indicate an average current flow of less than 0.5 knots (23 cm/sec) with the flow 95% of the time being less than 1.1 knots (55.8 cm/sec) and a maximum rate of 1.78 knots (90.8 cm/sec), see Table 5 and Figure 11 below. These current velocities will be a factor to consider when conducting arrival and departure manoeuvres in FMBS.

Table 5: One Year Tidal Current Statistics

Speed (cm/s)	min	1%	5%	25%	50%	mean	75%	95%	99%	std	max	total #
5.8 m below surface	0.1	1.4	3.1	9.7	19.3	23.1	33	55.8	70.6	16.7	90.8	6049
10.6 m below surface	0.1	1.2	2.7	9	18.5	22.4	31.9	55.5	68.7	16.7	90.2	6049
18.6 m below surface	0.1	0.8	2.3	8.4	17	20.3	29.2	49.4	60.4	14.9	78.9	6049

Figure 11: Observed Current Velocity Percentile – Site ADCP Buoy at 10.6 m

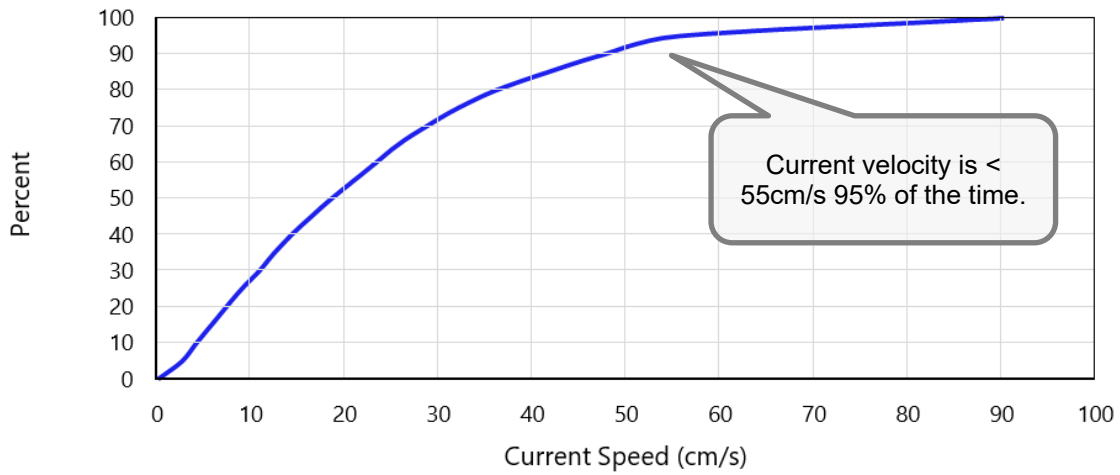

3 Summary of Real Time Simulation Analysis

This simulation analysis assessed the navigation route that will be followed by LNG carriers and NGL product vessels to and from the marine terminal. At this stage of the Project, it is critical to identify any risk elements that need to be mitigated or managed, especially any elements that are new or unique, and that would lie beyond the boundaries of the protocols and operational procedures already in use by various regulatory agencies such as Transport Canada, Canadian Coast Guard, Department of Fisheries and Oceans, and the PPA, and user groups such as the BCCP. This simulation analysis will later assist when entering the combined PPA / BCCP NRA process (see Section 3.1.4 for details). This assessment does not try to establish operational procedures or limits for items such as berthing and unberthing operations as this will be addressed during FMBS with the participation of all stakeholders.

3.1 Existing Operational Rules and Protocol

As per all commercial marine traffic, vessels proceeding to and from the marine terminal will be subject to adherence to the following established navigational and risk management processes:

3.1.1 Marine Traffic Communication Service

Before entering Canadian territorial waters, all vessels must check in with Prince Rupert MCTS. The check in call includes identifying if the ship is experiencing any mechanical difficulties or has deficiencies with any of its navigation or communication equipment. Before and after pilot embarkation, the MCTS can provide the ship's master with important information related to the movements of other vessel traffic, poor weather conditions, and notice of any other unusual or unforeseen marine hazards / operational irregularities.

3.1.2 Mandatory Pilotage

The area between the eastern end of Dixon Entrance and the marine terminal is subject to compulsory pilotage under the jurisdiction of the PPA and with piloting services provided by the BCCP. The BCCP has extensive experience piloting a wide variety of vessel types. The Port of Prince Rupert has undergone a major expansion over the last 20 years and is now the third busiest port in Canada. As discussed in Section 2.2 above, the western segment of the selected marine route is common with that of vessels calling on Prince Rupert, this includes regular visits by other high windage area ships such as 366m to 400 m long container vessels, and much more deeply loaded vessels such as 250,000 deadweight (dwt) bulk carriers with maximum draughts up to 20 metres. Additionally, LPG ships already frequent terminals in Prince Rupert.

3.1.3 Tugs

There are no formalized escort tug requirements applicable to the selected marine route. The PPA is drafting guidance on the tug requirements for the North Coast, including routes into and out of Prince Rupert. The tug requirements for the Project are to be established with FMBS, undertaken with relevant stakeholders.

For runs including a tug, a model of a RAstar 3200 was used.

3.1.4 Compulsory Pilotage Risk Assessment

The BCCP / PPA require a dedicated NRA to be performed for all terminals unused in five years, new terminals, modifications to existing terminals, significant changes to vessels size or class and any significant change in berthing procedures within the compulsory pilotage waters as defined in the *General Pilotage Regulations* under the *Pilotage Act*. This process dictates that the PPA, BCCP and the Project will collectively identify relevant authorities and stakeholders who will be involved or affected throughout the Project and determine the members of the Risk Assessment Committee (RAC). The RAC will determine the scope of the risk assessment and whether it will require a tabletop exercise, fast-time simulation, real time simulation, or live trials. The RAC will establish a critical path with timelines allowing for possible revised assessment through consultation with any affected parties and will include record keeping and a log of events and minutes for a specific project. Full details of this requirement are in Appendix A.

Given this requirement, berthing and unberthing simulations and any required emergency response simulations will be conducted during the RAC. At the time these simulations are completed the Project will have a more refined plan with respect to the layout of the marine terminal berths and tug provisioning.

3.2 Testing Methodology

This simulation analysis aims to address items that could apply over the entire life of the Project. Design LNG carriers for the Project range from approximately 140,000 m³ to of 217,000 m³ capacity. LNG carriers calling at the marine terminal are not forecast to exceed approximately 180,000 m³ capacity. From the perspective of assessing the marine route from an overall navigational, ship steering and positional control, as well as emergency response perspective, it was determined that the most prudent action would be to conduct an initial overall assessment and validation of navigational risk by using the 217,000 m³ LNG carrier as the reference benchmark. In this manner, it could be determined if the marine route was feasible for all LNG carriers up to 217,000 m³ capacity and to identify any areas where either navigational constriction or environmental variables create situations that might require unique or specific risk mitigation measures.

The first step in the analysis was to conduct an entire transit under conditions that would be considered typical to the region and would occur on a frequent basis; the parameters for this test are described below:

- One entire inbound transit was conducted with a ballasted 217,000 m³ LNG carrier to assess the level of steering and positional control that could be maintained with tidal current velocities of up to 1 knot, with winds from the prevailing southeast direction at a velocity of 30 knots in Chatham Sound and funnelling to 40 knots in Portland Inlet and Portland Canal. The ballasted LNG carrier was used on the inbound route, as this represents the condition in which the ship has the largest windage area and is most exposed to wind-induced rotation and drift. Key elements / parameters that affect navigational control / risk were then noted such as:
 - The amount of rudder needed to initiate / arrest planned turns / course alterations;
 - The amount of rudder carried to hold a steady course and to prevent wind-induced rotation;

- Vessel drift angle / swept path; and
- Cross track error.
- There was no tug assistance or intervention during the transit, and the engine telegraphs were left at the Half Ahead setting which corresponded to a water speed of approximately 10 knots.

A transit speed of 10 knots was used as a benchmark because it is believed to correspond approximately to a telegraph setting of Half Ahead in many LNG carriers (one of a ship's discrete propulsion power settings) and provides a good speed margin (4 to 5 knots) for an escort tug, if required, to overtake / manoeuvre / re-position around the LNG carrier.

Based on observations from the inbound simulated voyage, wind limit tests were then conducted with progressively elevated wind speeds with the 217,000 m³ capacity LNC carrier transiting both inbound and outbound through the western route segment (most navigationally constrained). A transit speed of 10 knots was used with 35 knot winds, and at a transit speed of 14 knots (64% telegraph setting), with wind speeds of 40 and 50 knots both from the southeast and northwest directions. This range of tests provided a good indication of the ability to transit the 217,000 m³ capacity LNC carrier on a reoccurring basis under day-to day operations with a good level of steering control, and precise navigational accuracy. The strongest wind velocity that was tested was 50 knots, and this was because the highest wind speed ever recorded by the weather buoy in Dixon Entrance is 54 knots, and as summarized in Table 4, winds at Grey Islet exceed 29 knots (15 m/s) with a frequency of only 12.93%, winds in excess of 40 knots (21 m/s) occur with a frequency of 1.95%, and above 50 knots with a frequency of 0.49%. One inbound and outbound transit of the western route segment was also conducted with a NGL product vessel at 14 knot transit speed (Manoeuvring Full) and 40 knot winds (considered maximum conditions for pilot transfer with a small vessel).

Tests were also conducted in Portland Inlet, near the junction of the Portland Canal to examine a situation where a LNG carrier had progressed in its transit, but winds had increased beyond forecasted levels such that berthing could not be conducted. A variety of manoeuvring techniques were tested both with and without tug assistance to determine that it would be possible for a 217,000 m³ capacity LNC carrier to safely hold position in this vicinity while waiting for the wind to abate.

3.3 Summary of Controlled Runs

A detailed listing of the runs is provided in Table 2 below. Run nomenclature is as follows:

- The letter designated the marine route segment – W for western, C for central, N for northern and R for the entire marine route;
- The first digit indicates vessel type – 1 for 217,000 m³ capacity LNC carrier, 2 for the 145,000 m³ LNG carrier, and 3 for NGL product vessel; and
- The second digit is the run number within a particular grouping.

Table 6: Simulated Test Runs

Run	Vessel	Scenario	Wind [kts]	Tide and Current	Figures
R1-1	217,000 m ³ LNG carrier	217,000 m ³ LNG carrier transit along the entire navigation route with its telegraph set at Half Ahead (water / ordered speed of 10.7 kts). Winds were modelled to represent the prevailing southeast / southerly wind patterns in Chatham Sound at a velocity of 30 kts, and an outflow wind in Portland Inlet and Canal with a velocity of 40 kts. The current was modelled to represent the period from 3 hours before to 3 hours after low water such that the ship was initially stemming an ebb tidal current and then entered Portland Inlet with a flood tidal flow.	SE/S 30 and Outflow 40	3 hrs before to 3 hrs after Low Water	12 to 28
R1-2	217,000 m ³ LNG carrier	217,000 m ³ LNG carrier quartering winds steering limit test; ship westbound from Beaver Rocks to Triple Island. Transit speed 10 kts with telegraphs set to Half Ahead.	SE 35	Low water ebb 1 kt	29 to 34
R1-3	217,000 m ³ LNG carrier	217,000 m ³ LNG carrier inbound, western segment of marine route. Telegraph set to Manoeuvring Full (14 kts water speed). Wind on quarter.	NW 40	Low water ebb 1 kt	35 to 40
R1-4	217,000 m ³ LNG carrier	217,000 m ³ LNG carrier outbound, western segment of marine route. Telegraph set to Manoeuvring Full (14 kts water speed). Wind on quarter.	SE 40	Low water ebb 1 kt	41 to 46
R1-5	217,000 m ³ LNG carrier	217,000 m ³ LNG carrier inbound western segment of marine route. Telegraph set to Manoeuvring Full (14 kts water speed). Wind on quarter.	NW 50	Low water ebb 1 kt	47 to 52
R1-6	217,000 m ³ LNG carrier	217,000 m ³ LNG carrier outbound western segment of marine route. Telegraph set to Manoeuvring Full (14 kts water speed). Wind on quarter.	SE 50	Low water ebb 1 kt	53 to 58
R1-7	NGL Product Vessel	NGL Product Vessel carrier quartering winds steering limit test; ship inbound from Triple Island to Beaver Rocks. Transit speed 14 kts with telegraphs set to Full Ahead.	NW 40	Low water ebb 1 kt	59 to 63
R1-8	NGL Product Vessel	NGL Product Vessel carrier quartering winds steering limit test; ship outbound from Beaver Rocks to Triple Island. Transit speed 14 kts with telegraphs set to Full Ahead.	SE 40	Low water flood 1 kt	64 to 68
R1-9	217,000 m ³ LNG carrier	217,000 m ³ LNG carrier turning through extreme winds near junction of Portland Inlet and Portland Canal– Low speed turn, full rudder, no tug assist.	Outflow 50	Ebb 1 kt	69 to 71
R1-10	217,000 m ³ LNG carrier	217,000 m ³ LNG carrier turning through extreme winds near junction of Portland Inlet and Portland Canal – Low speed turn rotating stern through the wind, full rudder, no tug assist.	Outflow 50	Ebb 1 kt	72 to 74
R1-11	217,000 m ³ LNG carrier	217,000 m ³ LNG carrier holding in extreme winds near junction of Portland Inlet and Portland Canal – downwind drift and then rotate bow through wind and steer upwind at low speed, no tug assist.	Outflow 50	Ebb 1 kt	75 to 80
R1-12	217,000 m ³ LNG carrier	217,000 m ³ LNG carrier turning through extreme winds near junction of Portland Inlet and Portland Canal – Low speed turn falling off wind / rotating stern through the wind, with tethered tug assist.	Outflow 50	Ebb 1 kt	81 to 87
R1-13	217,000 m ³ LNG carrier	217,000 m ³ LNG carrier turning through extreme winds near junction of Portland Inlet and Portland Canal – High speed turn rotating stern through the wind, with tethered tug assist.	Outflow 50	Ebb 1 kt	88 to 92

4 Results and Findings

From an overall navigational risk assessment perspective, the results of the Study are consistent with known risks identified through real-world experience from those who sail the area and previous simulation analysis for other projects within this region. Except for the western portion of the pilotage route between buoys 59 / 60 and Hanmer Rocks, (part of the marine route shared with the Port of Prince Rupert), for most of the voyage LNG carriers could follow a 1,000-metre-wide corridor that is over 0.75 nautical miles from any shoal that presents a grounding risk, and for approximately one-quarter of the transit the ship maintained a distance of over two nautical miles from any hazards. Additionally, the tested track segments were long (minimum of 5 nautical miles) with no requirement to make large course alterations when near hazards. As such the ship could be steadied on a heading to achieve its desired ground course, allowing for combined wind and current induced drift well before passing any navigational hazards. The only course alteration that took place within 1 nautical mile of shoal water was a course change of 18° to the northeast of Triple Island.

From a steering and positional control standpoint, the characteristics of LNG carriers are well known. Similar to large container vessels and automobile carriers with high windage areas, LNG ships are prone to wind-induced rotation and drift, especially at lower speeds, and when the wind velocity exceeds 25 knots. The ships have a fine underwater hull form with very good directional / course stability, and at high speeds steer well, even in strong wind. Fortunately, the nature of the transit with long straight track legs, deep water, and relatively few hazards (except as noted above) allowed the ship to be navigated with an elevated level of steering and positional control at a speed of 10 knots. Likewise, except for near Hanmer Rocks, and Triple Islands, the available time to respond to steering and propulsion emergencies was typically a minimum of 30 minutes before any possibility of entering shallow water.

Specific observations and findings are provided in the sections which immediately follow.

4.1 Steering and Positional Control: Day-to-Day Operations

The first validation test consisted of navigating the 217,000 m³ LNG carrier along the entire navigation route with its telegraph set at Half Ahead (water / ordered speed of 10.7 knots). Winds were modelled to represent the prevailing southeast / southerly wind patterns in Chatham Sound at a velocity of 30 knots, and an outflow wind in Portland Inlet and Canal with a velocity of 40 knots. The current was modelled to represent the period from 3 hours before to 3 hours after low water such that the LNG carrier was initially stemming an ebb tidal current and then entered Portland Inlet with a flood tidal flow. The goal was to determine the level of steering and positional control that could be maintained throughout the transit simply using rudder orders and navigating in a manner expected as part of day-to-day operations. This test illustrated that a 217,000 m³ LNG carrier could navigate the entire marine route with an elevated level of steering and positional control. As a point of reference, in the western section of the transit, through Brown Passage, which is the most navigationally constrained, the ship was navigated within 50 metres of track centreline. There was also a good margin of residual manoeuvring control as the courses were held carrying no more than 5° of rudder, the turn from the 102° to 084° course was conducted with 15° of rudder, and maximum drift angle (difference between heading and course over the ground) when steadying on the 084° course was 8°.

For all following diagrams, purple arrows denote wind direction, while green arrows show current.

Figure 12: Track-plot – Pilot Station to Triple Island (R1-1)

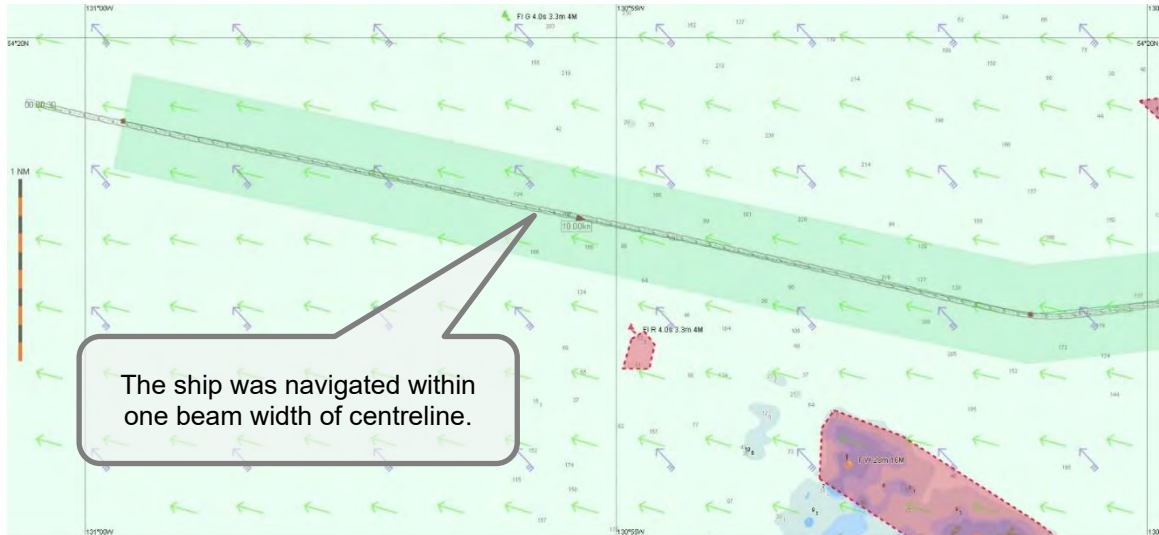

Figure 13: Track-plot – Brown Passage to Beaver Rock (R1-1)

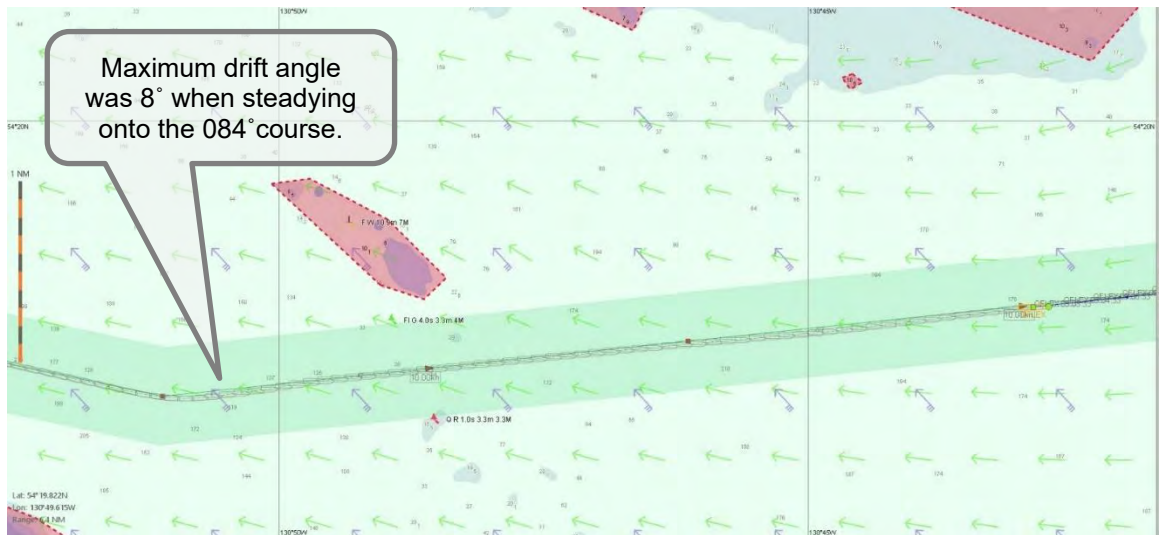

Figure 14: Applied rudder – Pilot Station to Beaver Rock (R1-1)

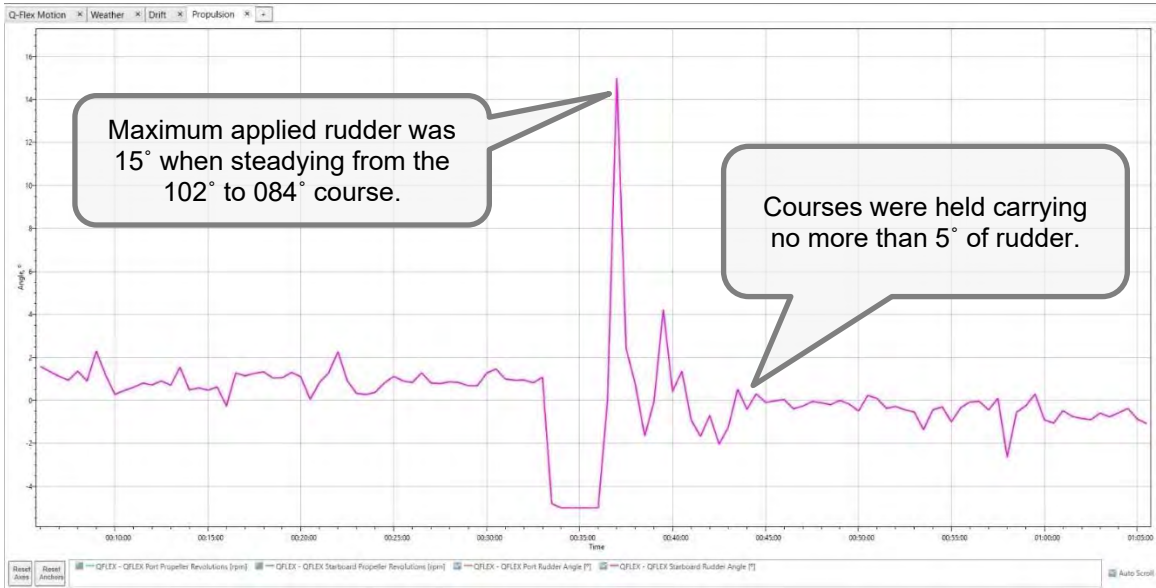
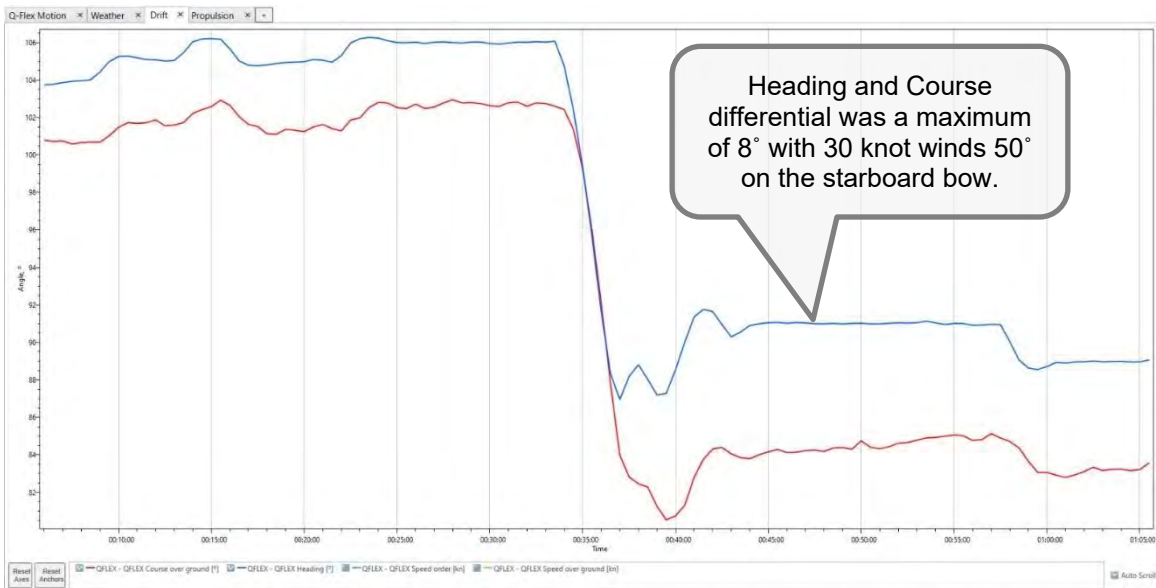

Figure 15: Applied rudder – Pilot Station to Beaver Rock (R1-1)



When conducting the largest course alteration along the marine route (59° from 084° to 025°) the relative wind angle changed from approximately 70° (on the starboard bow / beam) to 135° (on the starboard quarter). Throughout the turn the ship remained within 100 metres of the track centreline, and the turn was initiated with 20° of rudder. Once steady with the 30 knots of wind on the quarter (worse angle for wind-induced rotation) the ship was held on course carrying 5° to 8° of port rudder. See Figure 16 to Figure 18 below:

Figure 16: Applied rudder – altering from 084° to 025° (R1-1)

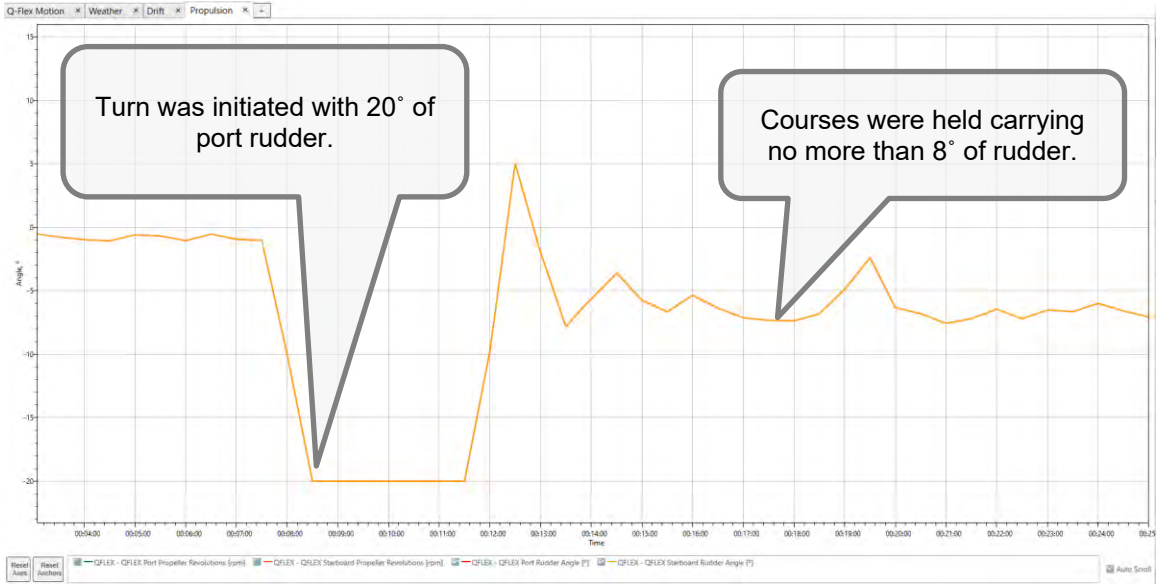

Figure 17: Heading vs course, wind on beam and quarter (R1-1)

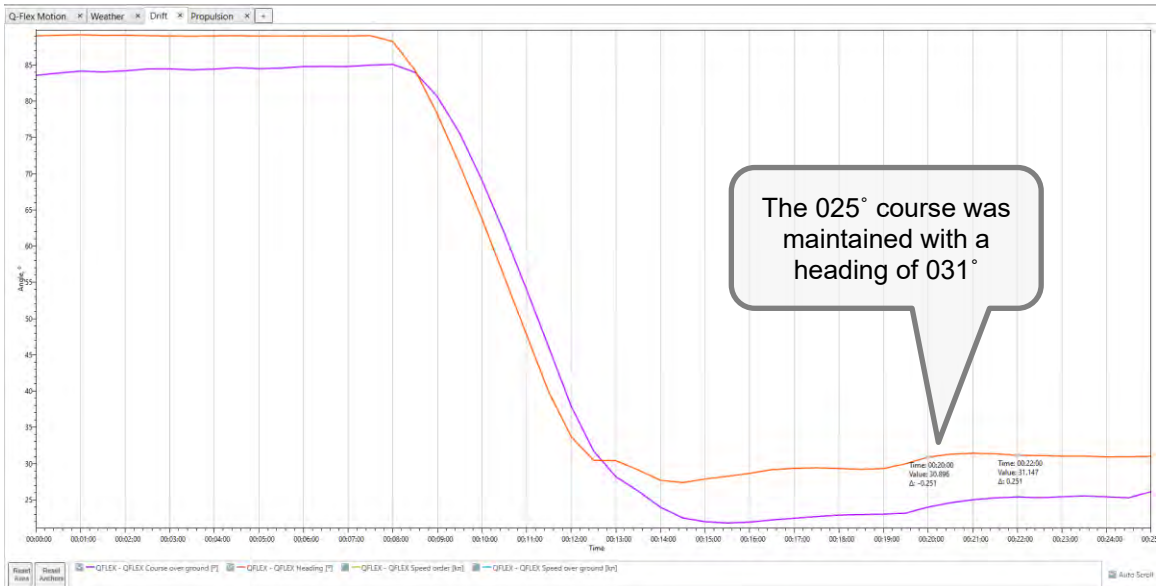
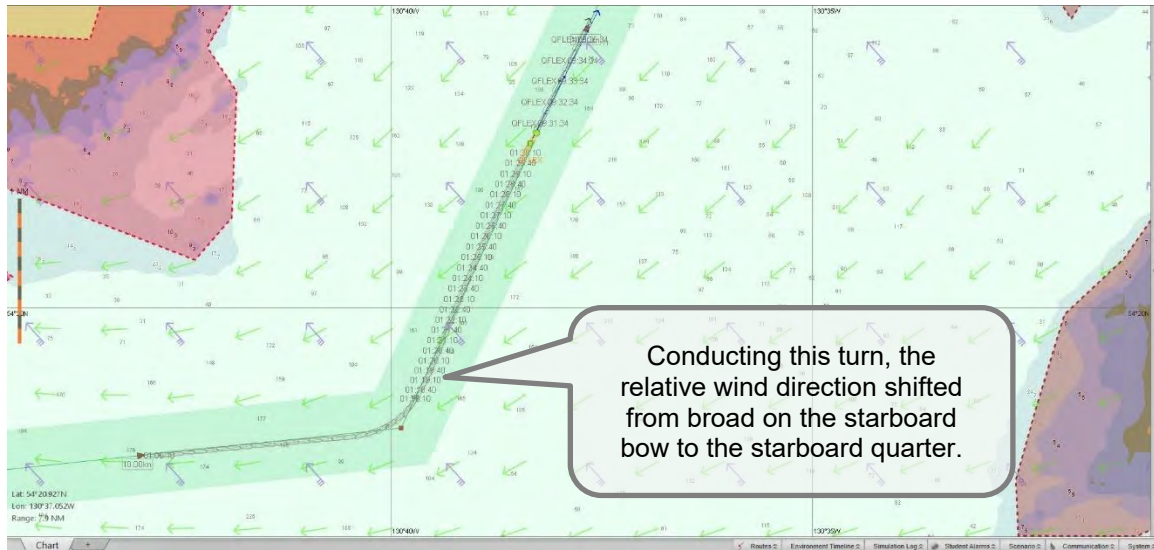

Figure 18: Track-plot – altering 084° to 025 (R1-1)



While proceeding north through Chatham Sound the wind remained on the starboard quarter and the course of 001° was realized by steering courses between 003° and 004°. For most of this route segment the ship was over 2 nautical miles from navigational hazards, yet it was easily kept within 100 metres of the track centreline. When passing the nearest hazard, at a range of 1.3 nautical miles the ship was exactly on the marine route centreline. The alteration onto the 052° course to approach Portland Sound was conducted with no more than 15° of starboard rudder, and 20° of port rudder was applied briefly to arrest the turn see Figure 19 and Figure 20 below:

Figure 19: Track-plot – nearest hazard on 001° course (R1-1)

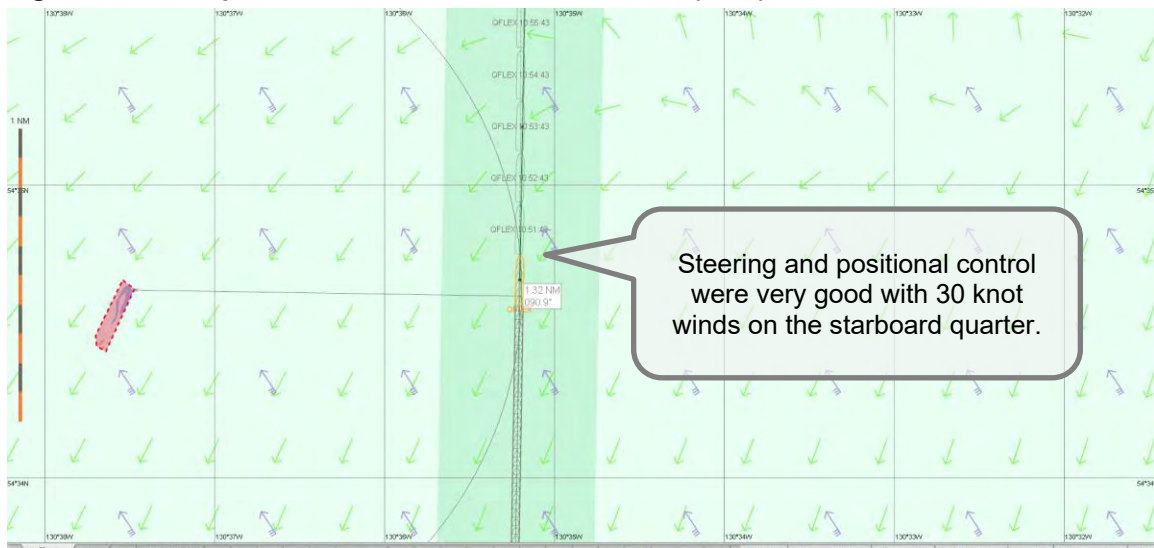
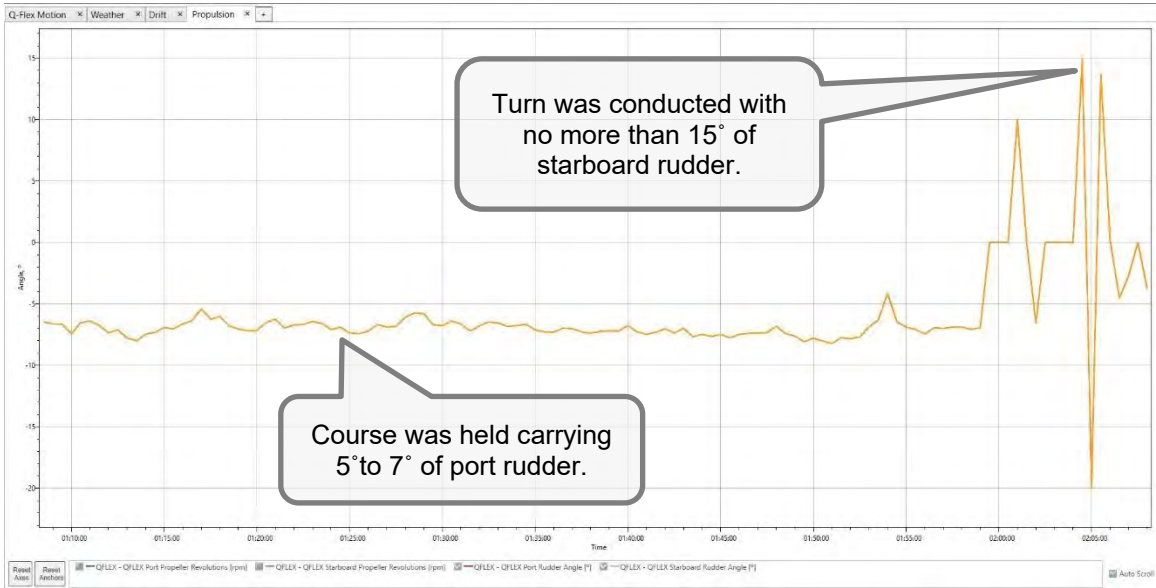

Figure 20: Applied rudder – 001° course and altering to 052 (R1-1)



As the 217,000 m³ LNG carrier approached Portland Inlet and passed the north end of the Tsimpsean Peninsula, the wind backed from the southeast to a northeast outflow and increased in speed to 40 knots. Steering and positional control remained good with very strong cross winds and a drift angle of 5° to 7°. Likewise, the alteration from the 052° course onto the 029° course was accomplished using only 15° of port rudder. See Figure 21 and Figure 22 below:

Figure 21: Heading vs course – 40 knot crosswinds (R1-1)

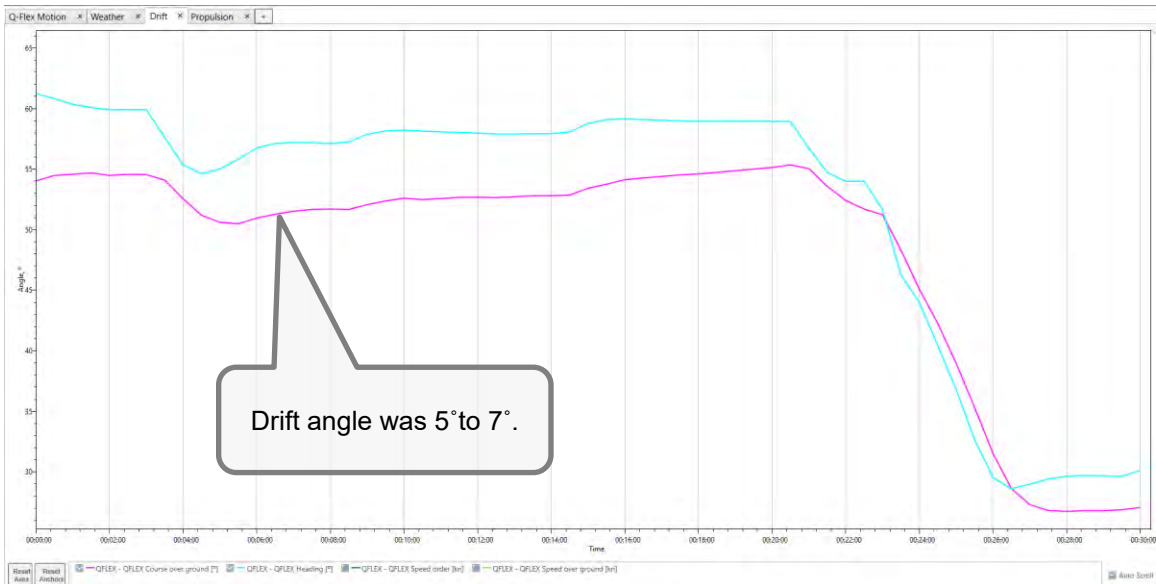
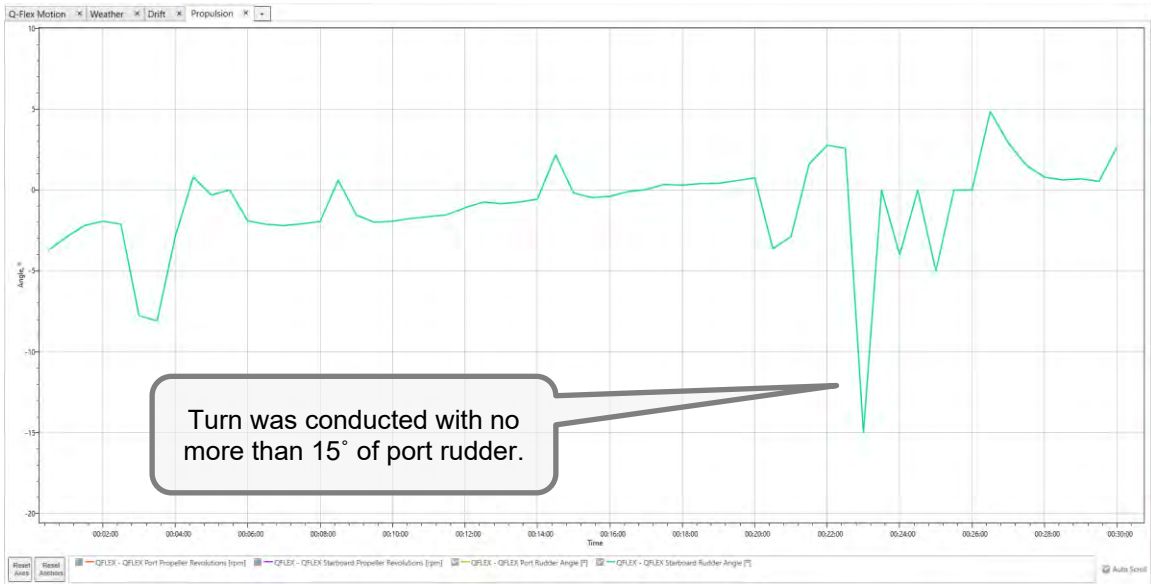

Figure 22: Applied rudder – 052° course and altering to 029 (R1-1)



Track deviation throughout the transit of Portland Inlet with 40 knot headwinds remained less than 100 metres from the planned centreline. See Figure 23 to Figure 26 below:

Figure 23: Track-plot – entering Portland Inlet wind NE 40 (R1-1)

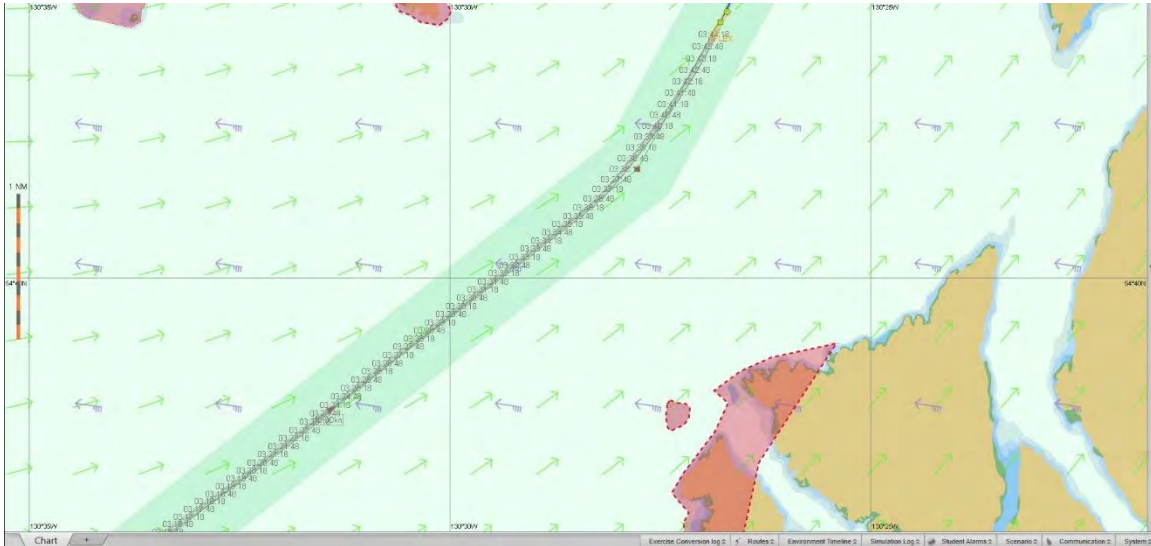

Figure 24: Track-plot – Portland Inlet altering 029° to 052 (R1-1)

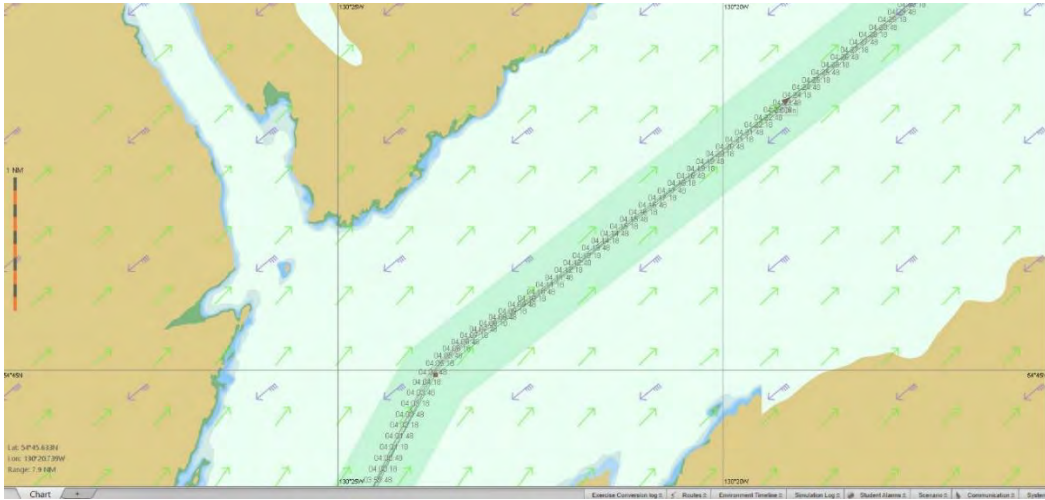

Figure 25: Track-plot – Portland Inlet altering 052° to 031 (R1-1)

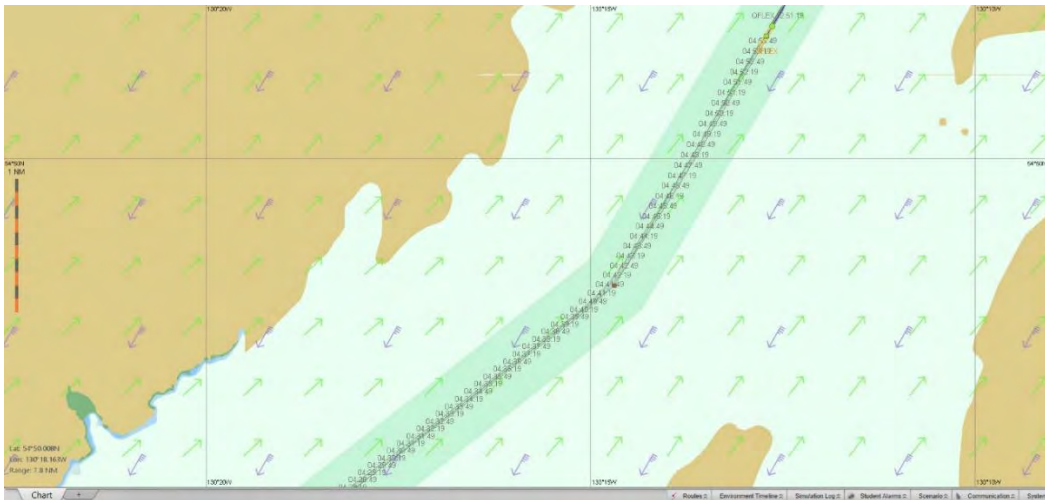
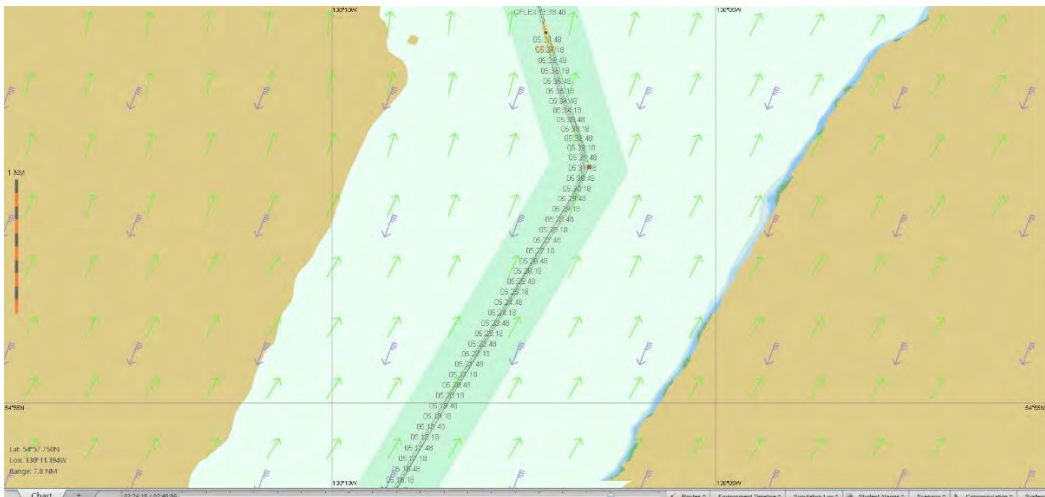

Figure 26: Track-plot – Portland Inlet altering 031° to 343 (R1-1)



The final inbound turn from the 031° course onto the 343° was conducted with 20° of rudder both to initiate and to arrest the turn. Once steady with the wind on the starboard bow, the deviation between heading and course was approximately 3°. See Figure 27 and Figure 28 below:

Figure 27: Applied rudder – altering from 029° to 343 (R1-1)

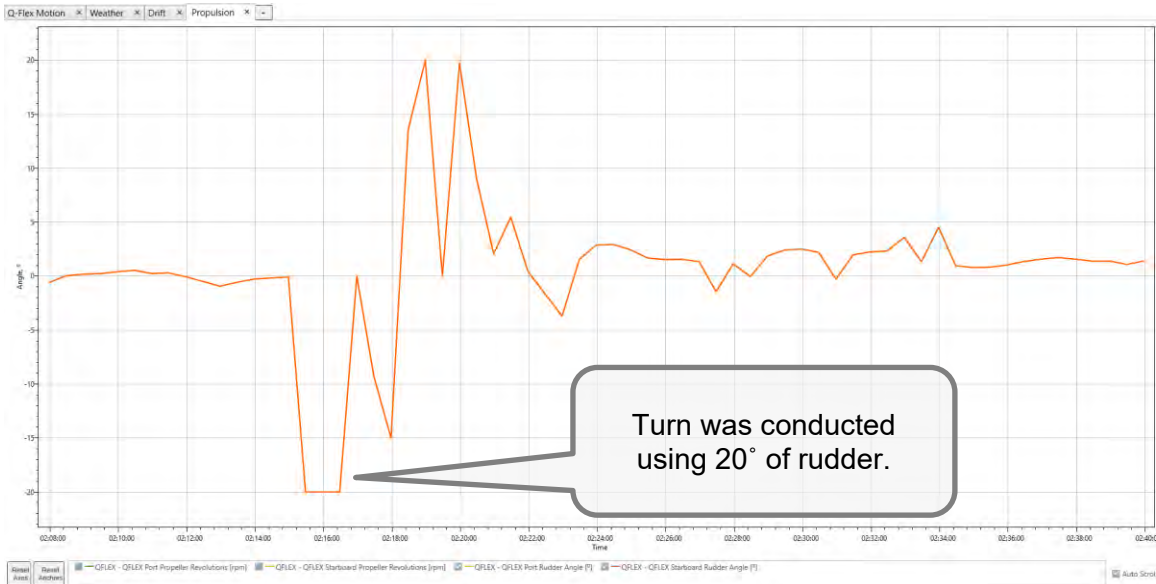
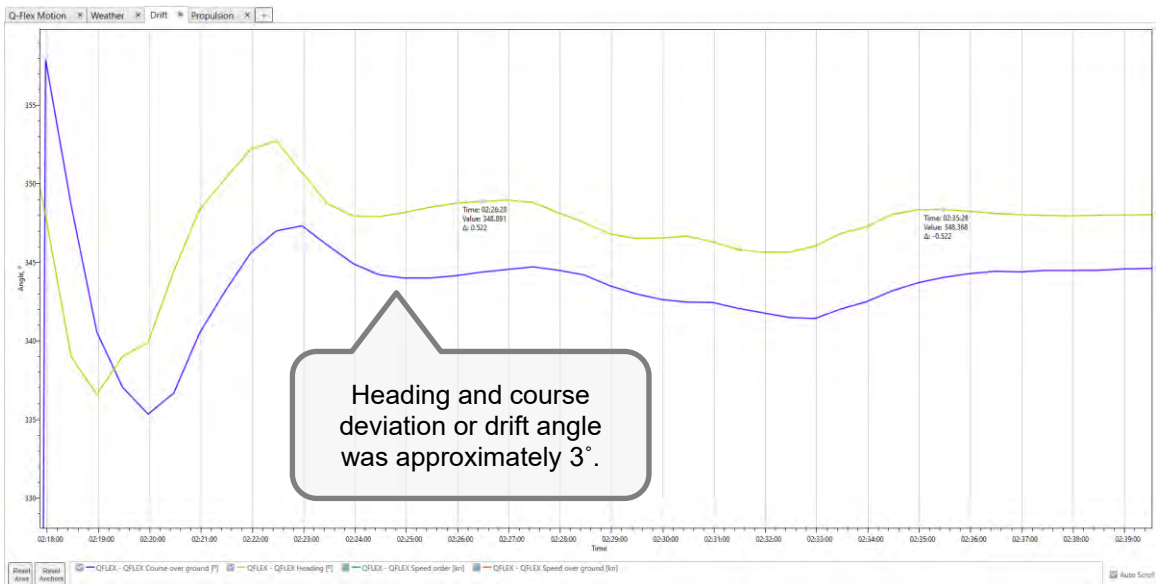

Figure 28: Heading and course differential on 343° course (R1-1)



4.2 Steering and Positional Control: Wind Limits

LNG carriers are prone to wind-induced rotation, especially when the wind is from a relative angle between 125° and 165° from the LNG carrier heading. To examine potential upper wind speed limits for the transit, a test was run with a loaded 217,000 m³ LNG carrier outbound between Beaver Rock and Triple Islands (the most constrained portion of the transit). Transit speed was taken as no more than 10 knots. The wind direction was set from the prevailing south-easterly quadrant at a speed of 15 knots, but then progressively increasing to a mean wind speed of 35 knots (18 m/s) during the first 10 minutes of the scenario. The engine telegraphs were again set at Half Ahead (10.3 knots water speed / set speed for the loaded ship). The tidal current was ebbing (outflowing) at approximately 1 knot.

Similar to the inbound transit, the 217,000 m³ LNG carrier's steering and positional control were good until the wind speed reached 30 knots. The ship was steadied slightly upwind of the course centreline with a drift angle of approximately 5°. As the wind speed climbed above 30 knots, progressively more starboard rudder had to be carried, and at a wind speed of 35 knots, the ship only generated a rate of turn of 1° to 2° per minute with the rudder at starboard 30° and the telegraphs at the Half Ahead position. To initiate the course alteration from the 264° course onto the 282° course the telegraphs were briefly ordered to Manoeuvring Full, and the 217,000 m³ LNG carrier then developed a turn rate of 8° per minute. The telegraphs were then once again set to Half Ahead, and the ship was steadied onto a heading of 276° to affect a course of 282°. When easing the starboard rudder to allow the ship to steady on a heading to port of the desired course over the ground, care had to be taken to ensure that the ship did not develop a strong port turn rate. With 35 knots of wind on the quarter, the 217,000 m³ LNG carrier was at the threshold of where it could maintain steering and positional control while maintaining a transit speed of 10 knots or less. See further explanations in Figure 29 to Figure 35 below:

Figure 29: Track-plot – Beaver Rocks to Triple Island, wind SE 35 (R1-2)



Figure 30: Track-plot – Passing Hammer Rocks, wind SE 35 (R1-2)

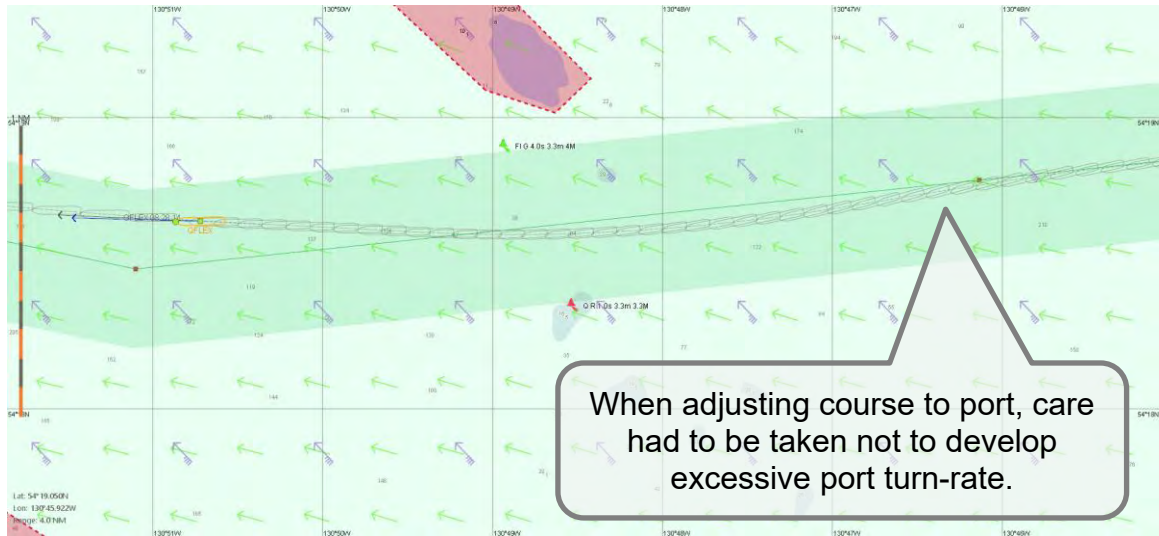

Figure 31: Rate of turn – Beaver Rocks to Triple Island, wind SE 35 (R1-2)

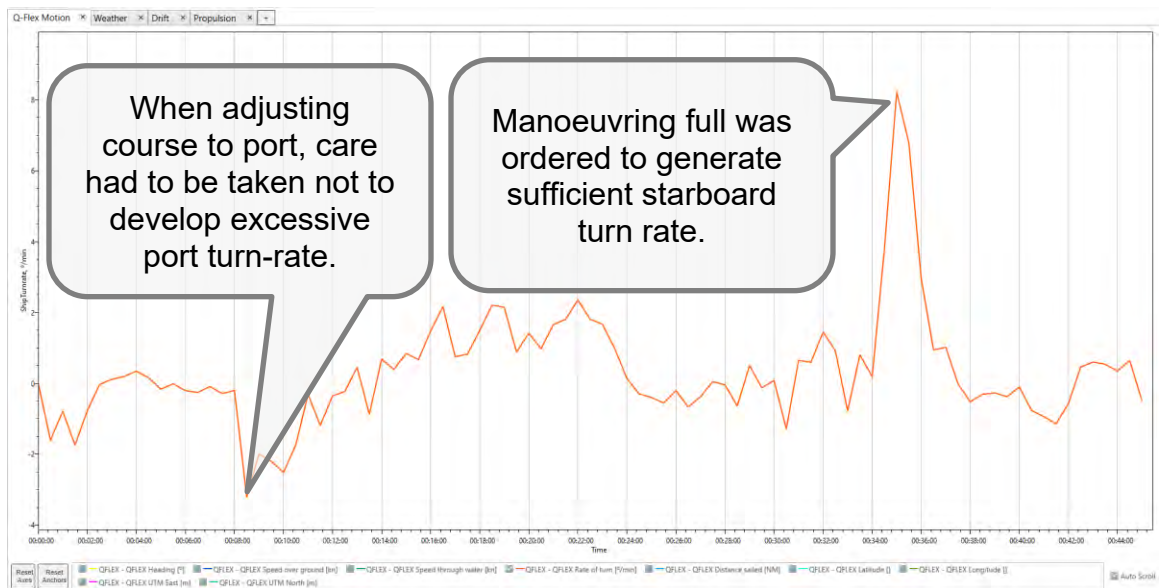

Figure 32: Heading vs course – Beaver Rocks to Triple Island, wind SE 35 (R1-2)

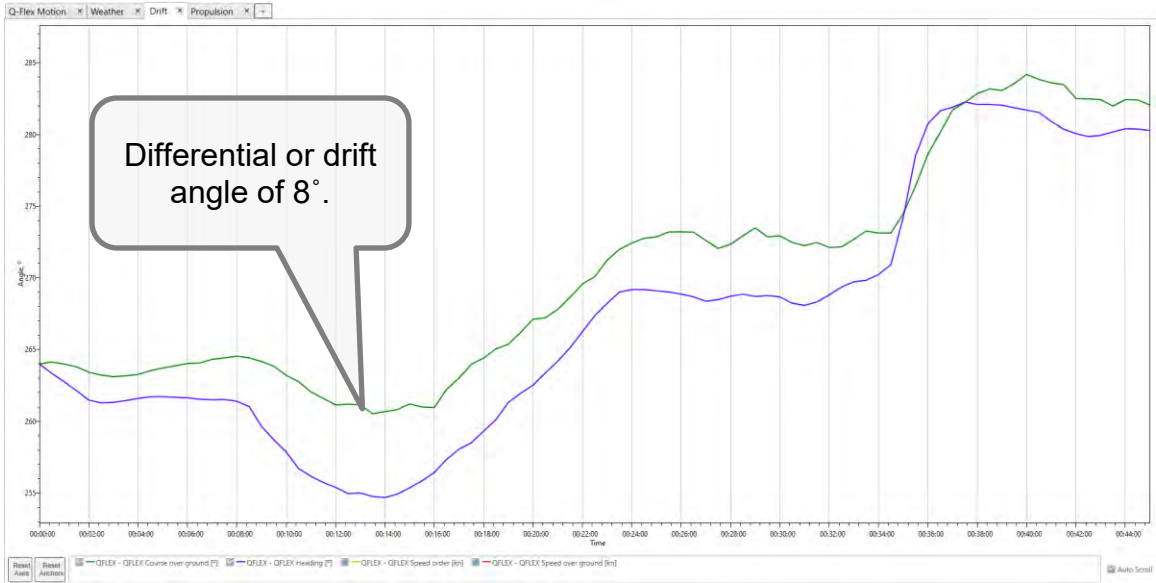
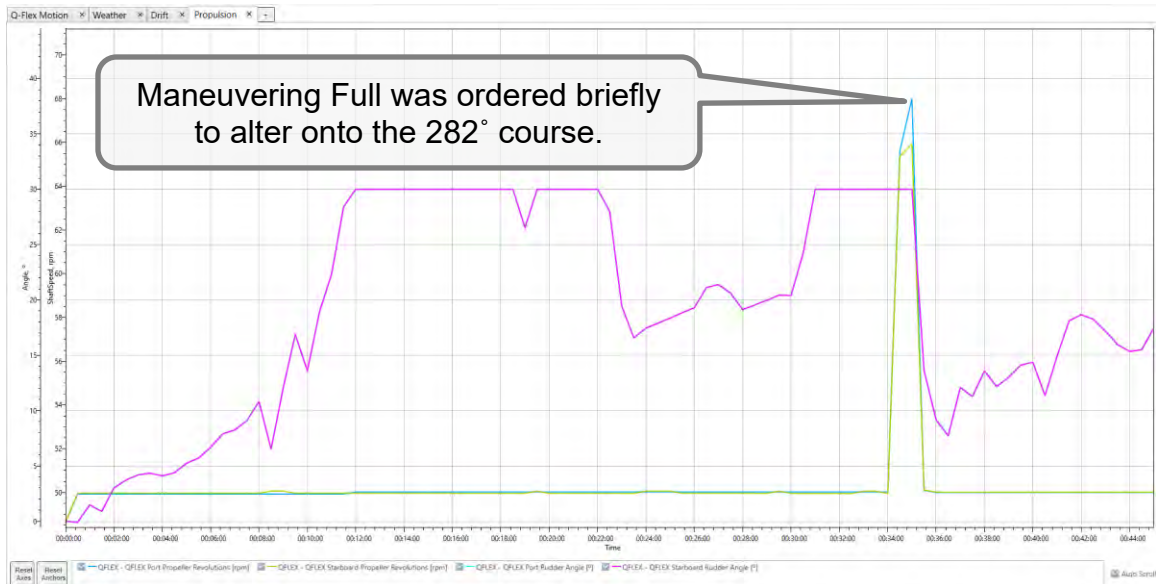

Figure 33: Wind vs rudder – Beaver Rocks to Triple Island, wind SE 35 (R1-2)



Figure 34: Rudder vs telegraph – Beaver Rocks to Triple Island, wind SE 35 (R1-2)



Having noted how steering control at 10 knots was reduced when the wind was on the quarter (relative angles from 125° to 165°) and at a speed greater than 35 knots (frequency of winds > 35 knots is only 5.5%). Runs were conducted in the western route segment with a transit speed of 14 knots and the engine telegraphs set to 64%. This increase in propeller speed generated significantly more steering force (water flow over the rudder) and the higher water speed translated into better vessel directional stability, making the ship less susceptible to wind-induced rotation and drift.

When inbound with northwest winds at 40 knots, the empty vessel, on the straight track legs the ship was navigated within one to two ship-widths of the track centreline without difficulty. The drift angle (difference between the heading [course steered] and the course made good [ground track]) was not more than 4°. With the wind on the port quarter, approximately 10° of starboard rudder was carried to hold course. The alteration from the 102° course to the 084° course was conducted with a large radius, in a slow sweeping manner such that the rate of turn did not exceed 5°/ minute. The larger alteration from the 084° course to the 025° course required a tighter radius turn. It was still conducted in a highly controlled manner with the turn rate not exceeding 16°/ minute and requiring no more than 10° rudder to steady the ship. See Figure 36 to Figure 40 below:

Figure 35: Track-plot – Pilot Station to Hanmer Rocks, wind NW 40 (R1-3)

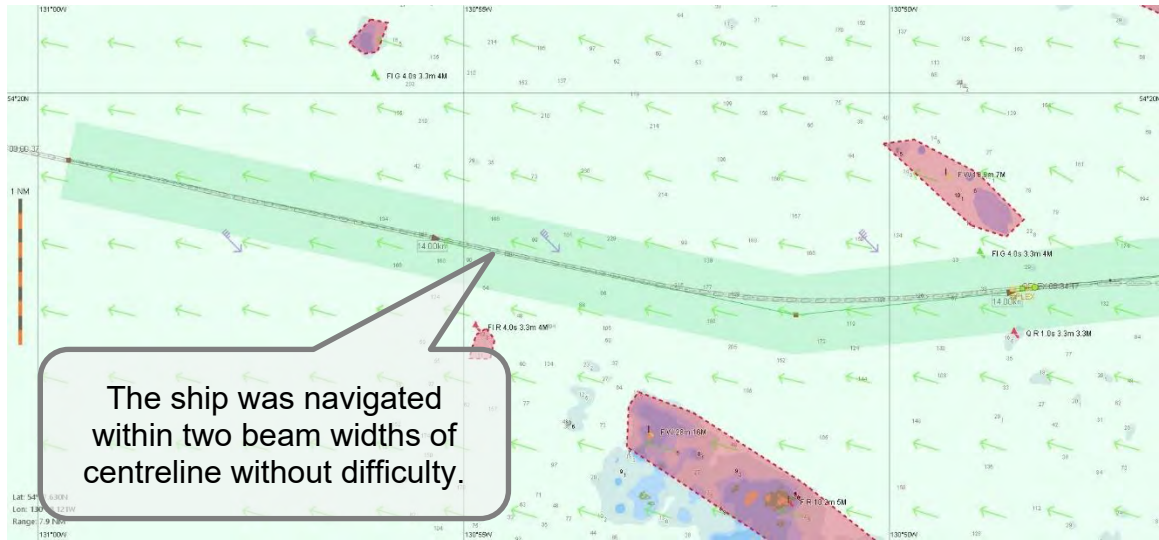

Figure 36: Track-plot – altering 102° to 084°, wind NW 40 (R1-3)

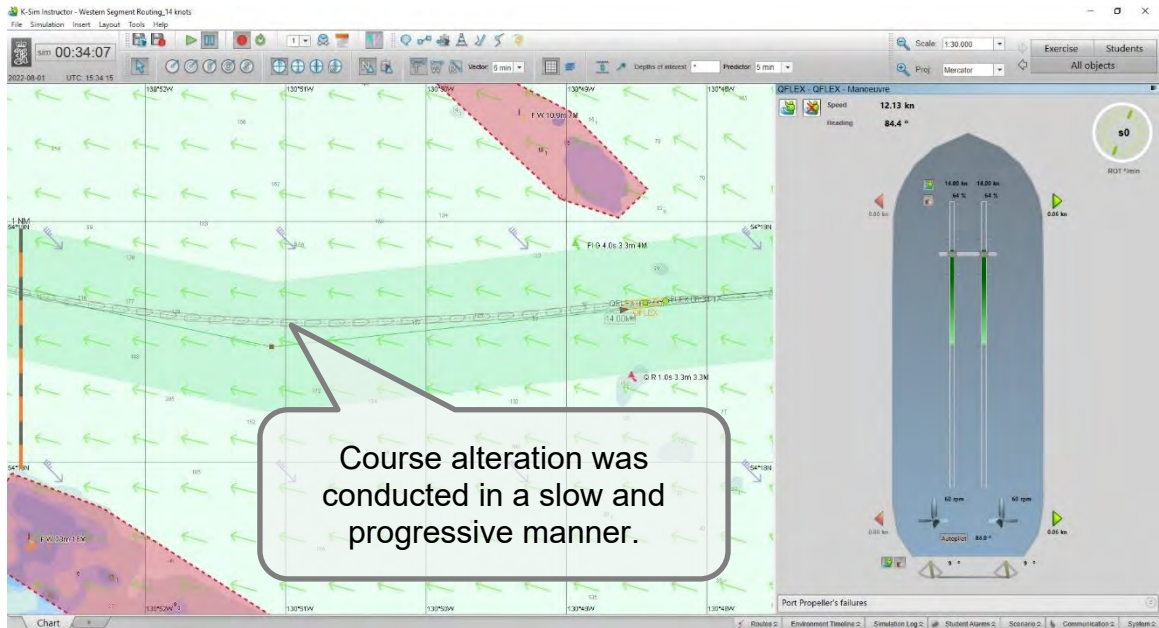

Figure 37: Track-plot – Hanmer Rocks to 025° course, wind NW 40 (R1-3)

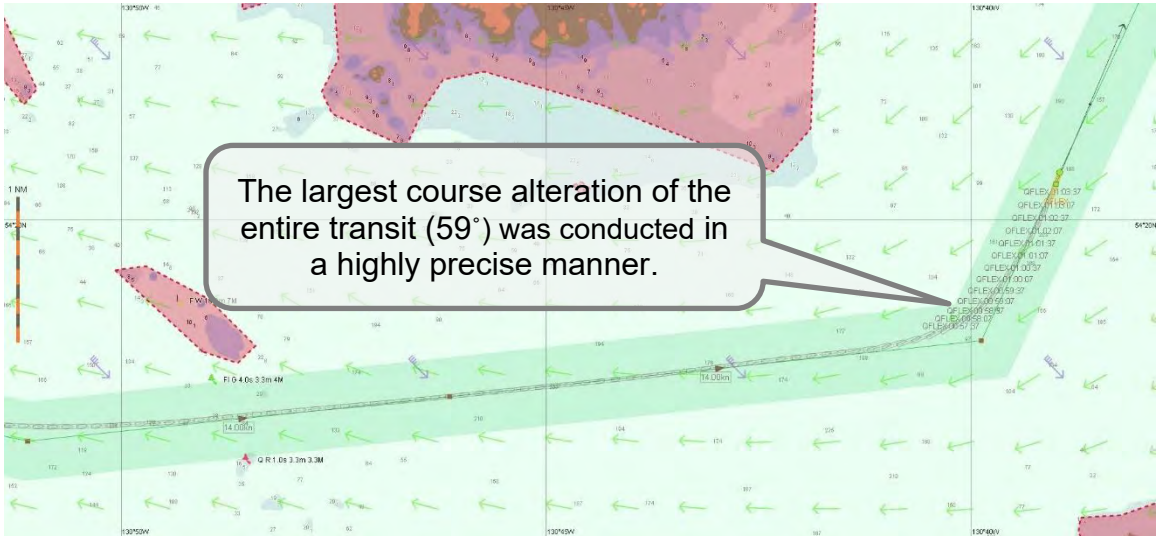

Figure 38: Drift angle – inbound LNGC, wind NW 40 (R1-3)

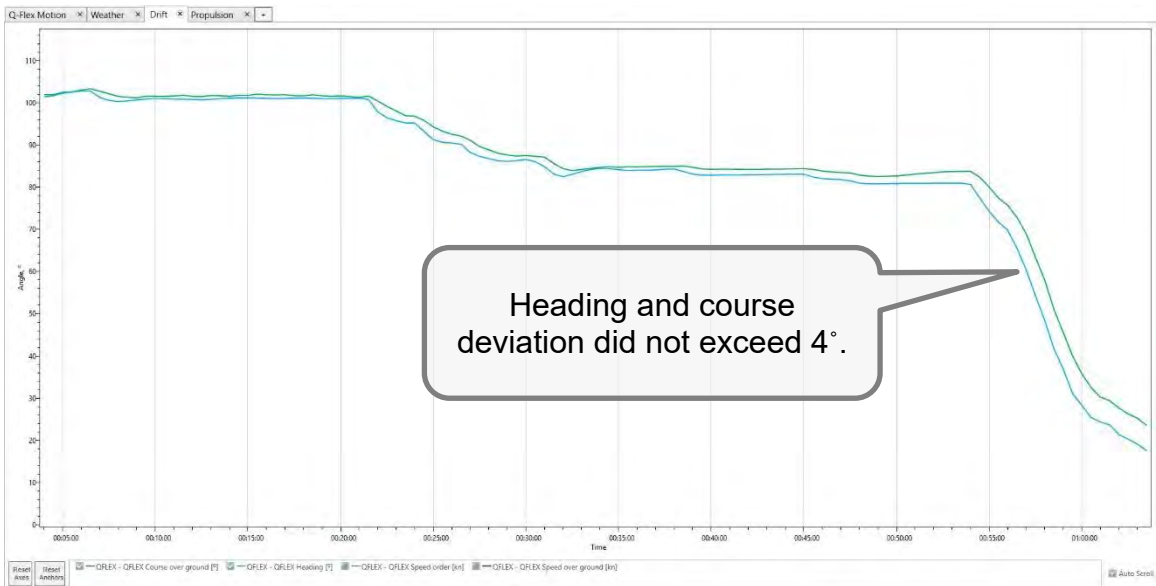

Figure 39: Applied rudder – inbound LNGC, wind NW 40 (R1-3)

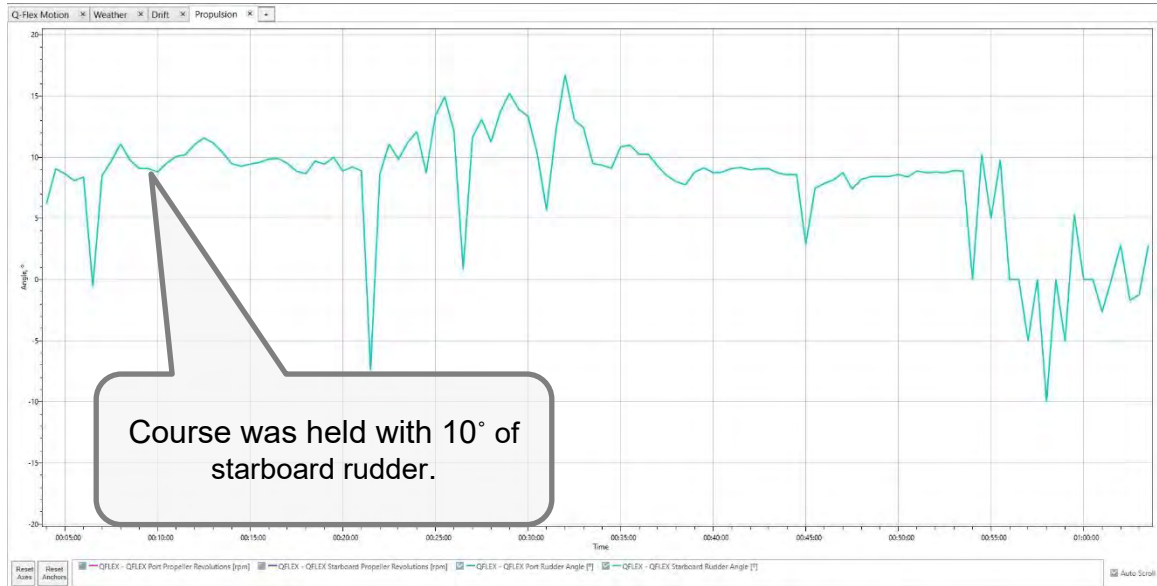

Figure 40: Rate of turn – inbound LNGC. Wind NW 40 (R1-3)



Results with the outbound loaded 217,000 m³ LNG carrier in 40 knot southeast winds were similar. On this run the southeast wind generated rotational resistance for the first turn from 205° to 264° and necessitated the application of 30° of starboard rudder to initiate the turn. A rate of turn of nearly 14° per minute was obtained and the ship conducted the turn in a controlled manner. Once steadied on the 264° course, the heading (course steered) varied from 259° to 262° to compensate for wind and tidal current induced drift carrying approximately 10° of starboard rudder to hold the course. The 217,000 m³ LNG carrier was navigated within two ship-widths of the track centreline throughout the outbound transit. See Figure 41 to Figure 47 below:

Figure 41: Track-plot – 205° course to Hammer Rocks, wind SE 40 (R1-4)



Figure 42: Track-plot – outbound Goal Posts, wind SE 40 (R1-4)



Figure 43: Track-plot – Hanmer Rocks to Pilot Station, wind SE 40 (R1-4)

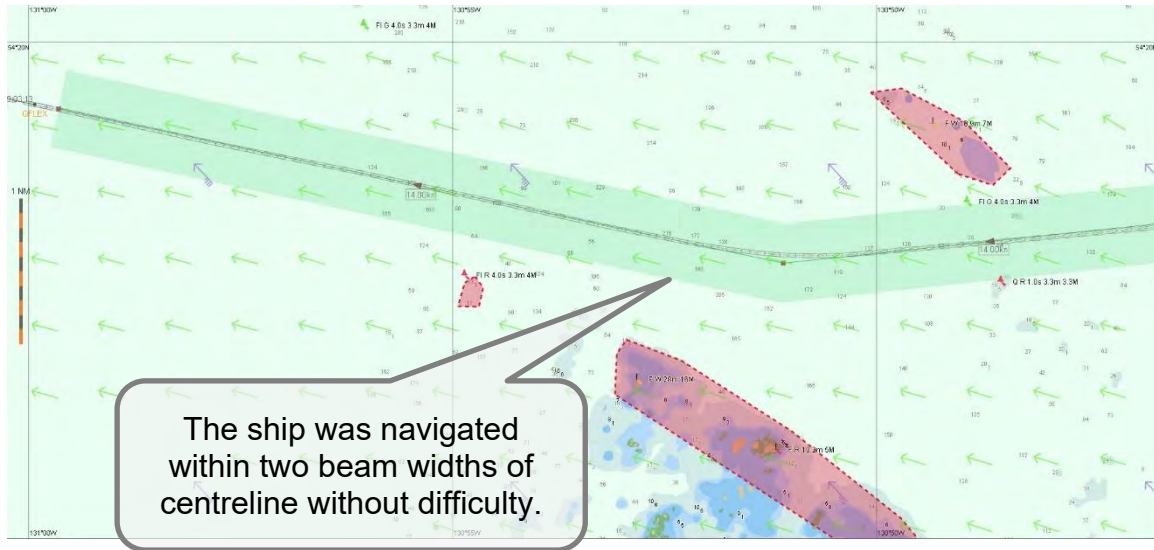

Figure 44: Drift angle – outbound LNGC, wind SE 40 (R1-4)

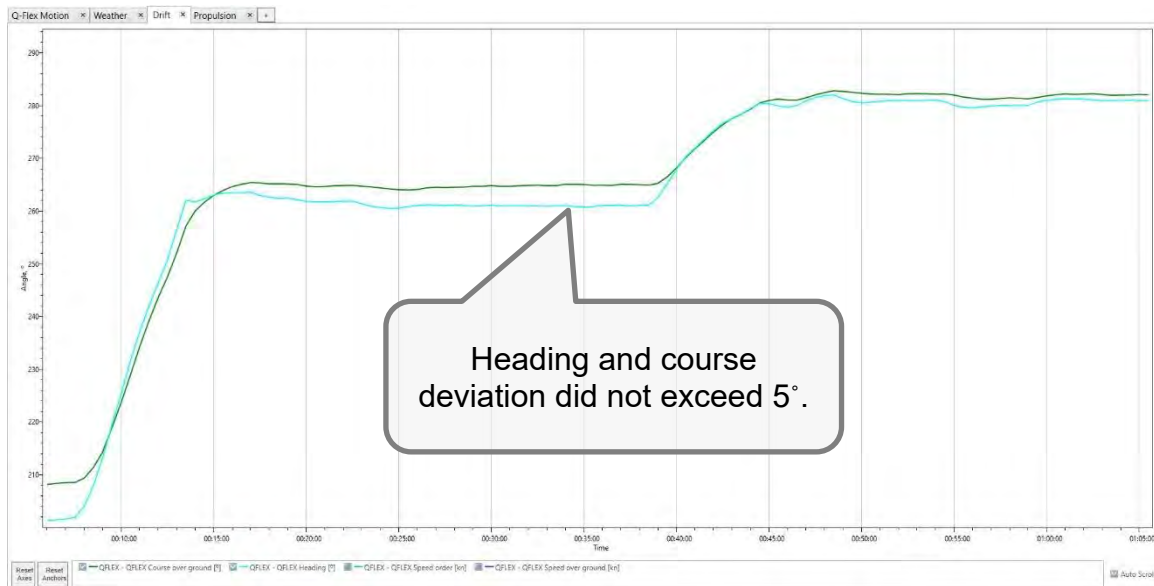

Figure 45: Applied rudder – outbound LNGC, wind SE 40 (R1-4)

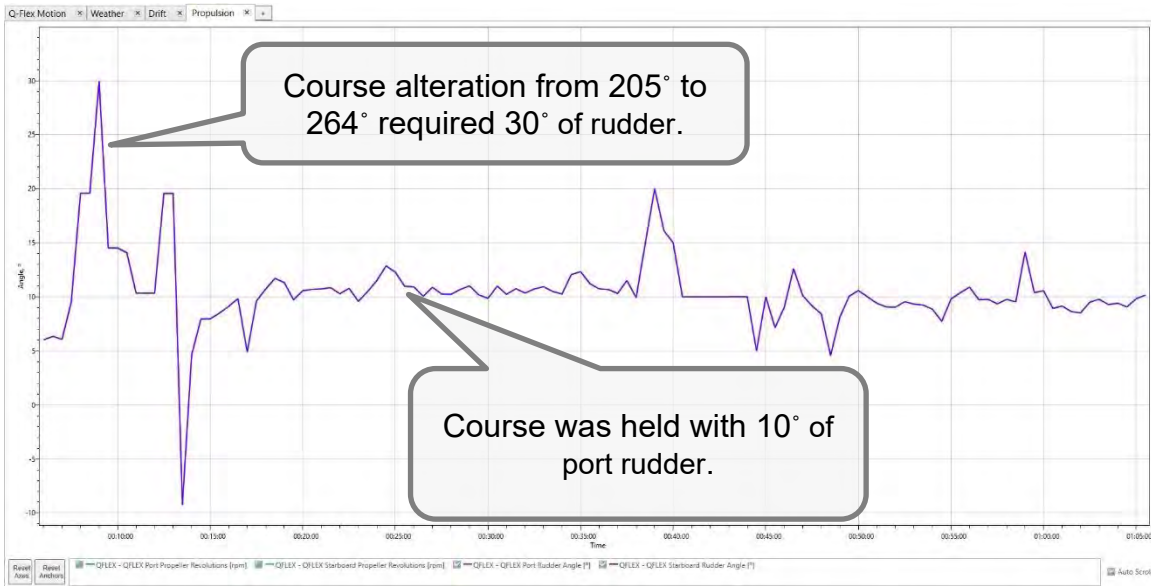
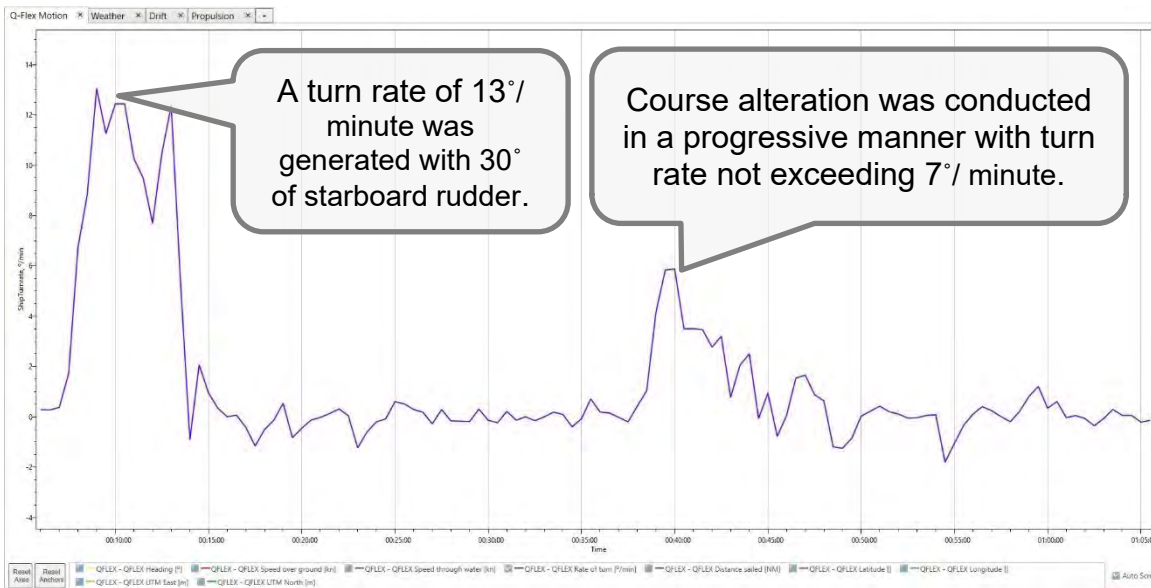

Figure 46: Rate of turn – outbound LNGC, wind SE 40 (R1-4)



When the wind speed was increased to NW 50 knots the inbound empty 217,000 m³ LNG carrier was still navigated within 3 ship-widths of the marine route centreline. Upwards of 20° of rudder were needed to hold course, and when steadying onto the 084° course two kicks of Manoeuvring Full were used to counter the wind-induced rotation. It should be underlined that wind from any direction has only exceeded 47 knots (24 m/s) with a frequency of occurrence of 0.49% and has never been recorded in the northwest or southwest quadrant. As such this test was considered purely as an examination of manoeuvring limits in Brown Passage as opposed to a scenario which should be considered a plausible real-world operational requirement. See Figure 47 to Figure 52 below:

Figure 47: Track-plot – Pilot Station to Hammer Rocks, wind NW 50 (R1-5)

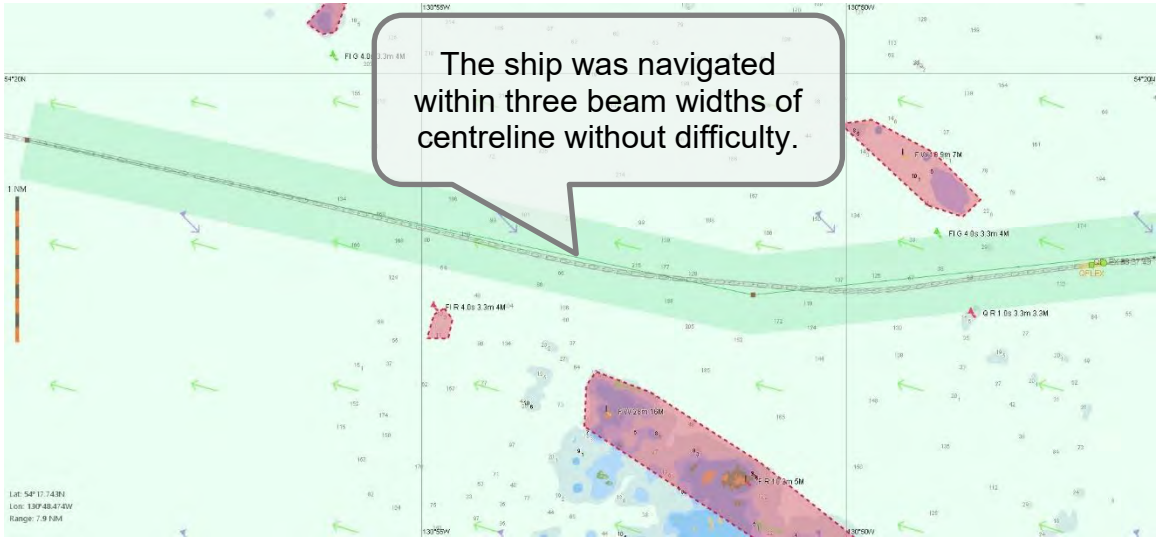

Figure 48: Track-plot – altering 102° to 084°, wind NW 50 (R1-5)

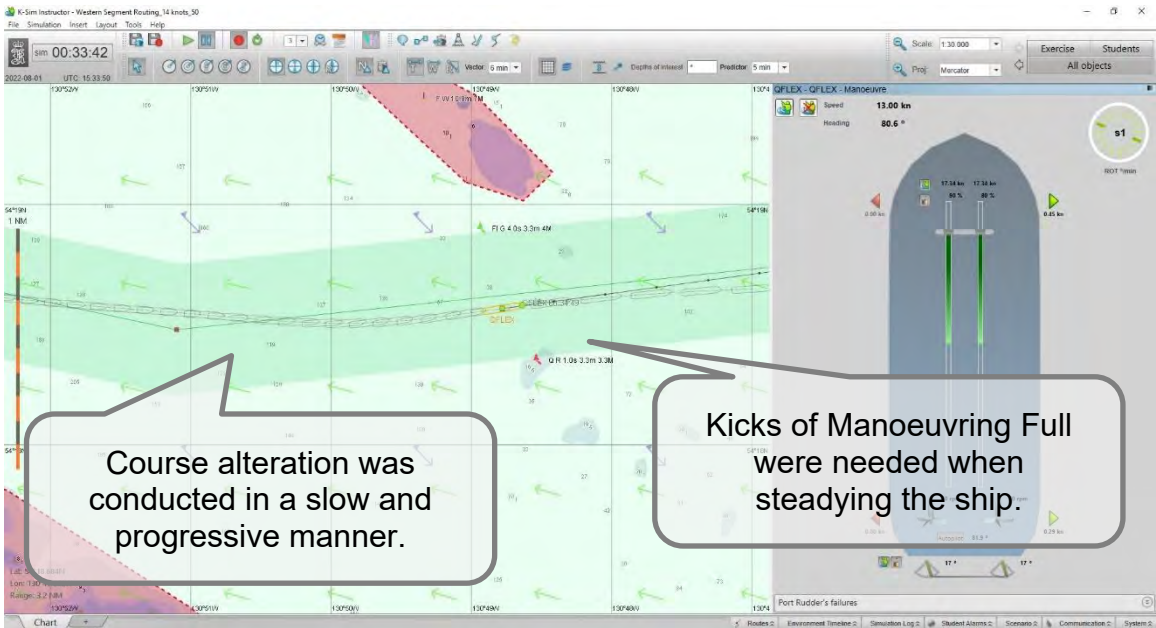

Figure 49: Track-plot – Hanmer Rocks to 025° course, wind NW 50 (R1-5)

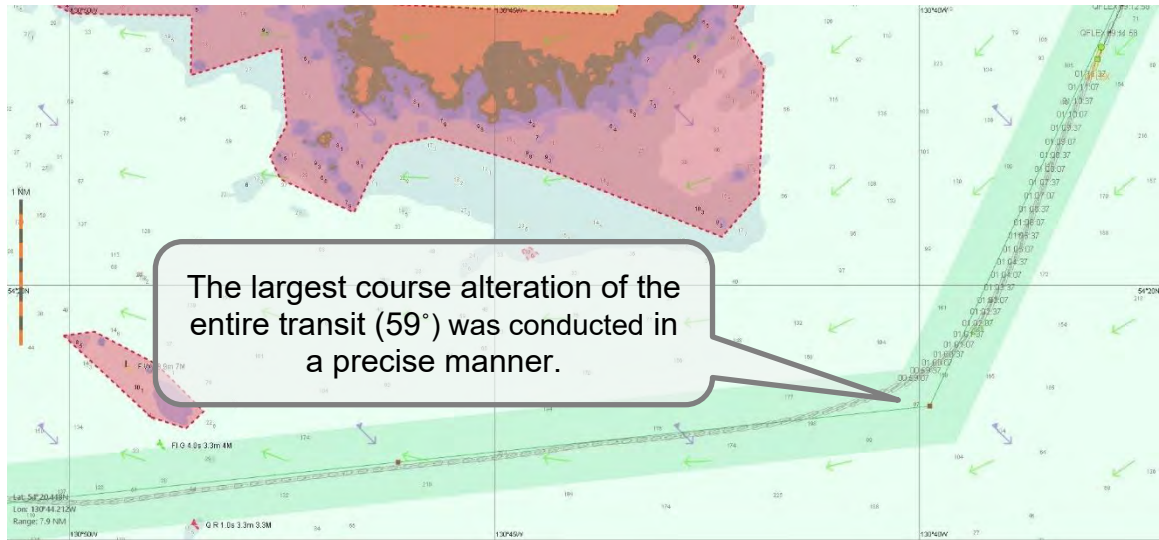

Figure 50: Drift angle – inbound LNGC, wind NW 50 (R1-5)



Figure 51: Applied rudder – inbound LNGC, wind NW 50 (R1-5)

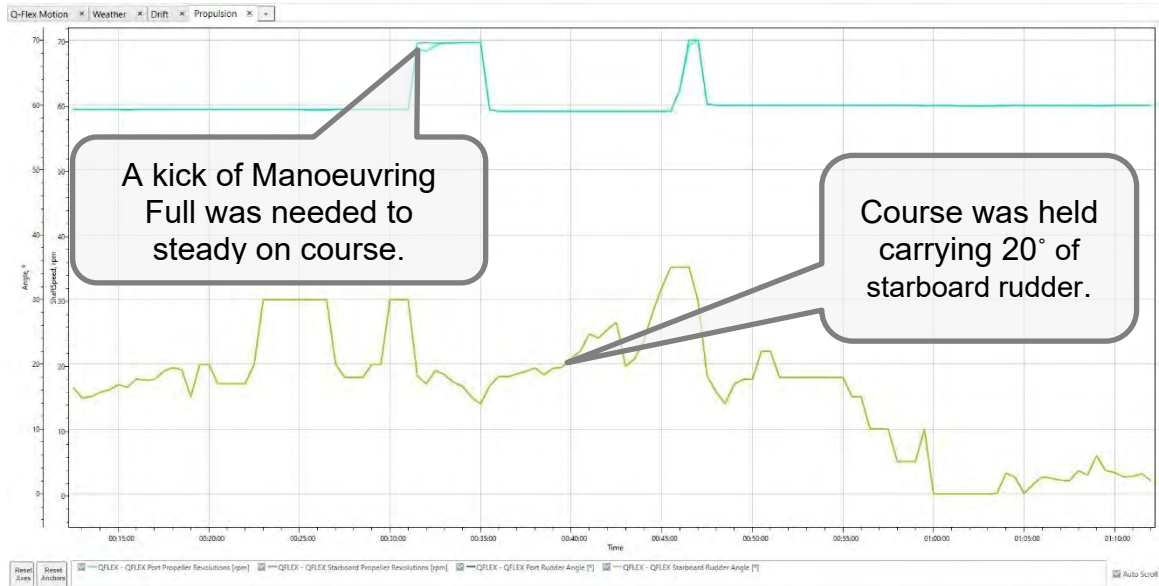
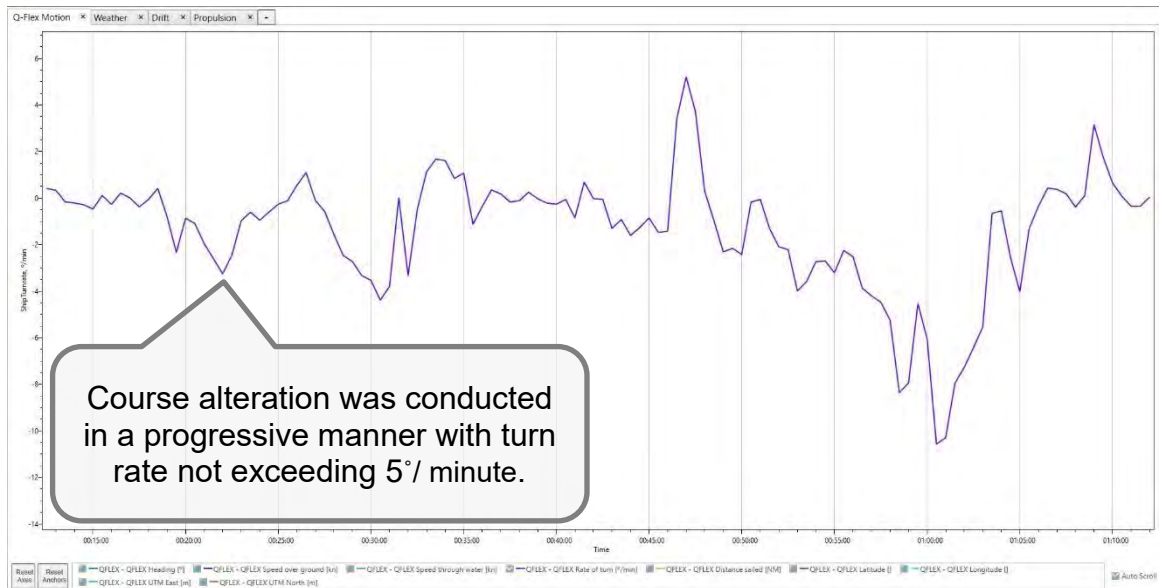

Figure 52: Rate of turn – inbound LNGC, wind NW 50 (R1-5)



Results with the outbound loaded 217,000 m³ LNG carrier in 50 knot southeast winds were similar. In this case the relative wind angle on the 264° and 282° track segments was the credible worst-case for producing wind-induced rotation, and the telegraph had to be ordered to Manoeuvring Full to hold course. Once this was done, the ship was still navigated in a controlled manner within four ship-widths of the marine route centreline. Winds more than 50 knots in the region have only been recorded from the northeast and southeast quadrants, and the recorded frequency of these winds in the southeast octant is only 0.023%. Again, this test condition should be considered as a measurement of manoeuvring limits in Brown Passage as opposed to a scenario which should be considered a plausible real-world operational requirement. See Figure 53 to Figure 58 below:

Figure 53: Track-plot – 205° course to Hanmer Rocks, wind SE 50 (R1-6)

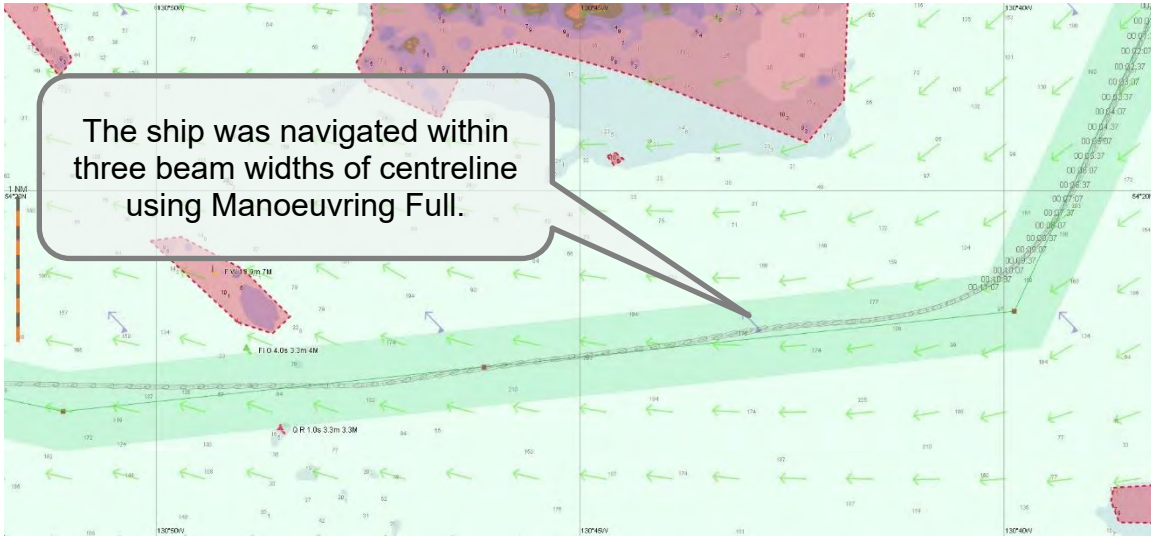

Figure 54: Track-plot – outbound steading 264, wind SE 50 (R1-6)

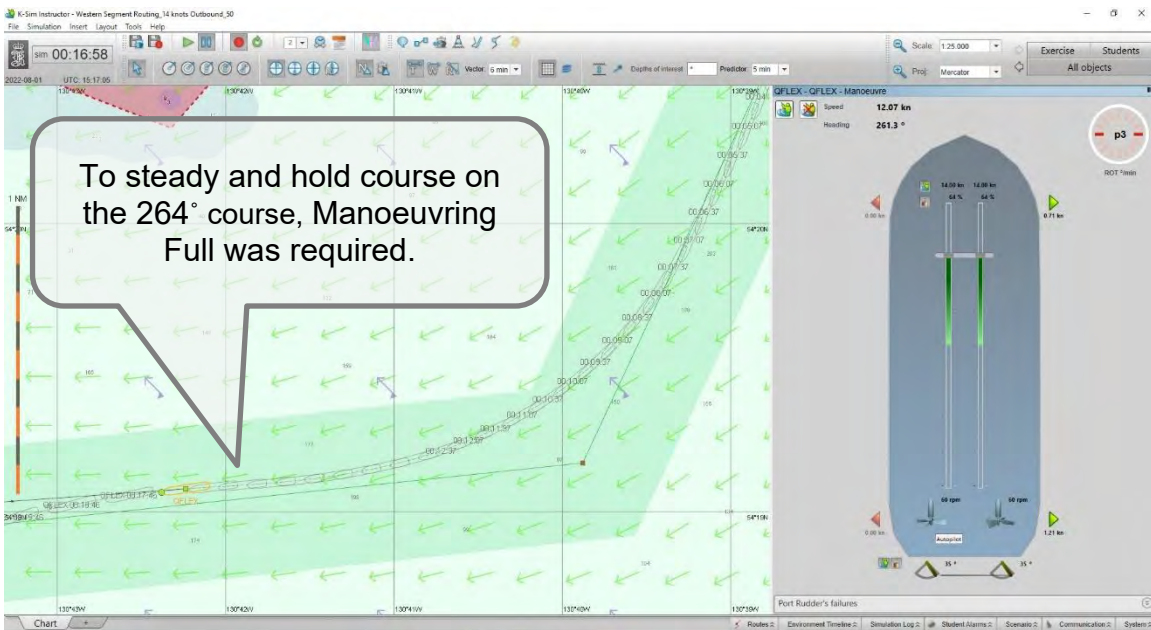

Figure 55: Track-plot – Hanmer Rocks to Pilot Station, wind SE 50 (R1-6)



Figure 56: Drift angle – outbound LNGC, wind SE 50 (R1-6)

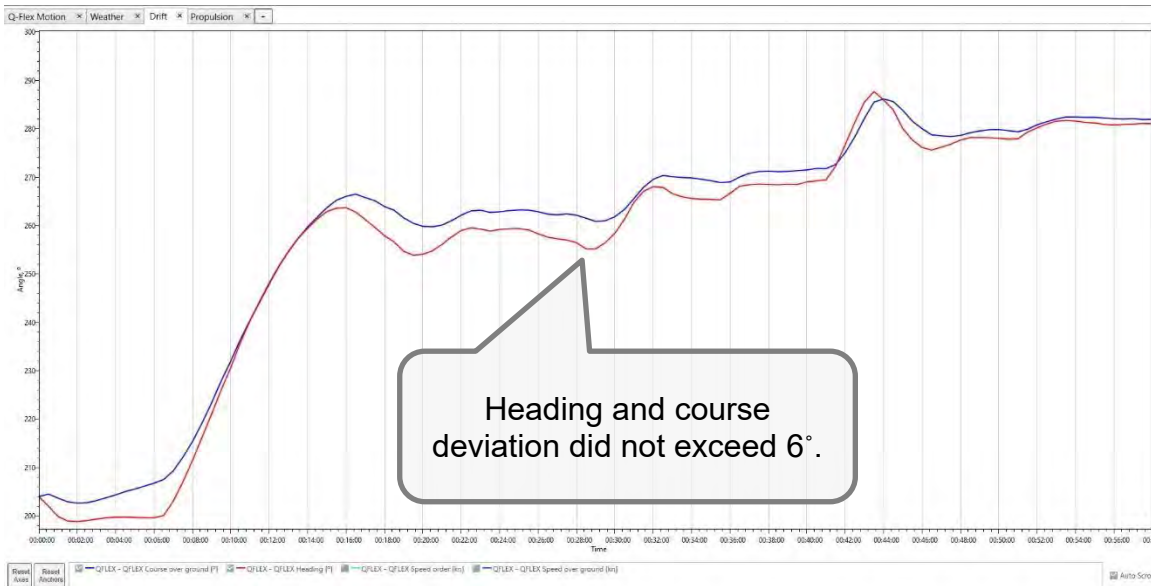
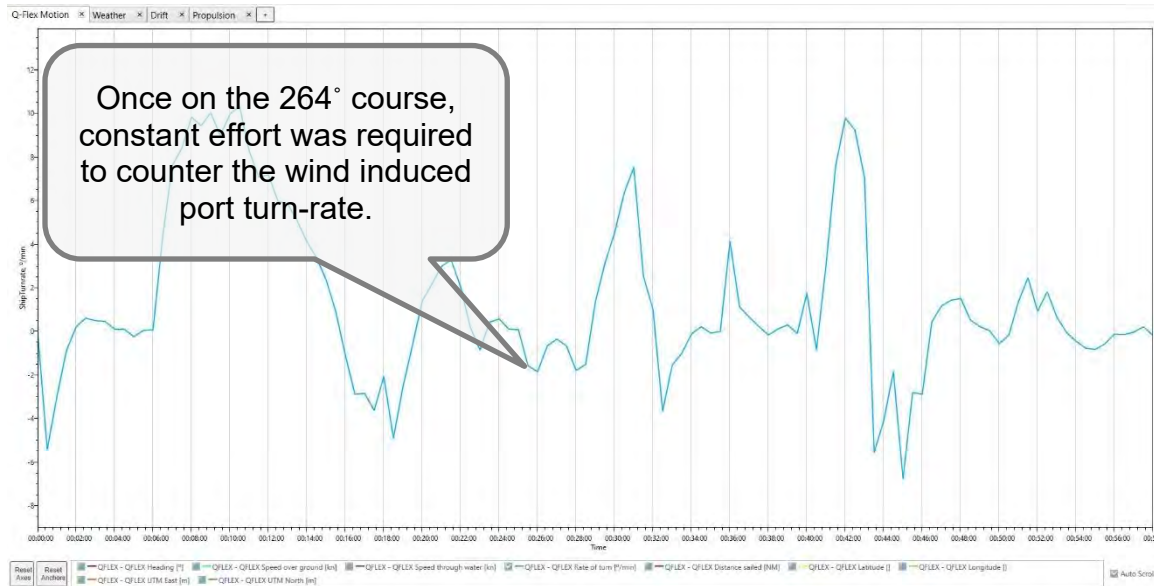

Figure 57: Applied rudder – outbound LNGC, wind SE 50 (R1-6)



Figure 58: Rate of turn – outbound LNGC, wind SE 40 (R1-6)



A similar manoeuvring limits test was conducted with the NGL product vessel in the western route segment. In this case, with a relatively small vessel, vessel motion in waves is more of a concern than wind-induced rotation, so the maximum wind test speed was set to 40 knots. Also, with the wind and waves on the quarter, these small vessels tend to yaw considerably as part of their natural motion on the waves. Positional control at 14 knots with the telegraph in the corresponding Manoeuvring Full position was good with perpetual heading oscillation around the ordered course due to wave induced yaw. Both when inbound empty and outbound loaded, small rudder angles were constantly applied as a function of steering the desired course and the two course alterations were affected with relative ease. See Figure 59 to Figure 68 below:

Figure 59: Track-plot – Pilot Station to Hanmer Rocks, wind NW 40 (R1-7)

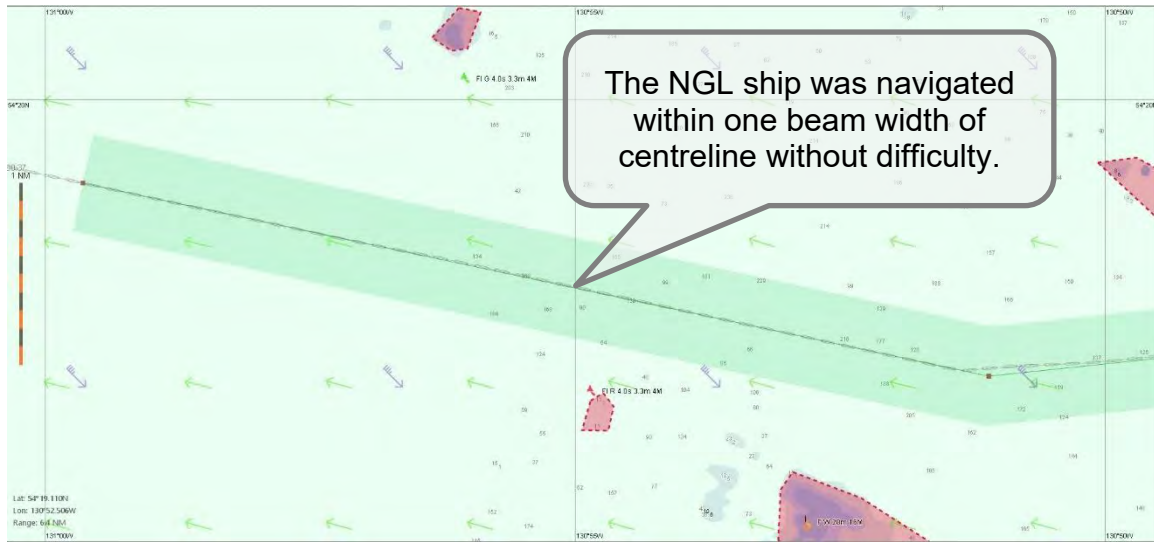

Figure 60: Track-plot – Hanmer Rocks to 025° course, wind NW 40 (R1-7)

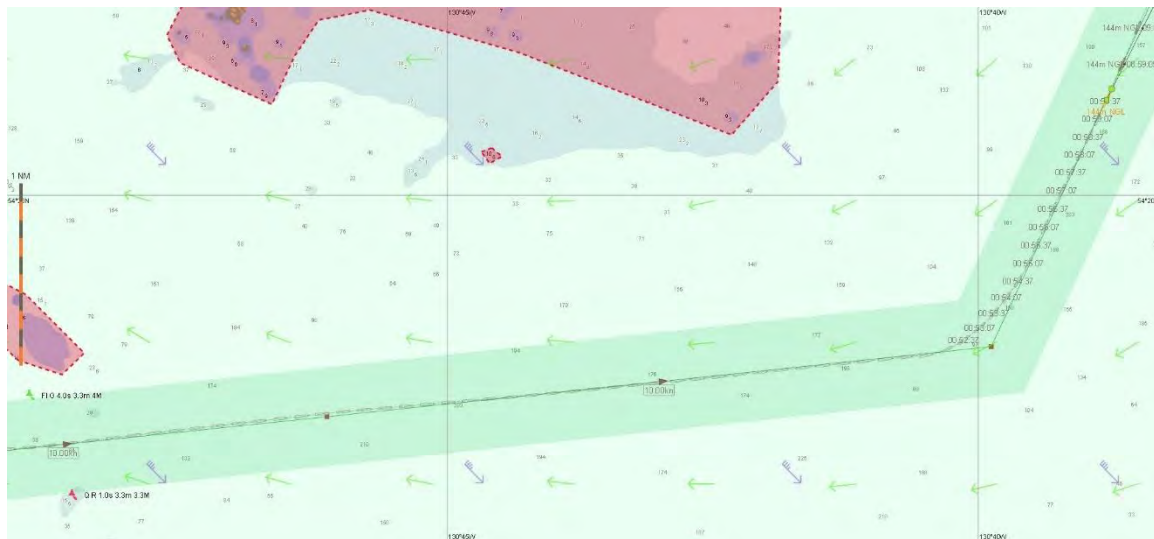

Figure 61: Drift angle – inbound NGL product vessel, wind NW 40 (R1-7)

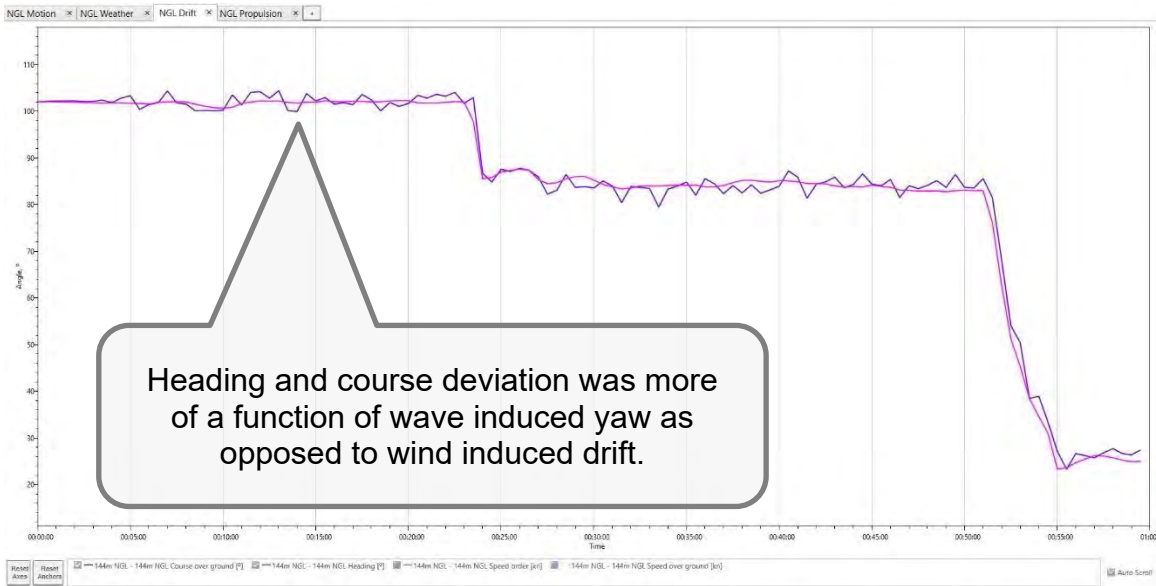

Figure 62: Applied rudder – inbound NGL product vessel, wind NW 40 (R1-7)

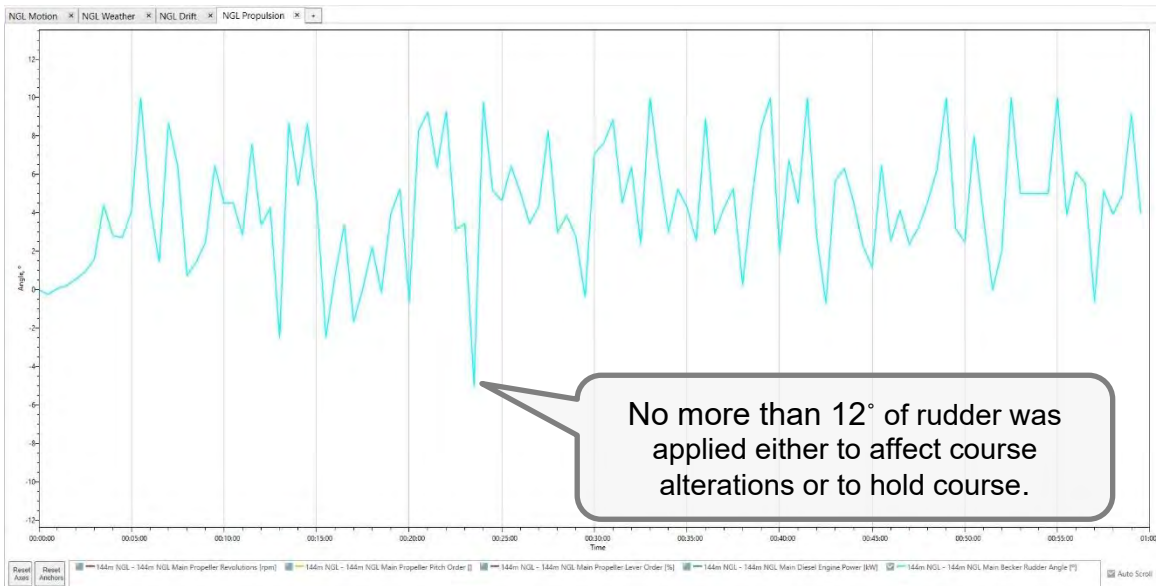

Figure 63: Rate of turn – inbound NGL product vessel, wind NW 40 (R1-7)

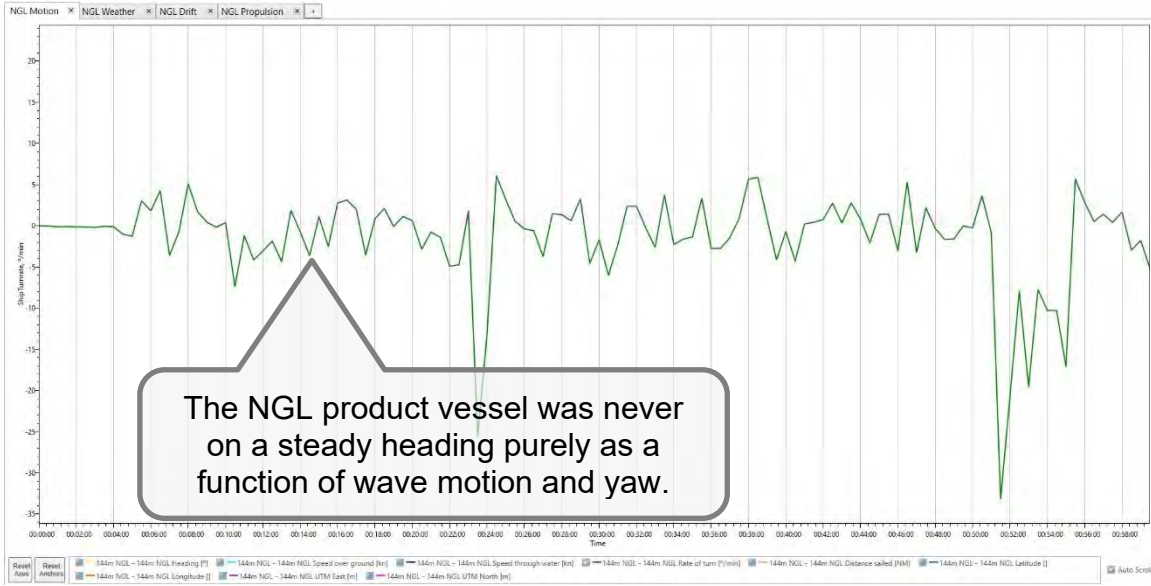

Figure 64: Track-plot – 205° course to Hanmer Rocks, wind SE 40 (R1-8)

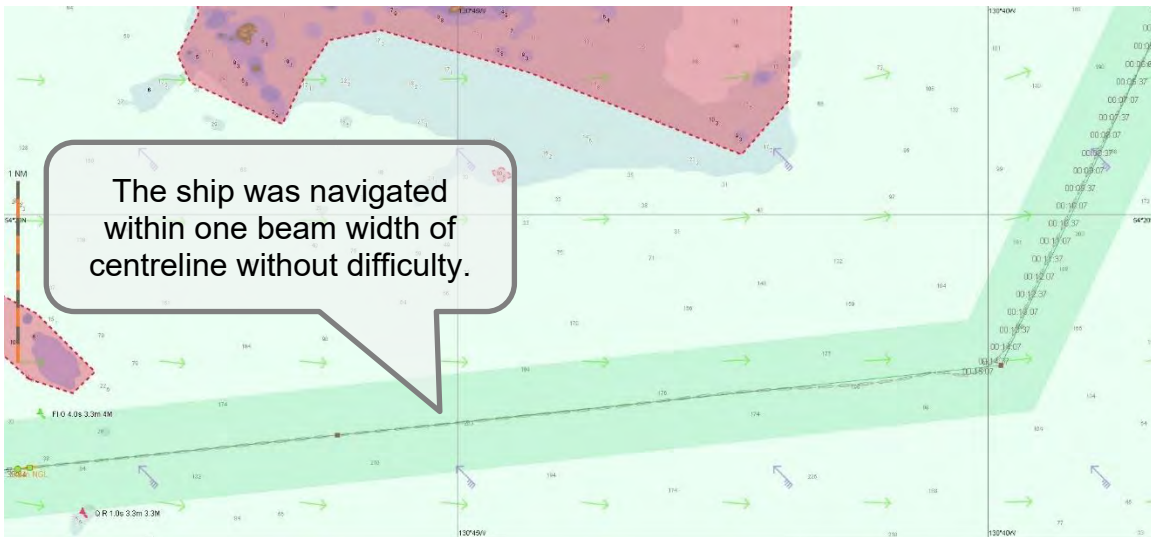

Figure 65: Track-plot – outbound Goal Posts, wind SE 40 (R1-8)

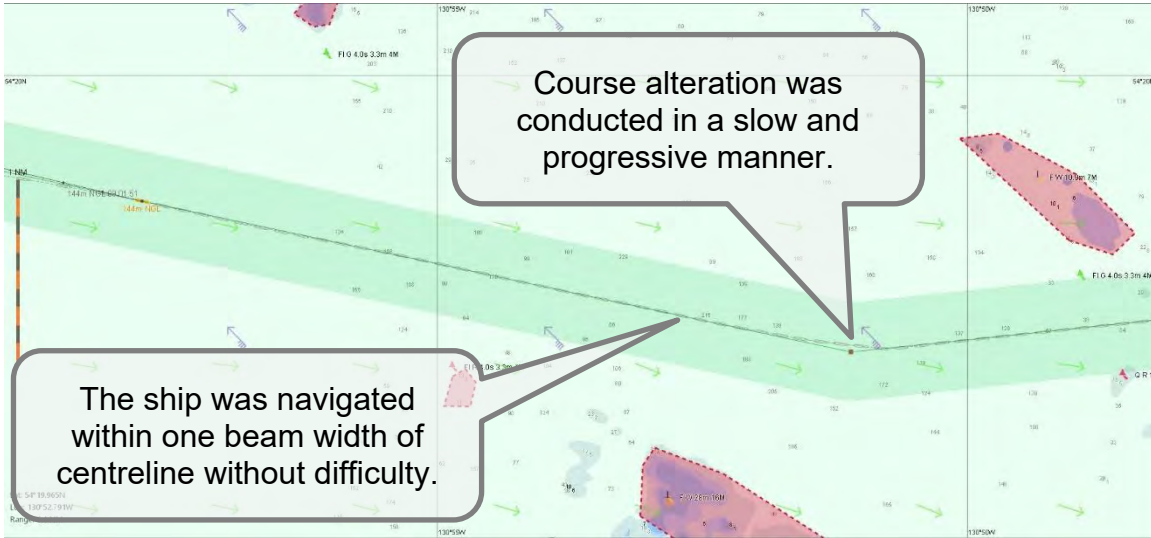

Figure 66: Drift angle – outbound NGL product vessel, wind SE 40 (R1-8)

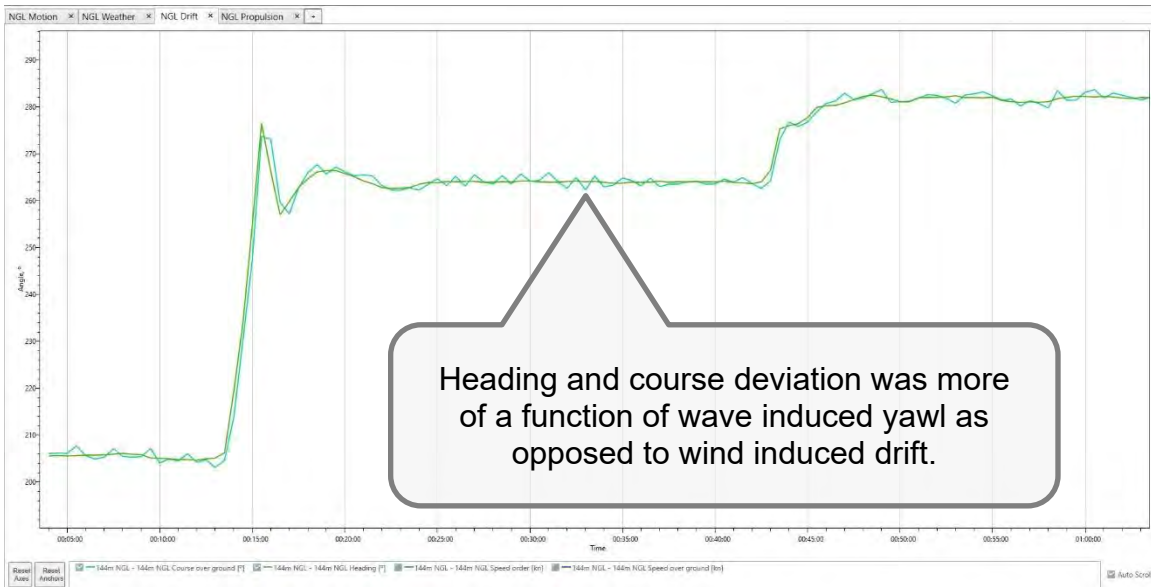

Figure 67: Applied rudder – outbound NGL product vessel, wind SE 40 (R1-8)

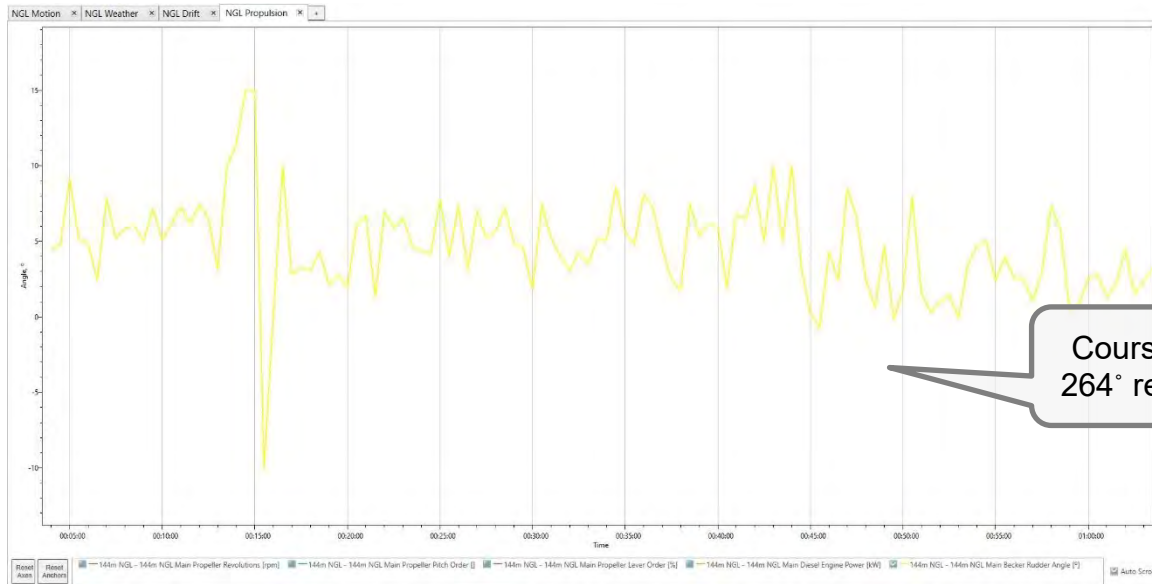
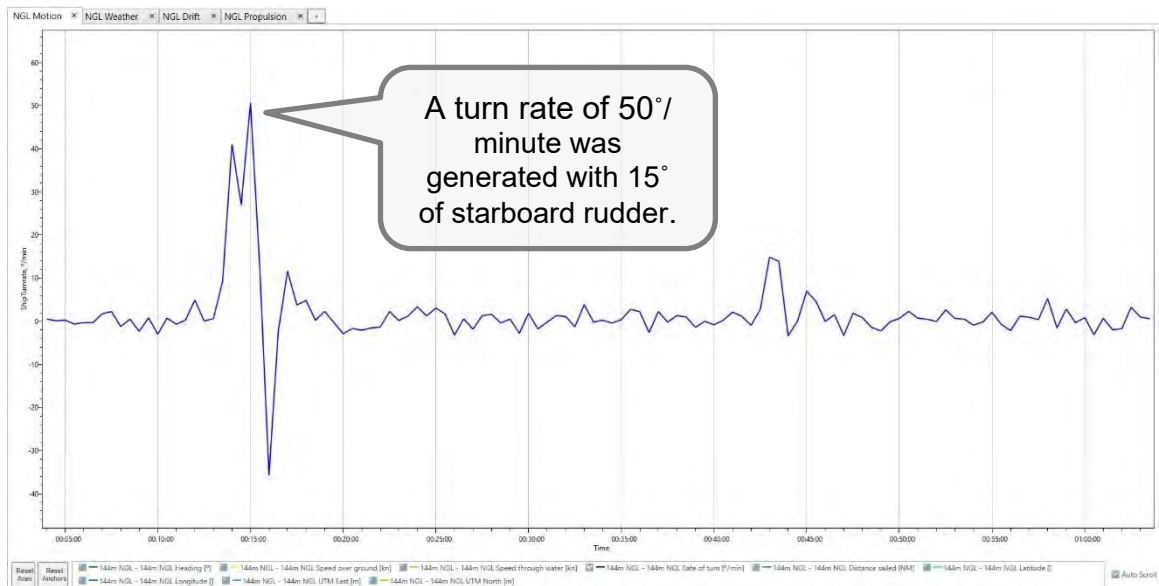

Figure 68: Rate of turn – outbound NGL product vessel, wind SE 40 (R1-8)



4.3 Turning Through and Holding in Extreme Wind

The Study considered the possibility of a LNG carrier having to hold position while waiting to berth, or to transit the navigationally constrained segments. It has been noted that winds stronger than 30 knots begin to make course holding more difficult, and the same holds true for turning the broadside and quarter of the ship through the wind. At lower speeds, when very strong winds are on the beam of the 217,000 m³ LNG carrier, the vessel (like a sailing ship) becomes “caught in irons” and will start to rotate back into the wind or will simply accelerate in a straight line. To ascertain options for either turning through, or holding in strong winds, several scenarios were tested where extreme outflow winds of 50 knots developed when the ship was approaching the end of Portland Inlet near the junction

point with the Portland Canal. It should be underlined this series of tests were conducted to evaluate pure manoeuvring capability in extreme conditions. Although it is sometimes difficult to forecast the exact speed of katabatic winds, it is possible to forecast the conditions when extreme outflow winds are most likely to occur. It should also be emphasized that the duration of these extreme conditions is typically measured in minutes versus hours, however the simulation tests illustrate that it is possible for a 217,000 m³ LNG carrier to hold position even without tug assistance for a prolonged period if it needed to.

In the first scenario, it was attempted to turn the ship using a typical technique of reducing speed until steering control was nearly lost, and then the rudders were ordered hard to port (45° for a 217,000 m³ LNG carrier) and then the telegraphs were ordered to Manoeuvring Full Ahead. This test was conducted primarily to determine the magnitude of the “caught in irons” effect, and to ascertain how much space would be needed to employ this method. Initially the ship started to turn rapidly to port with the rate of turn achieving 25° per minute, however as the ship rotated with the wind angle on the beam and then abaft the beam the turn rate slowed dramatically, and the ship started to gain considerable forward speed. Additionally, the full rudder angle of 45° is intended only for low-speed manoeuvring. With the rudder left at this angle, some rudder stall was also experienced, and the net result was that the transfer (distance in the perpendicular to the original heading) was more than 2.3 nautical miles. This manoeuvre was considered an unacceptable way to turn as for an extended period the ship was effectively stalled on a course taking it directly towards the lee shore at a speed over 10 knots. However, this manoeuvre could be conducted in the open areas of Chatham Sound if the decision was made to hold for weather. See Figure 69 to Figure 71 below:

Figure 69: Track-plot – turning stern through 50 knot winds (R1-9)

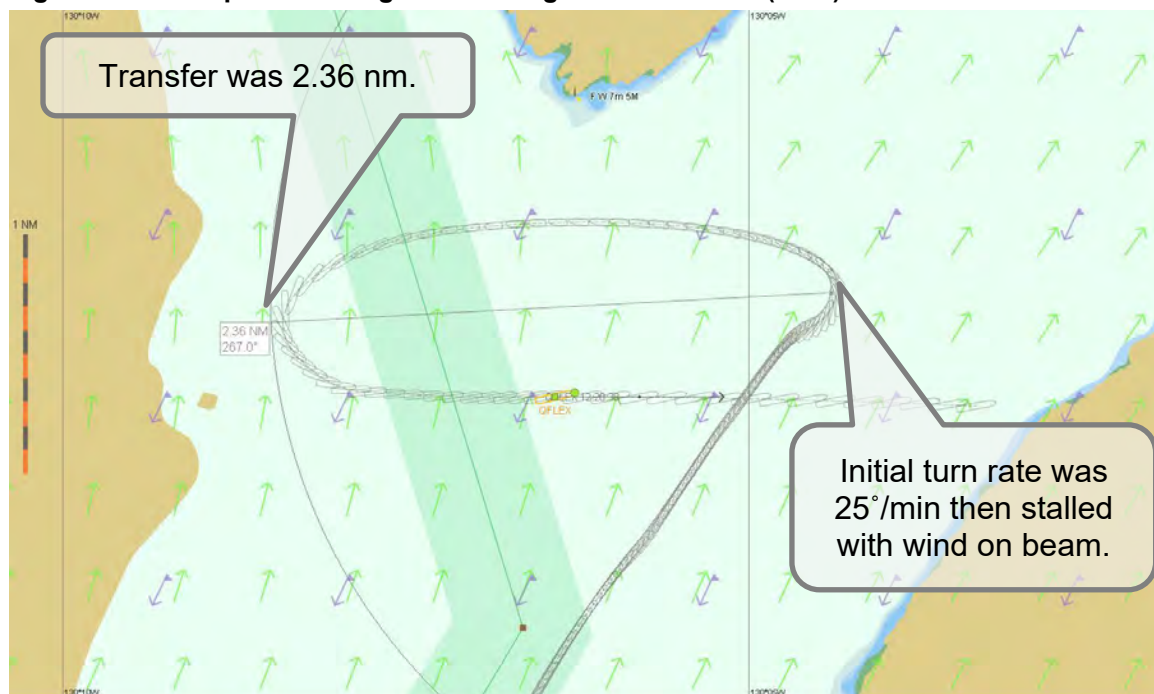
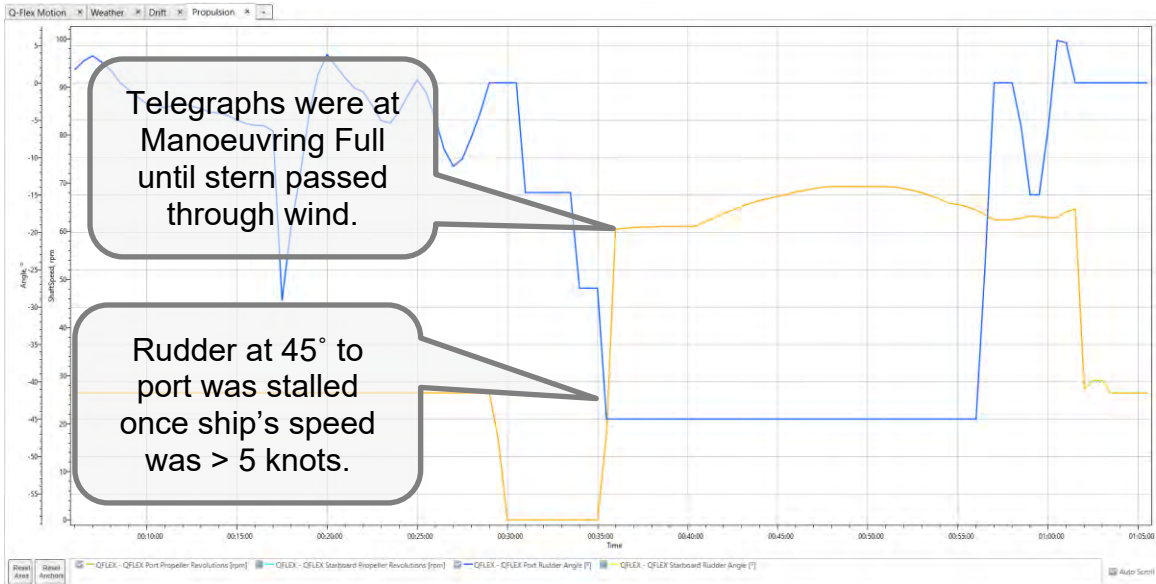

Figure 70: Rate of turn – turning stern through 50 knot winds (R1-9)



Figure 71: Rudder and RPM – turning stern through 50 knot winds: (R1-9)



This manoeuvre was repeated, however on the second attempt, once the ship reached a speed of 5 knots, the rudder was eased to 30°. Although the turn rate slowed markedly, it did not fall below 5° per minute, and the transfer was reduced considerably to 1.84 miles and the lee shore passed at a safe distance. It was assessed this manoeuvre was less than ideal, as it provided little margin for error, and Manoeuvring Full was ordered for 18 minutes. This technique would however work well in most of Chatham Sound if needed. See Figure 72 to Figure 74 below:

Figure 72: Track-plot – turning stern through 50 knot winds (R1-10)

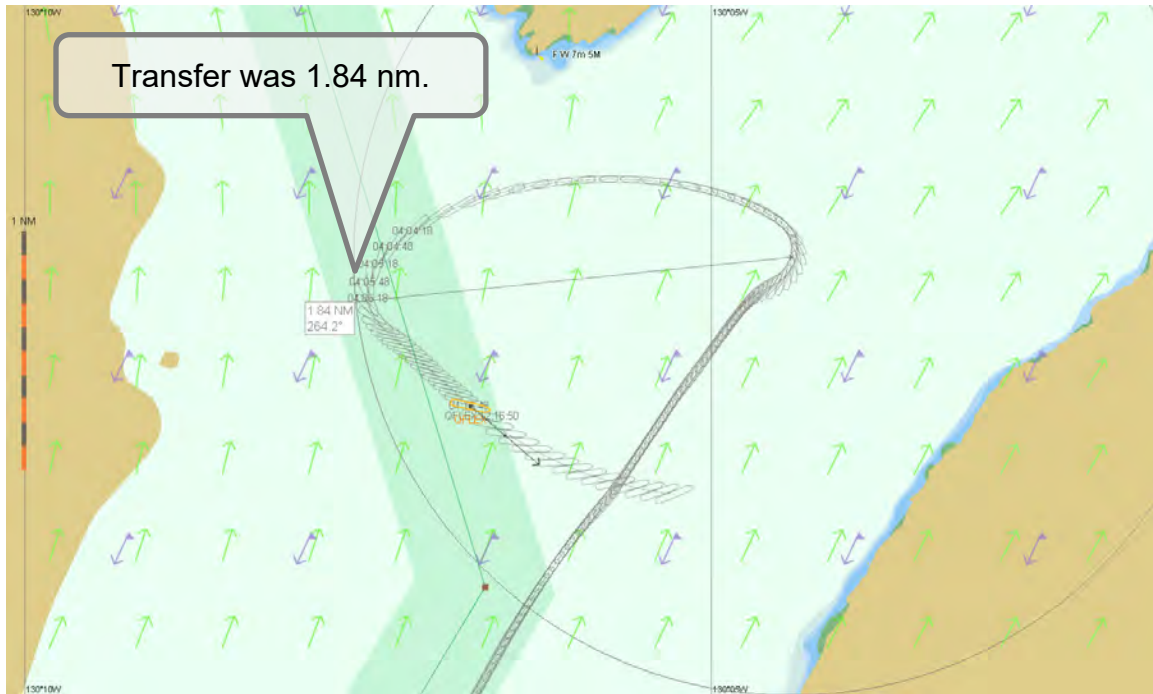
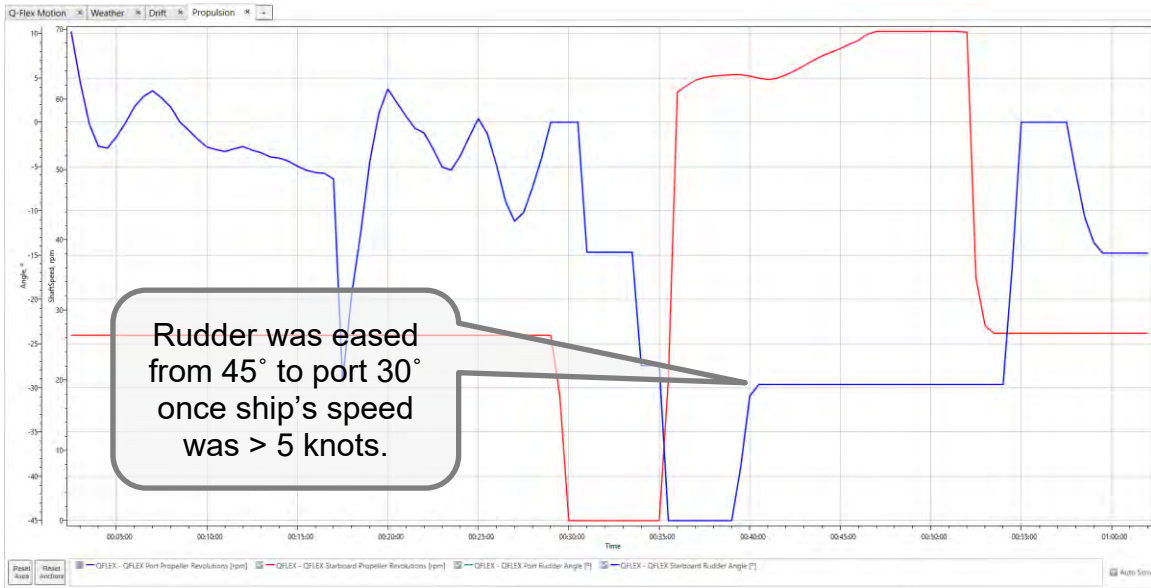

Figure 73: Rate of turn – turning stern through 50 knot winds (R1-10)



Figure 74: Rudder and RPM – turning stern through 50 knot winds (R1-10)



In the next test scenario, rather than trying to turn through the wind, the ship was held into the wind until it started to fall off, it was then allowed to drift downwind, and was then turned back up into the wind. This pattern was repeated for a three-hour period where throughout, the ship's course over the ground remained close to mid-channel. Once again, it should be stressed, that the goal of this test was to examine the ability to manoeuvre the ship, even absent tug assistance. This technique is controlled and used effectively without tug assistance. In this location, a tug from the terminal should always be available to aid during high winds. See Figure 75 to Figure 80 below:

Figure 75: Track-plot – Hour 1, holding in 50 knot winds (R1-11)

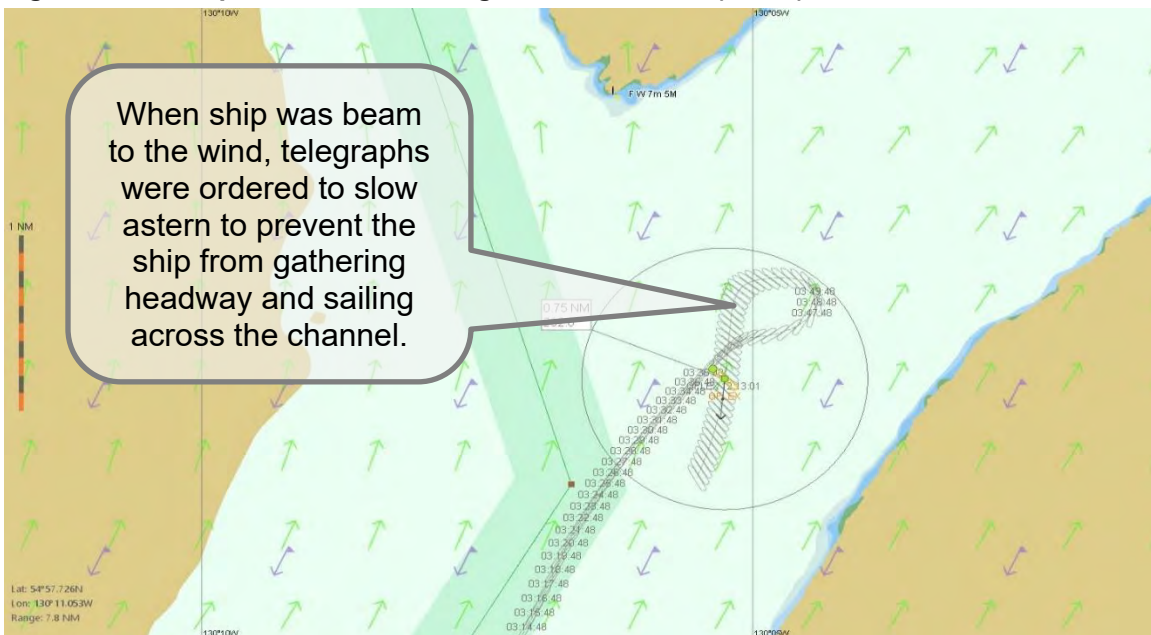

Figure 76: Rudder and RPM – Hour 1, holding in 50 knot winds (R1-11)

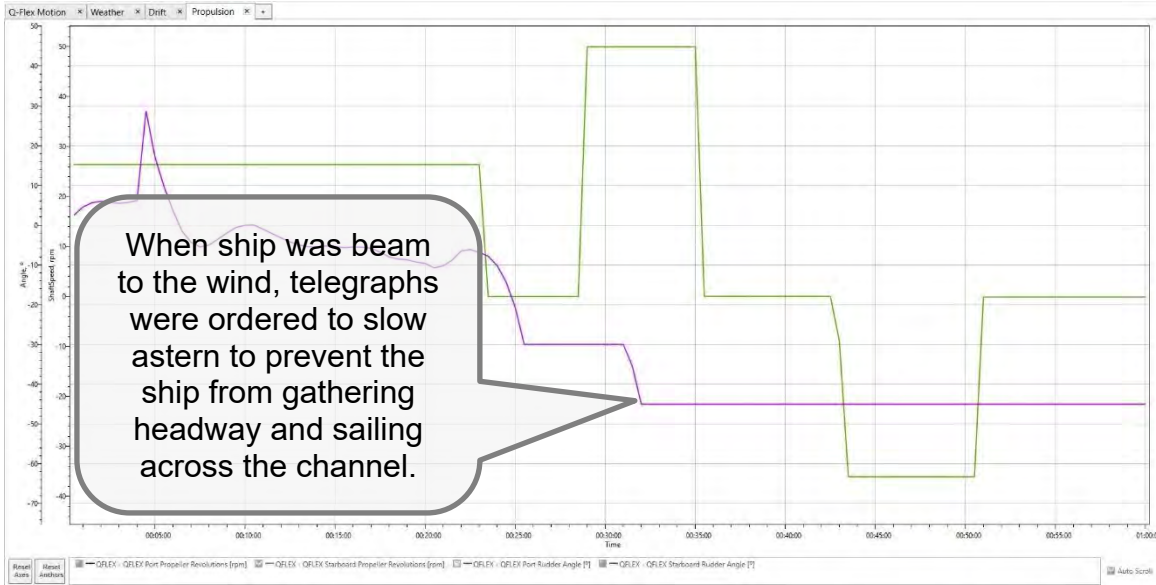

Figure 77: Track-plot – Hour 2, holding in 50 knot winds (R1-11)

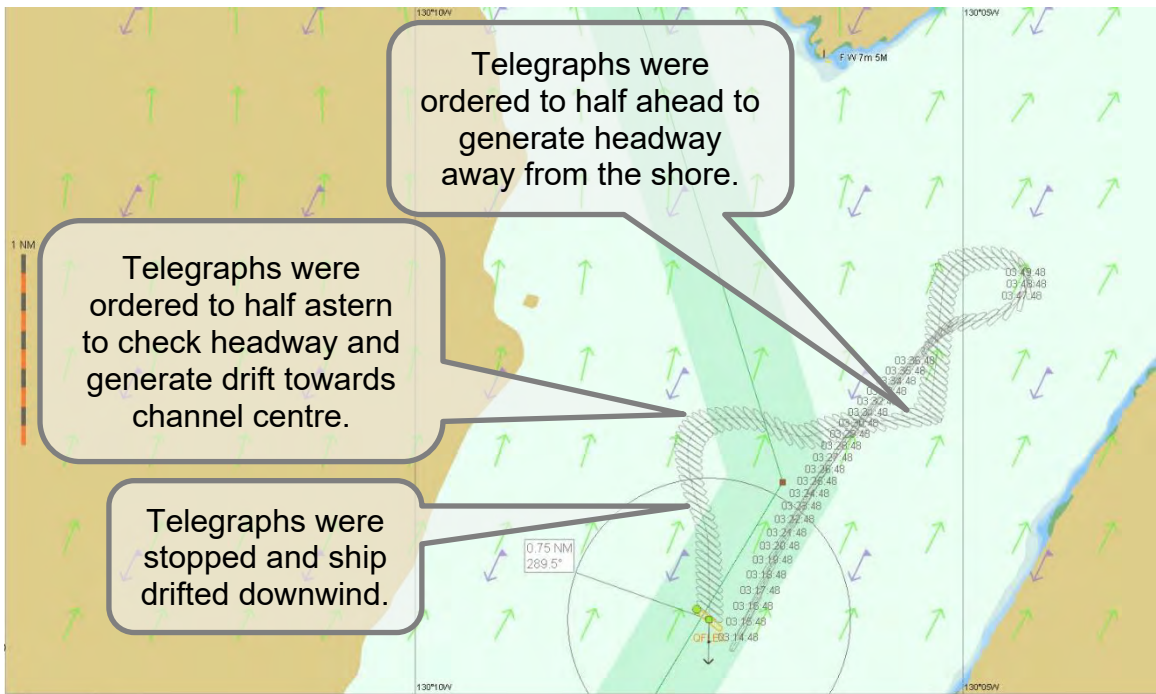

Figure 78: Rudder and RPM – Hour 2, holding in 50 knot winds (R1-11)

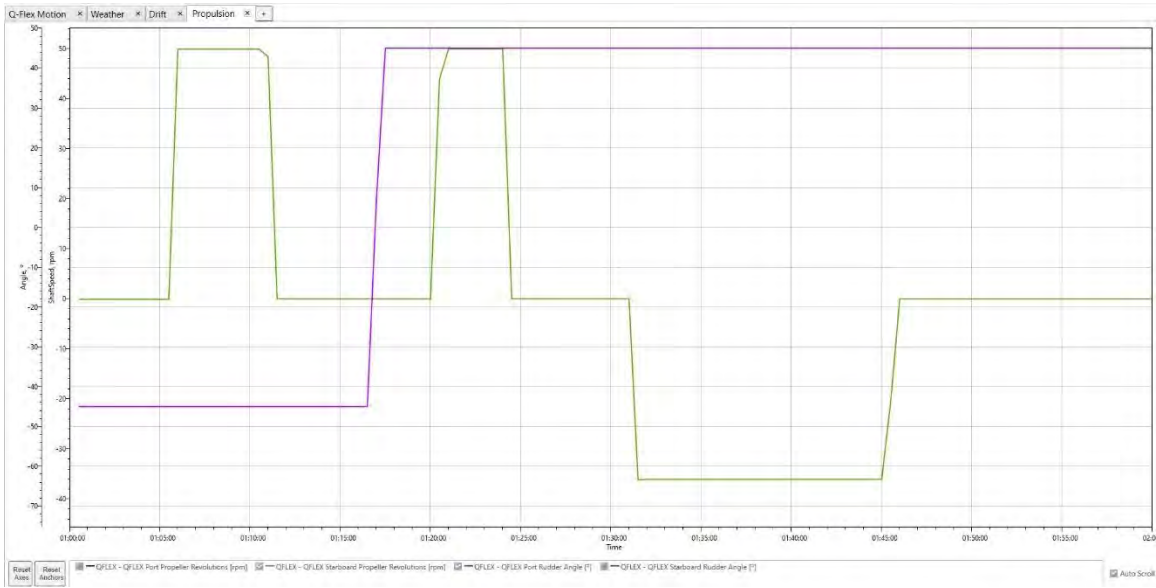

Figure 79: Track-plot – Hour 3, holding in 50 knot winds (R1-11)

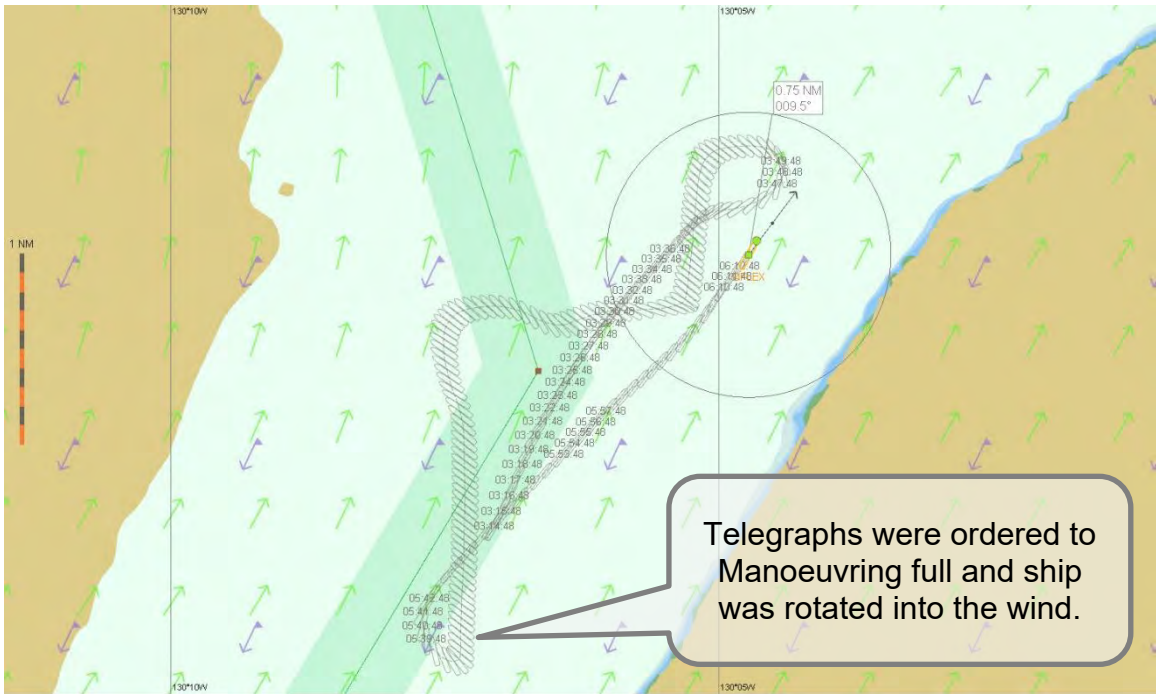
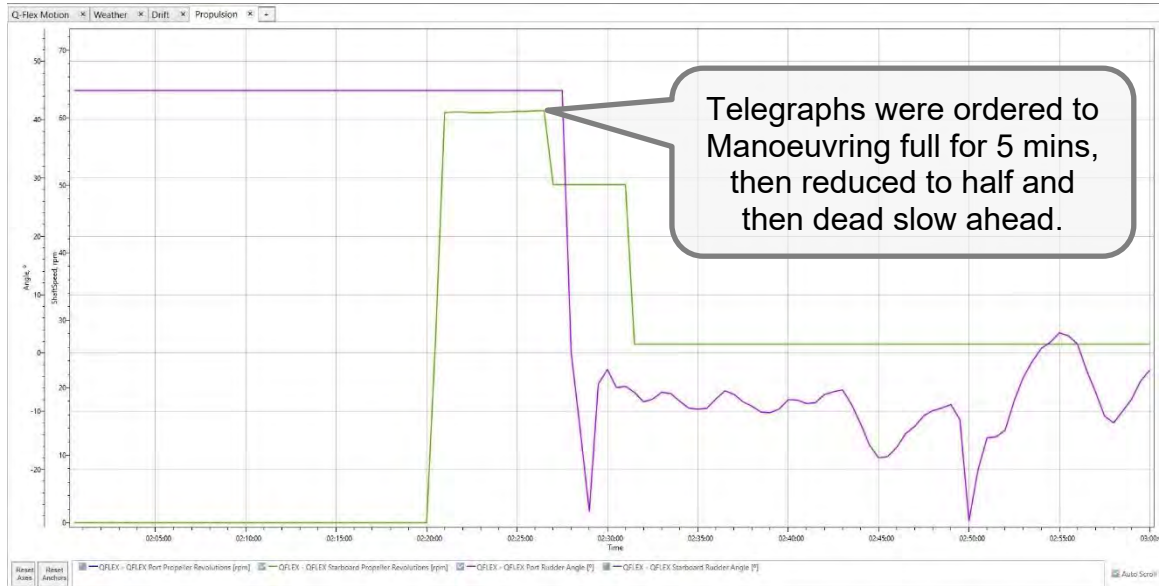

Figure 80: Rudder and RPM – Hour 3, holding in 50 knot winds (R1-11)



The next two scenarios included the employment of a tug to assist with rotating the ship. Within Portland Inlet is rare for the significant wave height to exceed 2.5 metres, hence it should always be possible for the tug to tether its line when needed.

For the first scenario, the ship was rotated using a technique often employed in more confined waters. As in the previous scenario, the ship was slowed to minimal steerage speed, and then the bow of the ship was allowed to fall off of the wind to port. Simultaneously, the tug was employed in direct pull mode to lift the stern of the ship into the wind. Initially, the bow fell off the wind rapidly, and the stern was even lifted into the wind, however as the ship rotated beam to the wind, the turn rate started to subside. See Figure 81 and Figure 82 below:

Figure 81: Tug assisted track-plot – initial rotation, falling off 50 knot winds (R1-12)

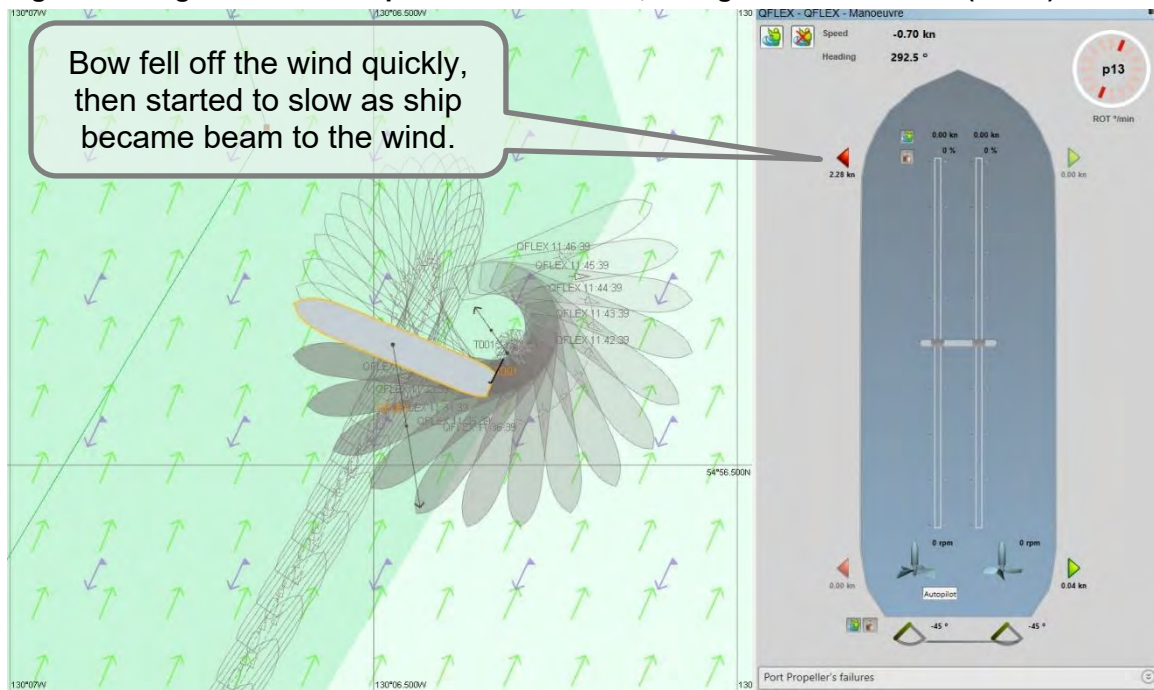
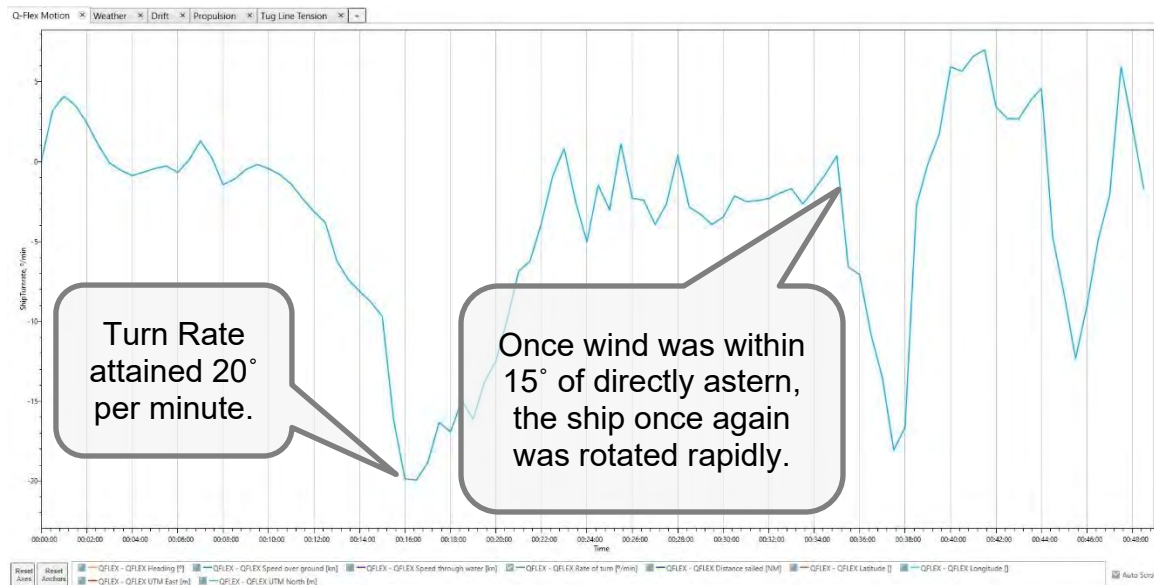
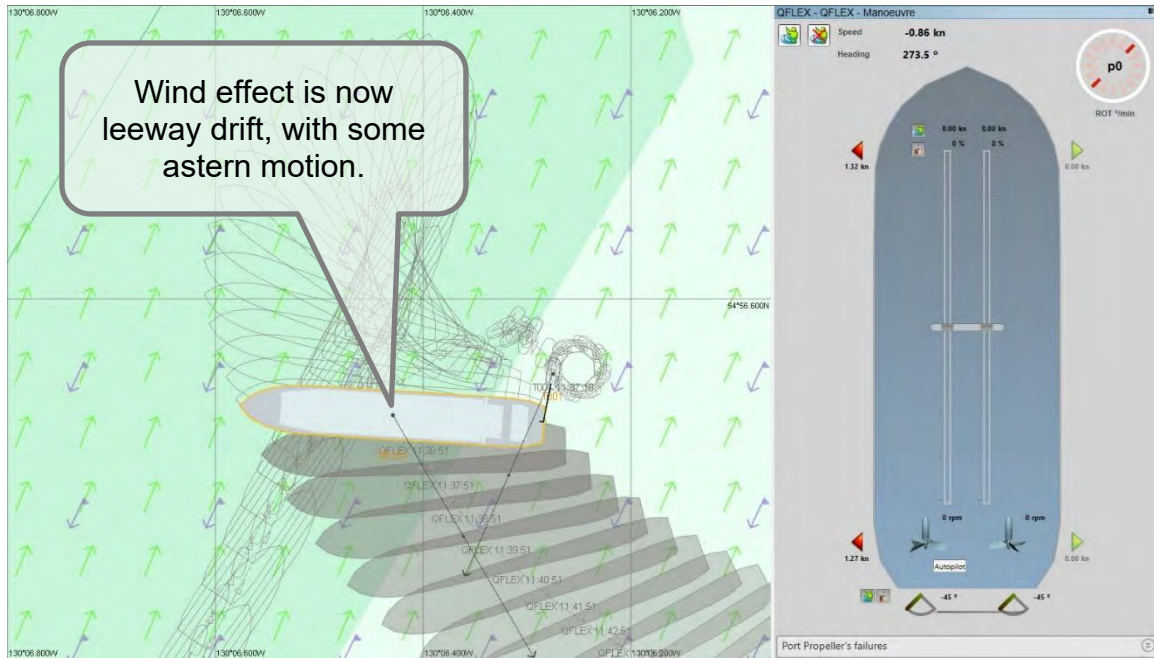

Figure 82: Rate of turn – falling off 50 knot winds (R1-12)



As the ship rotated with the wind on the beam, the effects of the wind started to manifest themselves as leeway drift as opposed to predominately rotational forces. Even with the tug pulling continuously at full power, the ship once again became “caught in irons” with the bow and stern drifting downwind with little rotation. The forces of the tug did however prevent the ship from gathering headway. See Figure 49 below:

Figure 83: Tug assisted track-plot – “in irons”, falling off 50 knot winds (R1-12)



At this point to continue rotating the ship, the telegraphs were ordered to Half Ahead, with the rudder hard over (See Figure 84). It was noted that if the engines were simply “kicked ahead” that the turn rate would subside as soon as the propeller RPMs were reduced. To complete the turn, once the ship’s heading was diagonal to the axis of the channel the telegraphs were left the Half Ahead position.

Figure 84: Tug assisted track-plot – kick ahead, falling off 50 knot winds (R1-12)

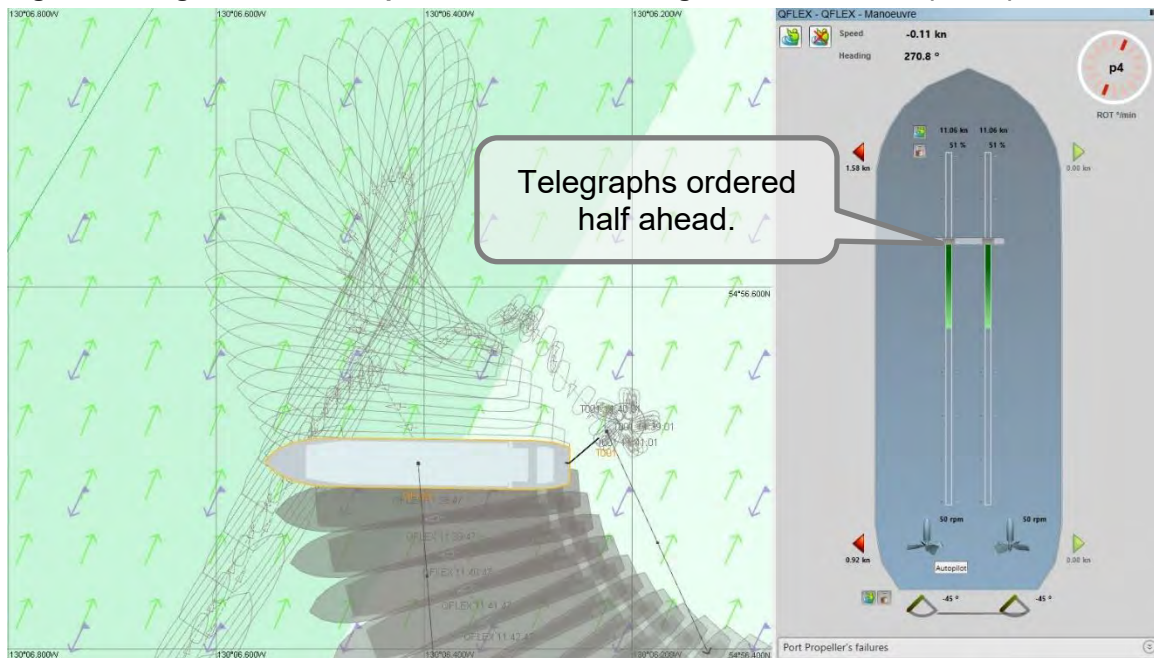

As the 217,000 m³ LNG carrier gathered headway, the tug in the direct pull position became less effective, so it was then employed in the powered indirect mode, and the telegraphs were ordered to Manoeuvring Full to complete the turn. The ship was then steadied on the starboard side of the track corridor such that it could be steered down the channel, and when desired, rotated tightly to port bringing the bow back into the wind / to loop around in the channel. See Figures 85 and 86 below:

Figure 85: Tug assisted track-plot – final rotation, falling off 50 knot winds (R1-12)

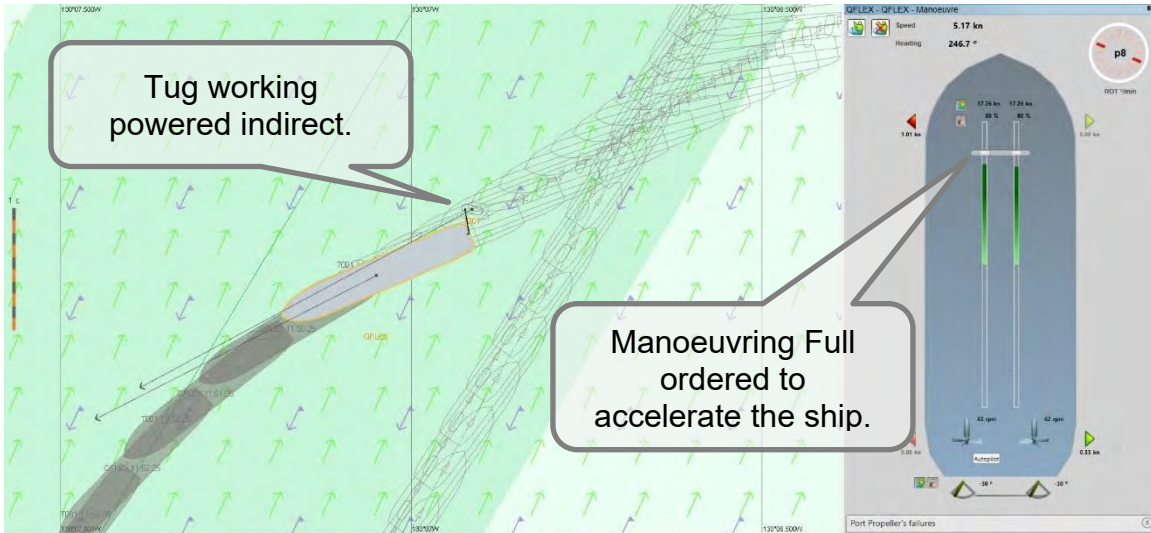
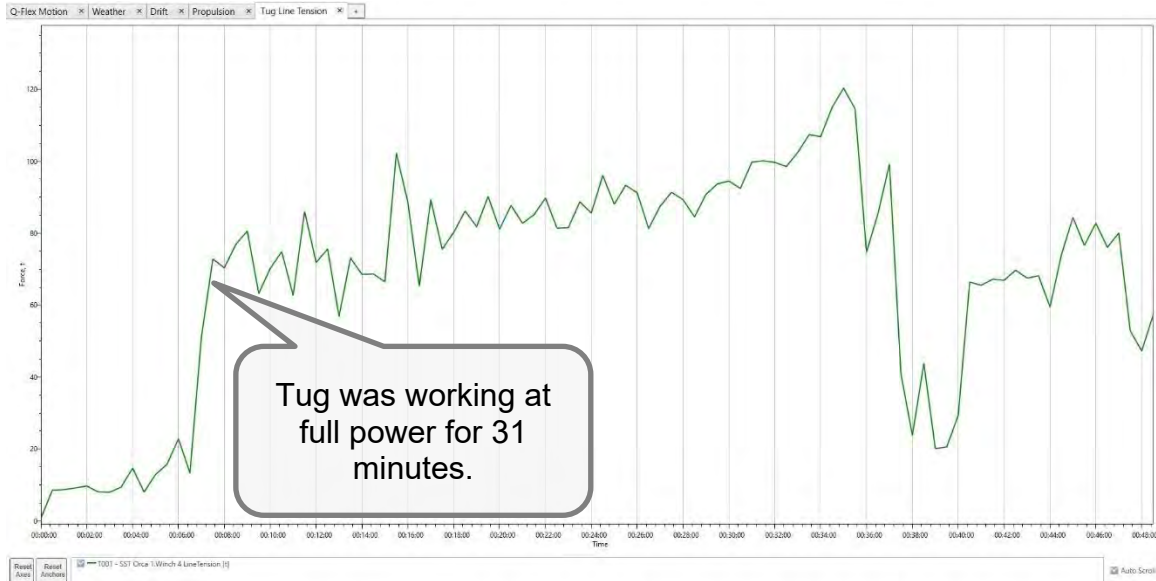

Figure 86: Tug assisted track-plot – falling off 50 knot winds (R1-12)



This method of turning was controlled, and at no time was the LNG carrier accelerating directly towards the shoreline. It did however require the tug to work at full power for a period that exceeded 30 minutes. See tug line force in Figure 87 below:

Figure 87: Tug line force – falling off 50 knot winds (R1-12)



For the second scenario, given that Portland Inlet is over two nautical miles in width, it was decided to rotate the 217,000 m³ LNG carrier in high winds, with tethered tug assistance at high speed. In this case, as the ship approached the desired turning point, the telegraphs were ordered to the Half Ahead setting. When the speed was above 8 knots, the rudder was ordered to port 30° and the telegraphs ordered to Manoeuvring Full. Simultaneously the tug was employed in the powered indirect position to accelerate the rudder induced turning moment. In contrast to the other manoeuvres, with this technique the stern of the ship during the initial portion of the turn is being lifted upwind rapidly and the turn rate peaked at 40°/ minute. The upwind momentum of the 217,000 m³ LNG carrier's stern allowed the ship to continue to turn without stalling, and even when the wind was on the quarter, the turn rate to port did not fall below 13° per minute. This technique allows the hull design of the tug to be used to its maximum efficiency and to generate towline (rotational forces) that are higher than its static bollard pull rating. See Figure 88 to Figure 91 below.

Figure 88: Tug assisted track-plot – initiating high speed turn, 50 knot winds (R1-13)



Figure 89: Tug assisted track-plot – high speed turn, 50 knot winds on quarter (R1-13)

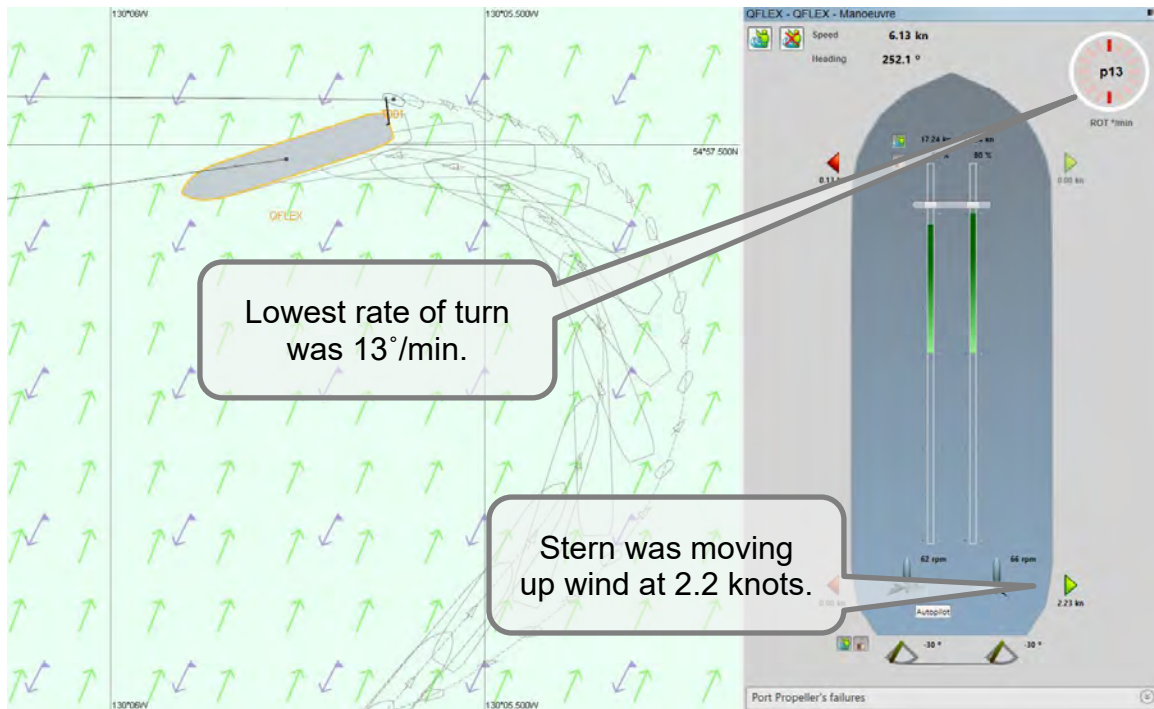

Figure 90: Rate of turn – high speed turn, 50 knot winds (R1-13)

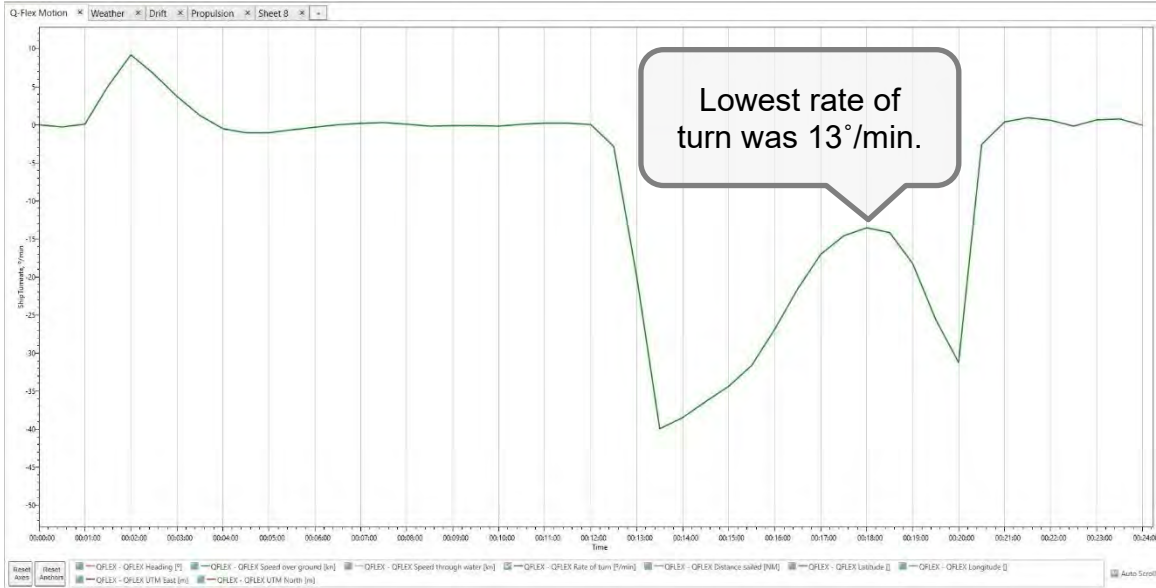
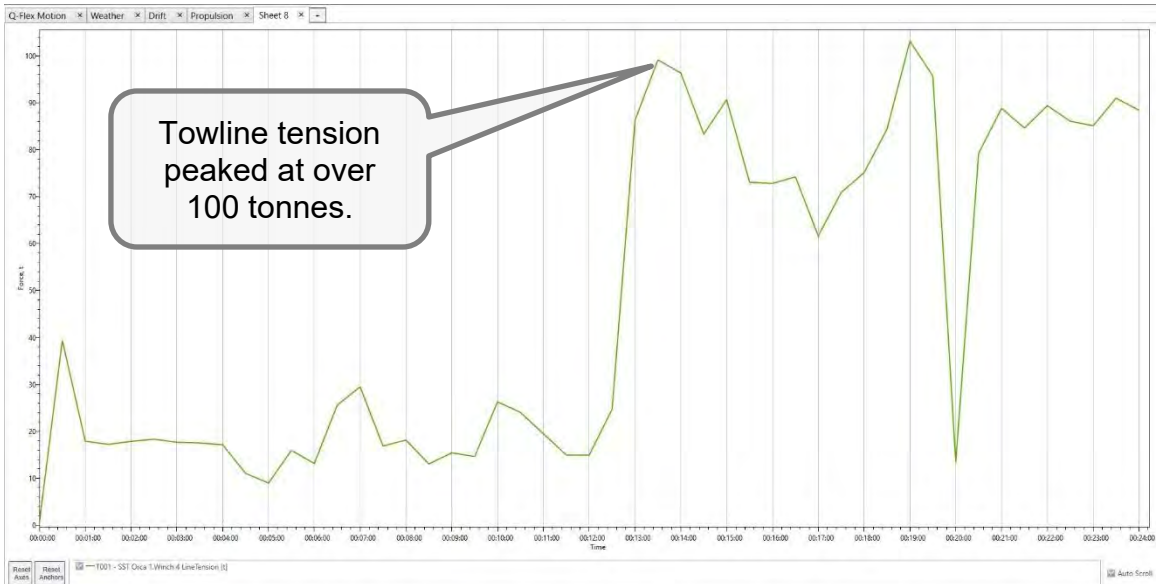

Figure 91: Tug line force – high speed turn, 50 knot winds (R1-13)



Overall, this manoeuvre was effective, and the ship was rotated 180° with a transfer of less than one-half nautical mile or approximately 900 metres. It took only nine minutes to complete the manoeuvre. It can be considered that it is possible to conduct a manoeuvre like this nearly anywhere in the central and northern route segments, provided that a tug is first tethered. See Figure 92.

Figure 92: Tug assisted track-plot – high speed turn, 50 knot winds (R1-13)



4.4 Observations on Aids to Navigation

As discussed in previous sections of this report, the area of highest navigational risk for the marine route is within the western route segment. The shoals in this area near Triple Island, and Hanmer Rocks are well indicated, both during the day and at night.

For most of the transit in the central route segment, the channel is deep to the shoreline, and there are few off-lying shoals. Pointer Rocks, and the islands to East of Dundas Island all have lights and markers including Connis Rocks.

The only shallow that is not marked is Moore Shoal which lies to the west of the buoy at Hodgson Reefs. This 13.4 metre shallow could, at extreme low tide, present a grounding risk to a LNGC with a draught of 12.0 metres or more. During normal transit procedures, this shoal is over 0.7 nautical miles (1,300 metres) from the track corridor, however if a loaded LNG carrier was holding position in this area Moore Shoal could be a hazard. Moore Shoal is a pinnacle, and it may not be easy to mark it with a buoy (i.e., an isolated danger buoy). Alternatively, a virtual aid to navigation could be considered. This can be reviewed by the CCG as part of ongoing LOS reviews.

The northern route segment is void of off-lying shoals, and the steep mountain slopes and foreshore lend themselves to very accurate radar navigation.

5 Conclusions and Recommendations

5.1 Conclusions

The Study provides an initial assessment of the overall navigational safety of the selected marine route to and from the marine terminal. This included identifying navigational risk and factors, variables, or elements that create or contribute to real navigation risk (versus potentially perceived risk) for LNG carriers up to 217,000 m³ capacity, and to assess the feasibility of the marine route to be used regularly over the life cycle of the Project. As one of the first steps leading to a formalized BCCP / PPA NRA process, this report does not identify detailed operating procedures for manoeuvres near the terminal or establish tug requirements. These policies will be determined as part of the combined PPA / BCCP NRA process. The simulation analysis has determined that the marine route is feasible for the regular movements of LNG carriers up to 217,000 m³ capacity with risk mitigation measures.

5.2 Environmental Limitations

Consistent with real-world operations and practises, and the handling characteristics of LNG carriers this analysis has demonstrated that under day-to day operating conditions, without tug assistance, the steering and positional control of vessels ranging in size from 145,000 m³ (285 metres LOA) to 217,000 m³ (315 metres LOA) is good up to a sustained wind speed of 30 knots with a transit speed of 10 knots or less.

Simulations show that a minimum transit speed of 10kts still provides a good level of steering control in wind speeds up to 30 knots from the stern quadrant, and up to 40 knots with winds from the bow quadrant. Slightly faster transit shows increased steering responsiveness and vessel control, but it is noted that faster speeds would become more challenging for escort tugs, if required.

For greater wind speeds, steering and positional control begins to reduce. However, simulations show that the marine route can be safely transited, without tug assistance, with wind speeds of up to 40kts in open water and 50kts in the fjords, albeit with more deviation from the course and with more exaggerated steering inputs required.

When wind speeds exceed 30 to 40 knots, pilot boarding conditions become difficult. Worldwide very few LNG terminals permit docking or undocking operations when the sustained wind speed exceeds 25 to 30 knots. Delays will be managed through the timing of departure from the marine terminal, arrival at the pilot boarding station, or modifying transit speed.

For planning purposes, it is recommended that:

- Transits are not planned when sustained winds of 40 to 50 knots or more are forecasted during the approximately 6-hour transit window;
- Given that most of the transit the channel is deep and exceeds 1.5 nautical miles in width, and that the most constrained area (the buoys at Hanmer Rocks) is over 1,000 metres wide, it is recommended that transits be performed at any time of the day, and during any state of tide. This would be consistent with existing policy in place for LPG

ships, and bulk and container ships, many of which are much bigger and more deeply laden than a 217,000 m³ LNG carrier; and

- Given the width of the channel, and the relatively low volume of vessel traffic, there is ample room for vessel passing / meeting. One potential exception (during adverse weather conditions) is the area between 1 nautical mile east of Hammer Rocks to Triple Island when a loaded vessel is outbound. This should be tested during the FMBS.

5.3 Tug Requirements

Berthing tugs will be available for all movements to and from the facility and specific details of these requirements will be assessed during the FMBS.

Tug requirements should be tested more thoroughly during the FMBS and the combined PPA / BCCP NRA process. Any Project policy must also be consistent with the evolving PPA escort tug requirements for the North Coast.

If transits need to be conducted with sustained winds greater than 30 to 40 knots, consideration should be given to tethering an escort tug to enhance steering control, particularly for any track legs where the wind will be from the astern quadrant.

5.4 Aids to Navigation

Consideration should be given to installing an aid to navigation on Moore Shoal. If physically feasible this would be an isolated buoy or alternatively a virtual aid to navigation. This can be reviewed by the CCG as part of ongoing LOS reviews.

5.5 Recommendations

This assessment has confirmed the feasibility of the marine route during operational conditions. In collaboration with the relevant stakeholders, including PPA and BCCP, further navigation simulation is recommended as the Project develops to:

- Identify and assess emergency response situations to develop suitable mitigation measures,
- Confirm tug requirements, and
- Establish and confirm berthing and unberthing procedures at the marine terminal.

Additional desktop simulation may efficiently assess some aspects listed above, before the FMBS.

Appendix A: Existing Procedural References



BC Coast Pilots / Pacific Pilotage Authority

Navigational Risk Assessment



11 Jan 2023

PURPOSE

The Navigational Risk Assessment (NRA) procedure is designed to ensure that all necessary steps have been taken to ensure safe navigation to/from a marine facility or through a waterway. It is intended to be scalable; to follow principles of openness and transparency; to use a scientific, evidence-based process to make rational decisions; and to adhere to the mandate of safety of navigation while protecting human health, property, and the environment during the efficient movement of ships. The NRA process has been co-developed between the British Columbia Coast Pilots (BCCP) and the Pacific Pilotage Authority (PPA).

An NRA will apply within the compulsory pilotage waters as defined in the Pacific Pilotage Regulations, to any of the following PROJECTS:

- new terminals
- new passenger vessels operating on the West Coast (if subject to Pilotage)
- modifications to existing terminals
- marine terminals after being unused in the previous five years
- significant increase in vessel size operating in a given area
- significant change in vessel type / class operating in a given area
- significant change in berthing procedure
- identified safety deficiencies in a given area
- when a government agency has asked for pilotage input regarding a project
- other similar changes to existing operations

Participation in the NRA does not guarantee the approval of the proposed PROJECT from a safe navigation perspective.

PROCESS

The BCCP, the PPA, and the proponent(s) will collectively identify relevant authorities and stakeholders who will be involved or affected throughout the assessment process. These will collectively form the NRA's Risk Assessment Committee (RAC).

The RAC will determine the scope of the risk assessment and if the PROJECT will require a tabletop exercise, fast time / desktop simulation, real time bridge simulation, live trials, pilot training, or some combination thereof. The RAC will also determine the requirements for each of these steps, with the costs to be solely the responsibility of the proponent. Note that a consultant may be contracted by the proponent to complete one or more of these steps, provided the consultant is mutually agreed upon by the RAC.

The RAC will establish a critical path with timelines allowing for possible revised assessment through consultation with any affected parties. A sample Critical Path is included below as Annex A. Minutes will be taken of each meeting. A project-specific log will be created for each assessment to record the dates of meetings, those present, the subjects discussed, and any discussions or decisions.

TABLETOP EXERCISE

A tabletop exercise involves key personnel discussing simulated scenarios related to the PROJECT in an informal setting. They can be used to broadly assess plans, policies, and procedures with minimal investment, and may be very useful to help develop guidelines and criteria for simulations.

If the RAC determines that a tabletop exercise is required, then the RAC will ensure the below are conducted.

- Determine tabletop objectives and participants
- Confirm requirements needed to meet those objectives. These may include, among others:
 - Navigation Charts for a terminal / loading area / approaches / waterway
 - Bathymetry plans for a terminal / loading area / approaches / waterway
 - Environmental data (weather/tide/current/visibility) for the area
 - Plans for any proposed facility
 - Design ship or tug particulars
- Document results of the tabletop exercise and generate a detailed report
- Send the Report to Pilots (BCCP/FRP) for input / recommendations
- Use the Pilots' recommendations and Report to guide the remainder of the NRA process

Note that costs for any of the above are solely the responsibility of the proponent.

SIMULATIONS

Simulations may be either fast-time desktop simulations, or real-time bridge simulations. With a desktop simulation, all aspects of the simulation and ship control mechanisms are being controlled by one computer with a single user interface for the instructor / tester. This contrasts with the fully immersive real-time full mission bridge simulator, where a marine pilot with real controls and radio devices controls the ship and co-ordinates all tug activity, and tug captains using real control equipment manoeuvre each tug. Additionally, with desktop / fast-time simulation, all analysis is based on assessment of numerical outputs and data plots, and a given scenario may be able to be attempted hundreds of times at very high speeds – but a limiting factor with fast-time simulations is they do not allow for human expertise and experience, and can only factor in the variables programmed beforehand. In contrast, full mission simulation adds the total immersion environment which incorporates human factors, man-machine interface and the assessment (sometimes subjective) of operational feasibility and risk analysis as if the operation were being conducted in real life and at real-world speeds. Note that simulation is a valuable research tool for assessing navigational risk, but may not be sufficient when used in isolation to determine the feasibility of a proposed PROJECT.

If the RAC determines that simulations – either fast-time or full mission bridge – are required, then the RAC will ensure the below are conducted:

- Determine objectives and participants of the simulation(s). It is possible only a sub-committee of the full RAC may be required to participate, or Subject Matter Experts may be required.
- Review and agreement of proposed simulation scenarios. Note that scenarios must retain a margin of safety, as well as be realistic for the geography.
- Confirm requirements needed to achieve a realistic simulation. These may include, among others:
 - Navigation Charts for terminals / loading areas / approaches / waterways
 - Bathymetry plans for terminals / loading areas / approaches / waterways
 - Environmental data (weather/tide/current/visibility) for the area

- Plans for any proposed facility
- Design ship or tug particulars
- Geographical database model for the area (Level of Detail to be determined by the RAC).
- 3-D multilayer tidal current model for the area.
- Design ship model(s) (pilot-grade) based on the dimensions, characteristics, and handling capabilities of the proposed vessel.
- Tug model(s) (pilot grade) based on the dimensions, characteristics, and handling capabilities of the proposed tugs.
- Validation of the above models (geography, current, ships, tugs) prior to commencement of the simulation, either empirically or by comparison to Pilots' expert knowledge.
- Agreement with PSTAR for consulting services.
- Sub-contracting of a facilitator to run the simulations.
- Recognition of the potential requirement for development of a pilot training program to allow for safe navigation.
- Agreement that any geographical database, current models, or ship/tug models will be retained by PSTAR for future pilot training needs.

Note that costs for any of the above, including a pilot training program if required, are solely the responsibility of the proponent.

Following the simulations:

- Results will be documented and reviewed by simulation participants.
- A simulation report will be generated by the facilitator based on the results and findings.
- Initial recommendations will be developed by the RAC based on the report.
- Report and initial recommendations will be provided to Pilots (BCCP or FRP) for input.
- Report, initial recommendations, and Pilots' input provided to the RAC for their consideration.

LIVE TRIALS

Preliminary live trials are intended to be conducted in a manner that will have control measures implemented to manage risk. Once initial/first step trials are completed the risk will be re-analyzed before developing trials for any next step. Unacceptable risks that cannot be mitigated through control measures at any step along the way will take the PROJECT back to the tabletop / simulation stage for re-evaluation.

If the RAC determines that live trials are required, then the RAC will ensure the below are conducted:

- Determine objectives and participants of the live trial(s)
- Consultation with pilots (BCCP/FRP)
- Agreement on number of Live Trials
- Control measures and mitigations clearly defined

The following will be taken into consideration before and during each Live Trial:

- Age and condition of the vessel
- Communications with bridge crew
- Conditions of the shipboard electronics
- Trim of vessel (mean draft)
- Tide and current
- Visibility

- Particulars of the proposed transit (berthing, unberthing)
- Appropriate emergency preparations (anchors on stand by, lookouts, etc.)
- Vessel handling characteristics / speed considerations
- Tugs
- Pilot's onsite assessment and agreement to participate

Following the Live Trials

- Pilots submit reports following each Live Trial identifying any safety concerns or suggestions for improvements
- Reports provided to pilots (BCCP / FRP) for input
- Reports and pilots' input provided to the RAC for their consideration

REVIEW

The RAC will take into consideration the findings from any tabletop exercise, fast time simulation, real time simulation, live trials, and input from the Pilots to determine if the proposed PROJECT can be safely adopted from a piloting perspective.

A risk matrix may be employed to evaluate and estimate the probability and severity of adverse consequences. The RAC may identify risk mitigations that are required to reduce the probability and/or severity to acceptable levels before the proposed PROJECT is implemented.

RISK MITIGATIONS

Risk mitigation measures may be required and could include, amongst others:

- New/improved navigational aids
- Tugs
- Tide/current restrictions
- Visibility restrictions
- Day / Night restrictions
- Pilot training program
- Pilot restrictions (class, number required, experience)
- Tug master training program
- Real time information / sensors
- Improvements to berth / fenders
- Dredging / Channel enhancements

Note that costs for any of the above mitigations are solely the responsibility of the proponent.

RECOMMENDATIONS

The RAC will generate a report containing their recommendations and any required risk mitigations for the proposed PROJECT and submit to the proponent, PPA, BCCP/FRP, and any relevant authorities or stakeholders for review. The final report from the RAC will take into consideration any comments received and be disseminated to all affected parties.

All required risk mitigations must be in place before proceeding with the PROJECT.

ACKNOWLEDGEMENT

Acknowledgement of the above by the proponent in writing is required before proceeding with the Navigational Risk Assessment.

NO GUARANTEE OF APPROVAL

Participation in the Navigational Risk Assessment does not guarantee approval for the proposed PROJECT.

JOINT DOCUMENT

These protocols were co-developed by both the PPA and the BCCP, and should not be updated without concurrence between both parties.

- BCCP document QAS-4501
- PPA document PPAGC-13-904



BC Coast Pilots / Pacific Pilotage Authority

NRA – Annex A – Critical Path Template



PROJECT NAME - Navigation Risk Assessment Scope and Critical Path / Timeline

Background:

PROPONENT has proposed a PROJECT which is subject to a Navigational Risk Assessment process following the NRA guidelines.

Scope:

In order to assess the viability and safety of the PROJECT, multiple stages of tabletop exercises, simulations, and/or live trials may need to be conducted to test the basics of the design itself, as well as to determine safe berthing practices and environmental limitations. The outcome of these exercises, simulations, and trials – as well as any risks and mitigations identified - will be used to inform the Risk Assessment Committee (RAC) and assist them with developing a Final Report. Note that the RAC will determine which of the above are required – not necessarily all of them are appropriate for every PROJECT, and there could be multiple simulations required.

Critical Path:

The expected Critical Path and timeline, as prescribed by the NRA process, is as follows:

Description of Event or Process	Responsible Party	Timeline	Status
1. Determine RAC members	BCCP, PPA, & Proponent		
2. Confirm NRA Scope and Critical Path.	RAC		
3. Conduct Tabletop exercise <ul style="list-style-type: none"> <input type="checkbox"/> Determine objectives and participants <input type="checkbox"/> Confirm requirements: <ul style="list-style-type: none"> <input type="checkbox"/> Nav Charts <input type="checkbox"/> Bathymetry plans <input type="checkbox"/> Environmental data <input type="checkbox"/> Plans for any proposed facility <input type="checkbox"/> Design ship or tug particulars <input type="checkbox"/> Document results <input type="checkbox"/> Generate detailed report <input type="checkbox"/> Share report with Pilots 	RAC		
4. Conduct Simulations <ul style="list-style-type: none"> <input type="checkbox"/> Determine objectives and participants <input type="checkbox"/> Agreement of simulation scenarios <input type="checkbox"/> Confirm requirements: 	PSTAR		



BC Coast Pilots / Pacific Pilotage Authority

NRA – Annex A – Critical Path Template



<ul style="list-style-type: none"> <input type="checkbox"/> Navigation Charts <input type="checkbox"/> Bathymetry plans <input type="checkbox"/> Environmental data <input type="checkbox"/> Plans for any proposed facility <input type="checkbox"/> Design ship or tug particulars <input type="checkbox"/> Geographical database model <input type="checkbox"/> 3-D multilayer tidal current model <input type="checkbox"/> Design ship model(s) <input type="checkbox"/> Tug model(s) <input type="checkbox"/> Validation of the above models <input type="checkbox"/> Agreement for consulting services. <input type="checkbox"/> Development of a training program? <input type="checkbox"/> Agreement that models will be retained by PSTAR <input type="checkbox"/> Conduct Simulation <input type="checkbox"/> Document and review results <input type="checkbox"/> Generate simulation report <input type="checkbox"/> Develop initial recommendations <input type="checkbox"/> Share with Pilots for input 			
<p>5. Review Simulation reports</p> <ul style="list-style-type: none"> <input type="checkbox"/> Use Risk Matrix if required to ID mitigations, and make recommendations to Proponent 	RAC		
<p>6. Incorporate results of Simulations into final PROJECT designs</p>	Proponent		
<p>7. Conduct Live Trials</p> <ul style="list-style-type: none"> <input type="checkbox"/> Determine number of trials, objectives, and risk management <input type="checkbox"/> Determine appropriate vessels <input type="checkbox"/> Determine appropriate environmental conditions (tide, current, visibility, wind, etc.) <input type="checkbox"/> Determine safety considerations (tugs, anchors, speed, angle, etc.) <input type="checkbox"/> Participating pilots record assessments <input type="checkbox"/> Provide reports and Recommendations to RAC 	Pilots / Proponent		
<p>8. Review Live Trails and use Risk Matrix if required to ID mitigations.</p>	RAC		
<p>9. Generate Final Report, containing all recommendations and mitigations.</p>	RAC		



BC Coast Pilots / Pacific Pilotage Authority

NRA – Annex A – Critical Path Template



10. Formulate a training plan and schedule for all pilots based on the RAC's Final Report.	PTEC		
11. Implement the training schedule prior to changes in operations	PTEC		

Appendix B

Existing Lights, Buoys and Fog Signals



B Existing Lights, Buoys and Fog Signals

Table B- 1 – List of existing lights, buoys and fog signals [36]

No.	Name	Position ----- Latitude N. Longitude W.	Light Characteristics	Focal Height in metres above water	Nominal Range	Description ----- Height in metres above ground	Remarks ----- Fog Signals	Chart
Dixon Entrance								
807.1	Dixon Entrance West ODAS light buoy 46205	54 11 06 134 19 24	Fl (5) Y 20s	-	-	Yellow, marked "46205".	Year round.	3000 Edn 10/15 (P15- 077)
807 G5856	Langara Point	On NW. point of Langara Island 54 15 21.9 133 03 35.8	Fl W 5s	48.8	8	White octagonal tower.	Flash 1s, eclipse 4s. Emergency light. Year round.	3868
804.6 G5851	Shag Rock	NW. of Cape Naden. 54 09 25.3 132 39 02.7	Fl (3) W 12s	7.2	5	Mast.	Flash 0.5 s; eclipse 2 s; flash 0.5 s; eclipse 2 s; flash 0.5 s; eclipse 6.5 s. Year round.	3892
801	Central Dixon Entrance ODAS light buoy 46145	NNW. of Wiah Point. 54 22 00 132 26 37.8	Fl (5) Y 20s	-	-	Yellow, marked "46145".	Year round.	3800 Edn 10/12 (P12- 044) Edn 10/15 (P15- 074)
798.8	Wiah Point light and bell buoy C50	N. of point. 54 07 22.4 132 18 39	Fl R 4s	-	-	Red, marked "C50".	Year round.	3892

No.	Name	Position ----- Latitude N. Longitude W.	Light Characteristics	Focal Height in metres above water	Nominal Range	Description ----- Height in metres above ground	Remarks ----- Fog Signals	Chart
791	Rose Point light and bell buoy C26	N. of point. 54 12 59 131 39 11.9	Fl R 4s	-	-	Red, marked "C26".	Year round.	3800 Edn 10/12 (P12- 043)
790	Rose Spit East Cardinal light and whistle buoy CUT	NE. of Overfall Shoal. 54 14 52.9 131 30 48.0	Q(3) W 10s	-	-	Black, yellow and black, marked "CUT".	Year round.	3800 Edn 10/12 (P12- 042) Edn 11/17 (P17- 061)
Brown Passage								
751.1	Stenhouse Shoal light and whistle buoy D59 racon - . - . (C) X & S Bands	S. of shoal, W. entrance to Brown Passage. 54 20 07 130 56 03	Fl G 4s	-	-	Green, marked "D59".	Year round.	3957
751.2	Brown Passage light and whistle buoy D60	NW. of Triple Island, W. entrance to passage 54 18 23.8 130 54 51.7	Fl R 4s	-	-	Red, marked "D60".	Year round.	3957
752 G5812	Triple Islands	On the northwesterly rock of the islands. 54 17 40.7 130 52 49.8	Fl (2) W 9s	28.2	16	White octagonal tower.	Flash 0.25 s; eclipse 2.5 s; flash 0.25 s; eclipse 6 s. Year round.	3957
752.2 G5811.5	Osborne Island	54 17 11.8 130 51 11.2	Fl R 6s	10.2	5	White cylindrical tower.	Flash 0.5 s; eclipse 5.5 s. Year round.	3957

No.	Name	Position ----- Latitude N. Longitude W.	Light Characteristics	Focal Height in metres above water	Nominal Range	Description ----- Height in metres above ground	Remarks ----- Fog Signals	Chart
752.3 G5812.3	Hanmer Rocks racon - - (M) X & S Bands	54 19 26.5 130 49 20.3	Fl (3) W 12s	10.9	7	White octagonal tower.	Flash 0.5 s; eclipse 2 s flash 0.5 s; eclipse 2 s; flash 0.5 s; eclipse 6.5 s Year round.	3957
753	Hanmer Rocks light and whistle buoy D57	54 18 54 130 48 56.3	Fl G 4s	-	-	Green, marked "D57".	Year round.	3957
753.1	Hanmer Rocks light and whistle buoy D62	54 18 21.2 130 48 32.2	Q R 1s	-	-	Red, marked "D62".	Year round.	3957
719 G5807	Lucy Islands	On NE. side of E. island. 54 17 44.6 130 36 31.6	Fl R 6s	21.6	14	White octagonal tower.	Flash 0.5 s; eclipse 5.5 s. Year round.	3957
Chatham Sound								
724	Hodgson Reefs light and whistle buoy D84	W. of reefs. 54 23 02.5 130 32 34.8	Fl R 4s	-	-	Red, marked "D84".	Year round.	3957
726	Tree Bluff light and bell buoy D86	At end of shoal W. of bluff. 54 25 44.5 130 30 51.5	Fl R 4s	-	-	Red, marked "D86".	Year round.	3963
730.5 G5813	Whitesand Island	54 30 48.4 130 44 57.	Fl W 4s	6.7	5	White square skeleton tower.	Year round.	3959

No.	Name	Position ----- Latitude N. Longitude W.	Light Characteristics	Focal Height in metres above water	Nominal Range	Description ----- Height in metres above ground	Remarks ----- Fog Signals	Chart
730 G5814	Green Island	On SW. side of island. 54 34 07 130 42 31.5	Fl W 5s	19.2	17	White octagonal tower.	Flash every 5 s. Year round.	3959
729.5	Connis Rocks	54 34 27.9 130 37 39.0	Fl (2) W 5s	9.2	5	White square skeleton tower. 7.5	Radar reflector. Year round.	Chart:3959 Edn 04/19 (P19- 006)
729 G5822	Pointer Rock	On the southernmost rock. 54 36 17.7 130 32 14.9	Fl W 6s	7.8	5	White cylindrical tower.	Flash 0.5 s ; eclipse 5.5 s. Year round.	3959
731 G5816	Holliday Island	On N. extremity of island. 54 37 22.8 130 45 30.1	Fl W 6s	6.5	5	White square skeleton tower.	Flash 0.5 s ; eclipse 5.5 s. Year round.	3960
Portland Inlet and Portland Canal								
755 G5866	Ramsden Point	On extremity of point, Portland Inlet. 54 58 59.7 130 06 16.2	Fl (3) W 12s	7.1	5	Orange square skeleton tower.	Flash 0.5 s ; eclipse 2 s ; flash 0.5 s ; eclipse 2 s ; flash 0.5 s ; eclipse 6.5 s. Year round.	3920
756 G5882	Reef Island (U.S.)	S. end of island. 55 04 44.5 130 12 04.3	Fl W 4s	5.8	6	Mast, red and white diamond daymark.	Obscured from 020°30' to 197°30'. Year round.	3933

1 **ATTACHMENT E.3 CASUALTY DATA AND RISK ANALYSIS**

Ksi Lisims LNG
Navigation Safety Assessment

Casualty Data and Risk Analysis

11 October 2023



Disclaimer

This report is not intended to stand alone without reference to the instructions given to Westmar by Ksi Lisims LNG, communications between Westmar and Ksi Lisims LNG, and any other reports, proposals or documents prepared by Westmar for Ksi Lisims LNG under the governing contract between Westmar and Ksi Lisims LNG. To understand the suggestions, recommendations and opinions expressed herein, reference must be made to all relevant documents and communications.

This report has been prepared only for the purposes that are set out in the governing contract between Westmar and Ksi Lisims LNG. The findings, recommendations, suggestions and or opinions expressed in this report are only applicable to the purposes for which the report is expressly provided, and then only to the extent that there has been no material alteration to or variation from the information provided or available to Westmar.

The information and opinions expressed in this report are for the sole use and benefit of Ksi Lisims LNG. No other party may use or rely upon the report or any portion thereof without Westmar's prior written consent, and such use shall be on terms and conditions as Westmar expressly approves. Ownership in and copyright for the contents of the report belong to Westmar. Any use which a third party makes of the report is the sole risk and responsibility of such third party. Westmar accepts no responsibility whatsoever for loss or damages suffered by any third party in relation to use of this report.

Company Details

Westmar Advisors Inc.
700 – 1901 Rosser Avenue
Burnaby, BC V5C 6R6
T 604-770-4787
info@westmaradvisors.com

Table of Contents

Abbreviations	v
Preface	x
1 Introduction	1
1.1 Casualty Data	1
1.2 Risk Analysis	1
2 Project Background	2
2.1 Project Design Vessel Specifications	2
2.2 Preliminary Mitigation Measures	3
3 LNG Carrier Safety	5
3.1 International Cooperation	5
3.2 Canadian Initiatives	6
3.3 Regional Initiatives	7
4 Casualty Data Survey	8
4.1 Canadian Context	8
4.1.1 LNG Carriers.....	8
4.1.2 NGL Product Vessels	9
4.2 Global Casualty Data	9
4.2.1 Global Trends.....	9
4.2.2 LNG Carriers.....	9
4.2.3 NGL Product Vessels	10
4.3 Local Casualty Data	11
4.3.1 Transportation Safety Board of Canada	11
4.3.2 Pacific Pilotage Authority Incident Reporting.....	12
4.3.3 Clear Seas Centre for Responsible Marine Shipping.....	12
4.4 Terminal Incidents	14
4.5 Casualty Data Summary	14
5 General Risk Analysis	15
5.1 Introduction	15
5.2 Risk Analysis Methodology	15
5.2.1 Risk Analysis – Next Steps.....	16
5.3 Hazard Identification	17
5.3.1 Hazard Mitigation	18
5.4 Incident Frequencies	18
5.4.1 Conditional Probabilities	19
5.5 Consequence Assessment	20

5.5.1	Cargo and Fuel Properties	20
5.5.2	Condensate Properties.....	21
5.5.3	Fuel Properties.....	21
5.5.4	Release at the Marine Terminal	22
5.5.5	Collision and Terminal Allision.....	22
5.5.6	LNG Carrier Grounding	23
5.5.7	NGL Product Vessel Grounding.....	23
5.5.8	LNG Carrier Collision.....	24
5.5.9	NGL Product Vessel Collision	24
5.6	Terminal QRA	24
5.7	Public Safety	25
References.....		27

Appendices

Appendix A Clear Seas Data

List of Tables

Table 1 - Summary of LNG Carrier casualty types 1993 - 2021, Lloyd’s List Intelligence.....	9
Table 2 - Transportation Safety Board of Canada occurrence ranking system	11
Table 3 – Pacific Pilotage Authority incident data.....	12
Table 4 - Clear Seas occurrences within 10 nm of the selected marine route.....	13
Table 5 – Estimated incident return periods (in years).....	19
Table 6 – Estimated unmitigated return periods of major LNG incidents and LNG cargo release.....	20

List of Figures

Figure 1 - Overview of the selected marine route (Canadian Hydrographic Service Chart 3002, depths are in fathoms and feet).....	2
Figure 2 – Transportation Safety Board of Canada marine occurrence history for the BC Coast (2001 to 2021, for Class 2,3 and 4 only)	12
Figure 3 - Clear Seas local incident data.....	13

Abbreviations

Abbreviation	Description
°C	degrees Celsius
ABS	American Bureau of Shipping
ADCP	acoustic doppler current profiler
AIS	automatic identification system
AIS ATON	automatic identification system aid to navigation
AK	Alaska
ANSI	American National Standards Institute
ARI	average recurrence interval
ATON	aids to navigation
BC	British Columbia
BCCP	British Columbia Coast Pilots Ltd.
BCER	BC Energy Regulator
BNWAS	bridge navigational watch alarm system
BOG	boil off gas
BV	Bureau Veritas
CCG	Canadian Coast Guard
CHS	Canadian Hydrographic Services
CMB	continuous marine broadcast
CPAs	Compulsory Pilotage Areas
DAS	docking assist system
deg	degree
DFO	Fisheries and Oceans Canada
DNV	Det Norske Veritas
dwt	deadweight tonnage
EA	environmental assessment
ECCC	Environment and Climate Change Canada
ECDIS	electronic chart display and information system
EDG	emergency diesel generators
EEBD	Emergency Escape Breathing Device
EMSA	enhanced maritime situation awareness
ENC	electronic navigational chart
EOC	Emergency Operations Centre
EPIRB	emergency position-indicating radio beacon

Abbreviation	Description
ERS	emergency release system
ESD	emergency shut down
ETA	estimated time of arrival
EU	environmental unit
FEED	front-end engineering design
FFA	fire fighting appliances
FLNG	floating liquefaction, storage, and off-loading barge
FMBS	full mission bridge simulation
FMO	Federal Monitoring Officer
FSA	Formal Safety Assessment
FSRU	floating storage and regassification units
GMDSS	Global Maritime Distress, and Safety System
GNSS	Global Navigation Satellite System
GTT	Gaztransport and Technigaz
HFO	heavy fuel oil
HNS	hazardous and noxious substances
Hs	significant wave height
IACS	International Association of Classification Societies
IALA	International Association of Marine Aids to Navigation and Lighthouse Authorities
ICS	Incident Command System
IGC Code	<i>International Code for the Construction and Equipment of Ships Carrying Liquefied Gases in Bulk</i>
ILO	International Labour Organization
IMO	International Maritime Organization
ISGOTT	<i>International Safety Guide for Oil Tankers and Terminals</i>
ISM	International Safety Management
ISPS	<i>International Ship and Port Facility Security Code</i>
kHz	kilohertz
km	kilometre
kn	knot
LBP	length between perpendiculars
LFL	lower flammability limit
LLWLT	lower, low water, large tide
LNG	liquefied natural gas
LOA	length overall
LOS	level of service
LPG	liquefied petroleum gas

Abbreviation	Description
LR	Lloyd's Register
LSA	life-saving appliances
LSIR	location specific individual risk
LTA	line throwing appliance
m	metre
m	metres per second
m ²	square metres
m ³	cubic metres
m ³	cubic metres
m ³ / hour	cubic metres per hour
MARPOL	<i>International Convention for the Prevention of Pollution of Ships</i>
MCTS	Marine Communications and Traffic Services
MDO	marine diesel oil
MGO	marine gas oil
MOF	material off-loading facility
MOU	Memorandum of Understanding
MSI	Marine Safety Inspectors
MSOC	Marine Security Operations Centre
MTBE	methyl tertiary butyl ether
mtpa	million tonnes per annum
NASP	National Surveillance Aerial Program
NAVTEX	Narrow Band Direct Printing Telegraphy
NAVWARN	navigational warnings
NGL	natural gas liquid
NK	Nippon Kaiji Kyokai
NLG	Nisga'a Lisims Government
NLS	Noxious Liquid Substances
NOA	notice of arrival
North Coast	north coast of British Columbia
NOTMAR	Notices to Mariners
NRA	BCCP / PPA Navigational Risk Assessment
NSA	navigation safety assessment
NW	northwest
OCIMF	Oil Companies International Marine Forum
ODAS	ocean data acquisition system
OGAA	<i>Oil and Gas Activities Act</i>

Abbreviation	Description
OPP	Oceans Protection Plan
OPRC	<i>International Convention on Oil Pollution Preparedness, Response and Co-operation</i>
OSC	On-Scene Commander
P&I	protection and indemnity (insurance)
P&I	protection and indemnity
PAH	polycyclic aromatic hydrocarbons
PAIR	Pre-Arrival Information Reports
PIANC	World Association for Waterborne Transport Infrastructure
PMS	planned maintenance system
PORCP	National Places of Refuge Contingency Plan
PPA	Pacific Pilotage Authority
PPO	Pollution Prevention Officer
PPU	portable pilot units
PRPA	Prince Rupert Port Authority
PRPRCP	<i>Pacific Region Places of Refuge Contingency Plan</i>
PSC	Port State Control
QCDC	quick connect disconnect couplers
QRA	quantitative risk assessment
QRH	quick release hooks
QSCS	Quality System Certification Scheme
racon	radar beacon
RNC	raster navigational chart
RO	recognized organization (with respect to flag state affairs)
RO	response organization (with respect to spill response)
RT	radiotelephony
s	seconds
SAR	search and rescue
SIGTTO	Society of International Gas Tanker and Terminal Operators
SIRE	Ship Inspection Report Programme
SMPEP	Shipboard Marine Pollution Emergency Plan
SOLAS	<i>International Convention for the Safety of Life at Sea (SOLAS), 1974</i>
SOPEP	Shipboard Oil Pollution Emergency Plan
SOPF	Ship-source Oil Pollution Fund
SSL	ship-shore link
STCW	<i>International Convention on Training, Certification, and Watchkeeping for Seafarers</i>
SW	southwest

Abbreviation	Description
SWL	safe working load
t	metric tonne (equal to 1,000 kilograms)
TCMSS	Transport Canada Marine Safety and Security
TERMPOL	Technical Review Process of Marine Terminal Systems and Transshipment Sites
TOM	Terminal Operations Manual
Tp	peak wave period
TSB	Transportation Safety Board of Canada
UKC	underkeel clearance
US	United States
V-ATON	virtual aid to navigation
VDR	voyage data recorder
VHF	very high frequency
VLSFO	very low sulphur fuel oil
VTS	Vessel Traffic Services
WCMRC	Western Canada Marine Response Corporation

Preface

A Navigation Safety Assessment (NSA) is part of the Application. The NSA is an opportunity to review the Ksi Lisims LNG Project and determine whether additional resources (e.g., pilots), controls or infrastructure (e.g., navigational aids) are required and when they need to be in place. The NSA studies make-up Appendix E and findings inform Section 9 Malfunctions and Accidents and other sections (e.g., Section 7.11 Marine Use). Section 9.1.2 Planning provides a list and high-level description of the NSA studies. Additional navigation simulations will be completed before the start of operations and will be the subject of approval conditions.

1 Introduction

The *Casualty Data and Risk Analysis Report* is part of the Navigation Safety Assessment (NSA) for Ksi Lisims LNG – Natural Gas Liquefaction and Marine Terminal Project (the Project). An overview of the Project, including the selected marine route for liquefied natural gas (LNG) carriers and natural gas liquid (NGL) product vessels, is provided in the *Marine Route Report* [1].

The *Casualty Data and Risk Analysis Report* includes four sections:

- 1) Project background
- 2) An overview of marine and LNG carrier safety initiatives globally and in Canada
- 3) A global and local casualty data survey (casualty types are defined in Section 4)
- 4) An assessment of risks from Project marine shipping and marine terminal operations

1.1 Casualty Data

The casualty data survey examines incident frequencies from:

- A global casualty data survey of worldwide shipping, and
- A regional casualty data survey of shipping in Canadian waters and on the North Coast

The purpose of the casualty data is threefold:

- The casualty data survey confirms whether the incident frequencies in the risk analysis (see Section 5) are reasonable and the consequences credible
- Information from the global casualty data survey gauges the effectiveness of initiatives to promote safe shipping and indicates where further risk mitigation may be warranted
- Information from the regional casualty data survey assesses hazards on the North Coast that may require added study or risk mitigation

1.2 Risk Analysis

The risk analysis in Section 5 examines the credible risk of incidents involving design LNG carriers and NGL product vessels in transit and at the marine terminal. The conditional probabilities of cargo releases are also estimated. The estimated incident frequencies and conditional probabilities of cargo releases presented are based on a literature review of studies for the North Coast. Worst-case credible events are estimated for emergency planning purposes and to ensure sufficient resources are available in the unlikely event an incident causes a release of cargo or fuel.

2 Project Background

The Project is a floating natural gas liquefaction facility and marine terminal at Wil Milit on the North Coast at the northern end of Pearse Island. The Project Site (Site) is approximately 15 km west of the Nisga'a community of Gingolx (see Figure 1). LNG carriers and NGL product vessels will transit a marine route from Dixon Entrance to Portland Canal to reach the marine terminal (see Figure 1).

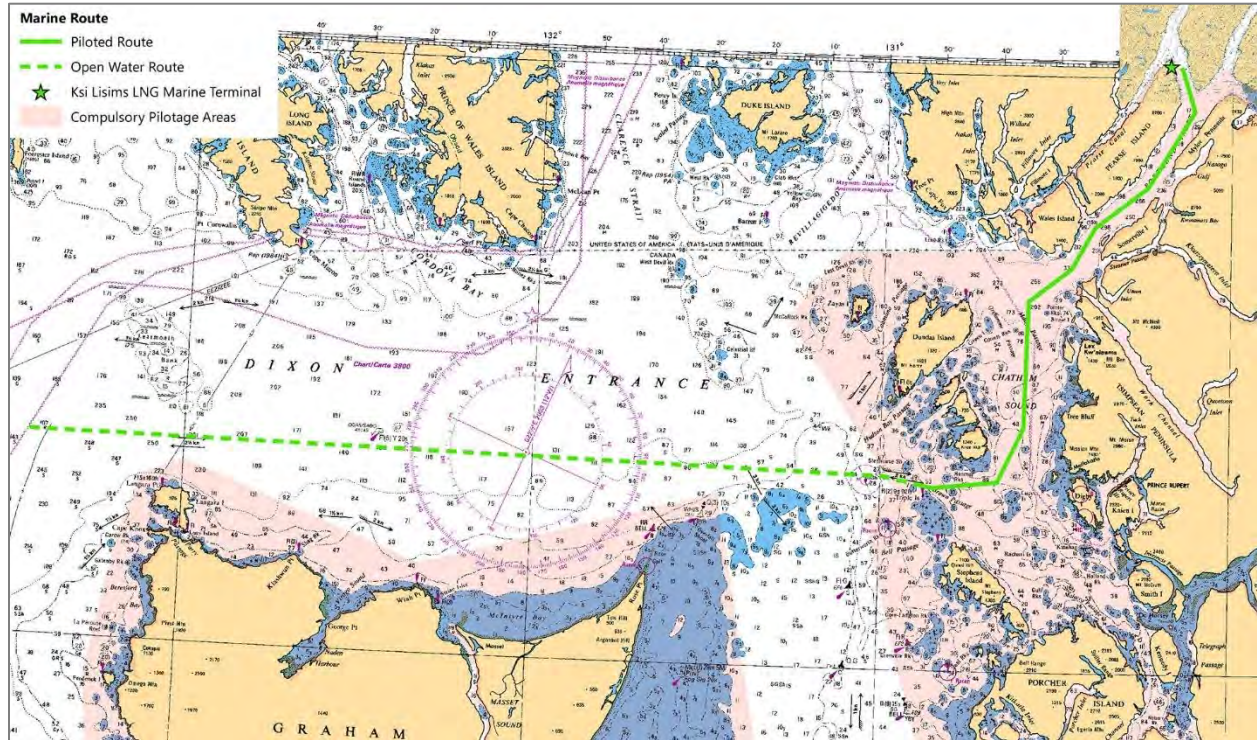

Figure 1 - Overview of the selected marine route (Canadian Hydrographic Service Chart 3002, depths are in fathoms and feet)

The selected marine route is from Dixon Entrance to Triple Island pilot boarding station, through Brown Passage, to Chatham Sound, Main Passage, Portland Inlet and Portland Canal, ending at Wil Milit on Pearse Island.

The selected marine route through Portland Inlet and Portland Canal has been used by commercial vessels up to Panamax size for decades without a recorded incident. Most vessel traffic through Portland Canal is tugs and piloted vessels headed to the Port of Stewart, BC. The portion of the route through Dixon Entrance, Brown Passage and Chatham Sound is shared with vessels calling at the Port of Prince Rupert, including container ships larger than the design LNG carriers.

2.1 Project Design Vessel Specifications

Parameters for the design LNG carriers and NGL product vessels are in the *Vessel Specification Report* [2]. Design LNG carriers range from approximately 140,000 m³ to of 217,000 m³ capacity. LNG carriers calling at the marine terminal are not forecast to exceed approximately 180,000 m³ capacity. The LNG facility is being designed for LNG carriers up to 217,000 m³ capacity as a future provision. Design NGL product vessels range from approximately 5,000 to 30,000 dwt capacity.

The Project estimates approximately 140 to 160 LNG carrier calls per year, depending on the size of the LNG carriers used and the total LNG produced by the Project. Approximately 8 to 12 NGL product vessels are forecast to call at the marine terminal each year.

2.2 Preliminary Mitigation Measures

Risk mitigation measures generally fall into two categories:

- **Frequency mitigation measures** - mitigate the likelihood of an incident (e.g., collision) or probability of an adverse effect (e.g., double hulls to prevent the release of cargo in the event of a collision)
- **Consequence mitigation measures** - mitigate consequences should an incident or adverse effect occur (e.g., resources for emergency response)

The Project is committed to further study of both frequency mitigation (e.g., tugs and ATONs) and consequence mitigation measures (e.g., emergency response planning).

Mitigation measures can be technological, involving improvements in the design, construction, and maintenance of LNG carriers, NGL product vessels, floating liquefaction, storage, and off-loading barges (FLNGs), tugs, the LNG facility, or other infrastructure. Mitigation measures can also be focused on operations, including training and controls to mitigate how people's actions contribute to an incident. Implementing mitigation measures may be the Project's responsibility (e.g., the provision of tugs), a third party's responsibility (e.g., pilots), or a shared responsibility between the Project and applicable third parties or government agencies.

Risk mitigation measures for the Project include both statutory requirements and project-specific measures. Risk mitigation measures include, but are not limited to, the following:

- 1) The Project will have an acceptance program for LNG carriers and NGL product vessels. The acceptance program includes a vetting component. The vetting process involves checking LNG carriers and NGL product vessels have up-to-date certifications and have not been flagged by other operators or agencies as out of compliance with industry requirements. The Project's vetting will use the Ship Inspection Report (SIRE) Programme administered by the Oil Companies International Marine Forum (OCIMF)
- 2) LNG carriers and NGL product vessels will use an existing marine route from Dixon Entrance to the Triple Island pilot boarding station, through Brown Passage, to Chatham Sound, Main Passage, Portland Inlet and Portland Canal, ending at Wil Milit on Pearse Island, unless a deviation is required for safety or operational requirements, as determined by the LNG carrier captain or pilot
- 3) Within the Compulsory Pilotage Areas defined in the *Pilotage Act* (i.e., between the Triple Island pilot boarding station and the marine terminal) LNG carriers and NGL product vessels will be under the guidance of one or more pilots from the British Columbia Coast Pilots Ltd. (BCCP)
- 4) Mariners will be informed by Canadian Coast Guard (CCG) Marine Communications and Traffic Services (MCTS) of LNG carriers and NGL product vessels transiting to and from the marine terminal within the Prince Rupert MCTS VTS zone boundary. The Project will work with applicable agencies to investigate the feasibility of added communication services along the marine route
- 5) The recommended speed profile for LNG carriers and NGL product vessels along the marine route will be informed by full mission bridge simulation (FMBS) and the joint British Columbia Coast Pilots Ltd. (BCCP) / Pacific Pilotage Authority (PPA) Navigational Risk Assessment (NRA)
- 6) The Project will work with applicable agencies to investigate the feasibility of added communication services and aids to navigation (ATON), where necessary, along the marine route

- 7) Tug specifications, berthing procedures for the marine terminal, marine terminal ATON, and operating limits for the marine terminal will be determined during detailed project planning and informed by the BCCP / PPA NRA
- 8) The Terminal Operations Manual (TOM) will be based on industry best practices and incorporate the International Safety Guide for Oil Tankers and Terminals (ISGOTT) and Society of International Gas Tanker and Terminal Operators (SIGTTO) ship/shore guidelines and checklists
- 9) In addition to complying with regulatory requirements, the Project will require LNG carriers and NGL product vessels to follow specific operational procedures for safe cargo management onboard the ship at the marine terminal. These procedures will be consistent with industry guidelines, including:
 - *Guide to Contingency Planning for Marine Terminals Handling Liquefied Gases in Bulk* published by SIGTTO
 - *Support Craft at Liquefied Gas Facilities. Principles of Emergency Response and Protection* published by SIGTTO
 - *Contingency planning for spills on water* published by ipieca"
- 10) The Project will prepare an Emergency Response Plan for the entire LNG facility, including the marine terminal, as required under the *Emergency Management Regulation* under the *Oil and Gas Activities Act* (OGAA). The Emergency Response Plan will include components such as emergency response training, communications, compliance monitoring, and exercises and drills. The Project will provide the Emergency Response Plan to Transport Canada and the CCG at least six months before start of operations
- 11) The Project will subscribe to Western Canada Marine Response Corporation (WCMRC) and will utilize WCMRC's training, contingency plan testing and associated services
- 12) Tugs will be required to be outfitted with firefighting and spill response equipment. Tug services contracts will require that the crews onboard the tugs are trained in first response, including firefighting, deployment of oil spill response equipment and other emergency procedures
- 13) Further safety assessment will be completed before the start of operations and will be the subject of certificate conditions. This will include the BCCP/PPA NRA. This work will inform escort tug requirements, tug specifications, and speed profiles for the design LNG carriers and NGL product vessels. Project planning will be communicated in these documents, that will be provided to applicable agencies at least six months before operations begin:
 - Tug specifications
 - Terminal Operations Manual
 - Security plans
 - Training plans
 - Emergency Response Plan

These measures are part of or complement the global and Canadian safety explained in the next section.

3 LNG Carrier Safety

The total LNG carrier fleet was 700 vessels at the end of 2021. This included 48 floating storage and regasification units (FSRU) and 64 vessels (31 LNG bunker vessels and 33 LNG carriers) with less than 50,000 m³ capacity [3].

The LNG shipping industry has an excellent safety record. Since the first cargoes of LNG were shipped on a regular commercial basis in 1964, almost 100,000 shipments have been made without a single incident of LNG being lost through a breach or failure of LNG carrier cargo tanks [4].

The incident rate for gas carriers (the vessel category including LNG carriers) was 1.2% in 2020, below the world fleet average of 1.7% [5]. For the category representing NGL product vessels the incident rate was 1.4% in 2020, also below the world fleet average. Casualties from both LNG carriers and NGL product tankers are low relative to the number of vessels in service [5].

3.1 International Cooperation

Mitigation of marine risk begins with global efforts by the International Maritime Organization (IMO) to ensure “safe, secure, environmentally sound, efficient and sustainable shipping” [6]. Recent positive trends in marine safety worldwide can be attributed to modern class rules that have resulted in better vessels, increased digitalization and automation of ship systems and tighter regulatory supervision [7].

Implementing improvements to marine safety is facilitated by these groups:

- The IMO is a specialized agency of the United Nations, of which Canada is a member [8]
- The International Labour Organization (ILO) is also part of the United Nations and works to improve the safety and welfare of seafarers
- Classification Societies provide classification and statutory services and assistance to the maritime industry and regulatory bodies [9]
- Industry groups including, but not limited to:
 - Insurance groups including protection and indemnity (P&I) clubs and their umbrella organizations (e.g., the International Group of P&I Clubs)
 - SIGTTO
 - International Group of Liquefied Natural Gas Importers (GIIGNL)
 - International Gas Union (IGU)
 - The International Chamber of Shipping
 - The Shipping Federation of Canada
 - British Columbia Chamber of Shipping
 - Clear Seas Centre for Responsible Marine Shipping, and
 - Other non-governmental groups
- Flag States and the role played by Recognized Organizations (i.e., Classification Societies)
- Port States and the memorandum of understandings (MOUs) they are a part of (e.g., the Tokyo MOU)
- Electronic Quality Shipping Information Systems (EQUASIS), providing unbiased safety-related information on ships
- The Government of Canada including Transport Canada, Fisheries and Oceans Canada, the CCG, Environment and Climate Change Canada, Natural Resources Canada, and Health Canada, federal agencies (e.g., and port authorities) and crown corporations (e.g., PPA)

3.2 Canadian Initiatives

Canada, as a member of the IMO, is signatory to international maritime conventions and has been a leading advocate for change at the global level (e.g., Canada helped create the *International Convention for the Control and Management of Ships' Ballast Water and Sediments*) and implementing new conventions (e.g., Canada is one of the first signatories of the *International Convention on Liability and Compensation for Damage in Connection with the Carriage of Hazardous and Noxious Substances by Sea*). In 2016 the government announced the Oceans Protection Plan (OPP) to ensure Canada's oceans are cleaner, healthier and safer [10]. The purpose of the OPP is to:

- Establish a world-leading marine safety system
- Preserve and restore marine ecosystems
- Create stronger Indigenous partnerships and engage coastal communities
- Create a stronger evidence base to improve marine response and decision-making

Implementing the OPP is shared by Transport Canada, Fisheries and Oceans Canada, the CCG, Environment and Climate Change Canada, Natural Resources Canada, and Health Canada, with support from Public Services and Procurement Canada and Global Affairs Canada.

OPP initiatives relevant to Project planning and the region where the marine route and Site are located, include:

- Increasing the CCG presence on all coasts, including modern environmental response equipment, communications tools, radar, new search and rescue stations, and improved infrastructure [11]
- Constructing six new radars to provide a more reliable and accurate picture of traffic in the waters off BC [12]
- Leasing two offshore vessels capable of towing large ships on the West Coast [13]
- Installing towing equipment on all major CCG vessels [13]
- Developing the National Strategy on Emergency Towing, a long-term national approach for marine emergency towing, which will include recommendations on how to best meet emergency towing requirements on all coasts [14]
- Improving navigation products and services for mariners in sensitive coastal areas, and high-traffic commercial ports and waterways. These improvements help mariners with updated charts, weather services, communications and radar [11]
- Enhanced wind strength and direction and wave height forecasts [15]
- Delivering training and funding to Indigenous communities to purchase emergency response boats and equipment to facilitate participation in the CCG Auxiliary [11]
- Co-developing enhanced maritime situation awareness (EMSA) local waterways near real-time information system with 13 Indigenous communities [11]
- Forming an agreement between Canada and 17 Pacific North Coast First Nations to advance collaborative oceans governance and management [16] [17]
- Signing the Reconciliation Framework Agreements For Bioregional Oceans Management and Protection, and the OPP Commitment to Action and Results, with the First Nations Fisheries Council, to better coordinate and collaborate on ocean management and protection priorities [11]
- Training 4,500 people across Canada on emergency programs [11]
- Supporting 750 individuals, including women, Indigenous Peoples, and Northerners, to graduate from specialized training to qualify for jobs in the marine industry [16]

- Amending the *Canada Shipping Act, 2001* and other acts to enable the proactive management of marine emergencies and cover more types of marine pollution [16]
- Modernizing Canada's Ship-source Oil Pollution Fund so the polluter pays and making unlimited compensation available to those affected by an oil spill [16]
- Developing a national program to respond to hazardous and noxious substances (HNS) releases [18]. This includes enhanced HNS risk assessments, research and development, and implementing the *2010 HNS Convention* [18]
- Completing hydrographic surveys of five priority ports collecting data on the seafloor to create better navigation charts: Prince Rupert, Stewart, Port Alberni, Crofton, and Vancouver, BC [12]

3.3 Regional Initiatives

Other groups, including the Prince Rupert Port Authority (PRPA), have also made enhancements on the North Coast, including investments in navigational technology such as shore-based radar, Automatic Identification System (AIS) installations, enhanced navigational aids and live wind, wave, current, and tide sensors to ensure real-time awareness of vessels and their environment [19].

4 Casualty Data Survey

This section summarizes data for marine occurrences globally and in Canada. Marine casualty reporting worldwide commonly refers to these terms:

- Casualty
- Accident
- Incident
- Near miss or dangerous occurrence

Organizations responsible for incident reporting, worldwide and in Canada include:

- IMO
- Transport Canada
- Transportation Safety Board of Canada
- PPA
- Third parties (i.e., Lloyds List Intelligence)

The Code of International Standards and Recommended Practices for a Safety Investigation into a Marine Casualty or Marine Incident (Casualty Investigation Code) makes it mandatory for member states (i.e., Canada) to report incidents consistently to the IMO.

Global casualty data in this report for LNG carriers and NGL vessels is from the “Seasearcher” database maintained by Lloyd’s List Intelligence [20]. Lloyds List Intelligence uses a variety of sources to obtain data on marine incidents for all AIS Class A merchant vessels and fishing vessels of over 50 gross tonnage worldwide [21]. The Seasearcher database has been used to extract all incidents related to LNG carriers and NGL product vessels over the past 20 years.

Reporting of marine incidents in Canada is required by Transport Canada under the Shipping Casualties Reporting Regulations [22] under the *Canada Shipping Act, 2001* [23] and by the Transportation Safety Board of Canada (TSB) under the Transportation Safety Board Regulations [24] under the *Canadian Transportation Accident Investigation and Safety Board Act*.

The TSB maintains a database of all occurrences they investigate, or are informed of, and compiles annual statistical studies of marine transportation occurrences. The PPA also tracks incidents within the compulsory pilotage areas.

4.1 Canadian Context

4.1.1 LNG Carriers

Canaport LNG in Saint John, New Brunswick is Canada’s only operating LNG terminal and is for import only [25]. Canaport LNG has been operating since 2009 [26]. Tilbury LNG in BC has been operating as a peak-shaving facility since 1971 [27]. In 2017 Tilbury LNG exported its first cargo using ISO containers [28]. There are no other operational marine LNG terminals in Canada.

Both LNG Canada [29] and Woodfibre LNG [30] are forecast to enter service before the Project is operational. This will provide marine operators, government agencies, Indigenous groups and other stakeholders with valuable experience that will carry over to the Project.

There have been no serious incidents related to gas carriers according to TSB data. The only incidents involving gas carriers, reported to the TSB, include three incidents involving liquid propane gas (LPG)

carriers at anchor in the Port of Prince Rupert and an LNG carrier at anchor off New Brunswick. LNG carriers and NGL product vessels will not anchor as part of normal Project operations. Delays will be managed through delaying departure from the marine terminal, timing of arrival at the pilot boarding station or adjusting transit speed.

4.1.2 NGL Product Vessels

Refined products have been shipped on North Coast, most recently to the former Methanex methanol plant and marine terminal in Kitimat. Starting in 1982 the facility exported methanol, ammonia, and the gasoline additive methyl tertiary butyl ether (MTBE) in varying quantities in different years. In 2005, the Methanex plant ceased production and the marine terminal began importing methanol to serve existing customers. In 2006, the marine terminal also began importing condensate. In 2008, 13 import vessels carrying methanol and 11 vessels carrying condensate called at the marine terminal.

No condensate has been shipped to Kitimat in close to 10 years¹. The trend is vessels transporting condensate are few and sporadic. Data from 1995 collated by the TSB lists no incidents involving product vessels transporting condensate.

4.2 Global Casualty Data

4.2.1 Global Trends

Worldwide there has been continuous improvement in marine safety and a decline in marine occurrences. Casualties worldwide from all shipping declined from 1,922 in 2012 to 1,537 by 2021 [7]. Casualties causing losses have declined from 132 in 2012 to 58 in 2020 [7]. This is a 56% drop in the annual number of losses per year as the number of ships in the global fleet has grown over the same period from 116,000 to 130,175, or an increase of 16% [5]. The improvement in shipping safety is due to increased digitalization and automation of ship systems, modern class rules, better vessels and tighter regulatory supervision [7] [5].

4.2.2 LNG Carriers

Casualty statistics in the Seasearcher database for LNG carriers include 116 casualties dating to 1993. Over 60% are minor casualties. A summary of the casualties that have occurred are in Table 1.

Table 1 - Summary of LNG Carrier casualty types 1993 - 2021, Lloyd's List Intelligence

Casualty Type	All Casualties	Serious Casualties
Fire / explosion	11	2
Collision (e.g., involving two vessels)	21	13
Contact (e.g., contact with fixed infrastructure)	9	1
Foundered (e.g., sunk, submerged)	0	0

¹ In late 2011, Shell bought the legacy Methanex facilities from Cenovus Energy Corp. The facilities were last used to import condensate for transport by rail. According to Google Earth, by July 2013 all tanks and rail loading infrastructure at the legacy Methanex site had been removed.

Casualty Type	All Casualties	Serious Casualties
Machinery damage / failure (e.g., lost rudder, fouled propellor)	35	19
Hull damage (e.g., holed, cracks, structural failure)	3	1
Piracy	19	3
Miscellaneous	9	1
Wrecked / stranded (i.e., aground)	9	4
Arrests / seizures / detained	0	0
Labour dispute	0	0
War loss / damage during hostilities	0	0
Missing / overdue	0	0
Total	116	44

The LNG shipping industry has an excellent safety record. Despite several groundings and collisions involving LNG carriers there has not been a single incident of LNG being lost through a breach or failure of LNG carrier cargo tanks.

There have been a few grounding incidents, but none caused loss of cargo [4] or the necessity to release cargo [32]. This demonstrates the effectiveness of LNG carrier double hulls at preventing the release of cargo in the event of a collision or grounding. For information on LNG carrier hull construction refer to the *Vessel Specifications Report* [2].

LNG carriers, compared to most other types of marine shipping, have a lower incident frequency [32]. The lower incident frequency is believed to be due to:

- The high standards to which LNG carriers are designed, maintained, and operated [4]. Refer to the *Vessel Specification Report* [2] for further details
- LNG carriers are, on average, newer and more technically advanced than other merchant vessels. Over 55% of the fleet is less than 10 years old, and over 80% is less than 15 years old

Many of the LNG carriers to call on the marine terminal will likely be new-build ships designed and contracted specifically for the Project.

4.2.3 NGL Product Vessels

The Seasearcher database was reviewed for casualties that fall within the specified NGL product vessel types and size range. The average serious incident frequency for NGL product vessel types is 1 per 100 vessels in the last decade. Spills of condensate in the marine environment are uncommon compared with other types of oil spills [33]. However, there has been one total loss of an NGL product vessel. On January 6, 2018, the Sanchi was involved in a collision in the East China Sea [34]. The contributing factors to the Sanchi incident were related to vessel operations, not technical failures (e.g., hull failure or machinery failure) [34] [35]. The Sanchi was operating in an area of higher traffic density and was not under pilotage. A similar incident likely could not occur in Canadian waters.

4.3 Local Casualty Data

4.3.1 Transportation Safety Board of Canada

The TSB maintains a database of all occurrences the TSB investigates or is informed of. The TSB compiles annual statistical studies of marine transportation occurrences. The TSB uses the six-point classification system in Table 2 to rank the severity of the occurrences recorded [36].

Table 2 - Transportation Safety Board of Canada occurrence ranking system

Class	Description
1	Occurrences with common characteristics that have formed a pattern over time. This pattern is made of one or more significant safety risks identified by the TSB.
2	Has significant consequences that attract a high level of public interest across Canada or internationally. Many people are affected, some of whom may be fatally or seriously injured. There may be a large release of dangerous goods. There is significant damage to property and / or the environment.
3	Significant consequences that attract a high level of public interest. It may involve multiple fatalities and / or serious injuries. There may be a medium-sized release of dangerous goods. There is moderate to significant damage to property and / or the environment.
4	Some important consequences. It may involve fatalities or serious injuries. There may be a small release of dangerous goods. There is moderate to minor damage to property and / or the environment.
5	Little likelihood of identifying new safety lessons that will advance transportation safety. The occurrence may involve fatalities and / or serious injuries. There is little or no release of dangerous goods. There is minimal damage to property or the environment.
6	A transportation occurrence that occurs outside of Canada and might be investigated by a foreign investigation body. This includes investigations led by another country where the TSB has to participate or provide assistance.

TSB data for the BC Coast from the past two decades was assessed. The data shows there have been no Class 1 occurrences on the BC Coast over the period of 2001 to 2021. Over 98% of the entries are Class 5 which are low-consequence events often related to smaller vessels. There was one Class 2 event in 2021 which was a fire aboard at container vessel at Constance Bank. The frequency of the remaining Class 2, 3 and 4 occurrences are shown in Figure 2.



Figure 2 – Transportation Safety Board of Canada marine occurrence history for the BC Coast (2001 to 2021, for Class 2,3 and 4 only)

On average, there have been approximately six Class 2, 3 or 4 incidents on the BC Coast each year. There is no trend in the TSB data. It is noted that the Transportation Safety Board Regulations were updated in 2014, clarifying reporting requirements and making it easier to report incidents [24].

4.3.2 Pacific Pilotage Authority Incident Reporting

The PPA tracks incidents using a three-point severity classification system with Class A being the most severe and Class C the least severe. Incidents recorded by the PPA over the past seven years are in Table 3. There were seven Class C incidents in 2021 including: four berthing incidents at terminals, two incidents with damage to gangways, and one incident with damage to a dive boat.

Table 3 – Pacific Pilotage Authority incident data

Year	Total Assignments	Class A	Class B	Class C	Total Incidents
2015	12,359	-	-	1	1
2016	12,646	-	-	5	5
2017	13,469	-	-	4	4
2018	13,465	-	-	5	5
2019	13,391	-	2	4	6
2020	12,736	-	-	13	13
2021	12,089	-	-	7	7

4.3.3 Clear Seas Centre for Responsible Marine Shipping

The Clear Seas Centre for Responsible Marine Shipping (Clear Seas) is an independent organization that supports safe and sustainable marine shipping in Canada. As part of their report *Maritime Commercial*

Incidents and Accidents, Clear Seas collated publicly available marine occurrence data from the TSB and from the US Coast Guard [37]. Marine occurrence records from January 2009 to December 2018 were gathered [37]. Clear Seas published the data as an interactive web-based map [37].

A plot of incidents from the Clear Seas data, near the selected marine shipping route, is in Figure 3. Within 10 nautical miles (nm) of the marine route (outline in Figure 3) there were 35 marine incidents. These incidents are summarized in Table 4 and Appendix A.

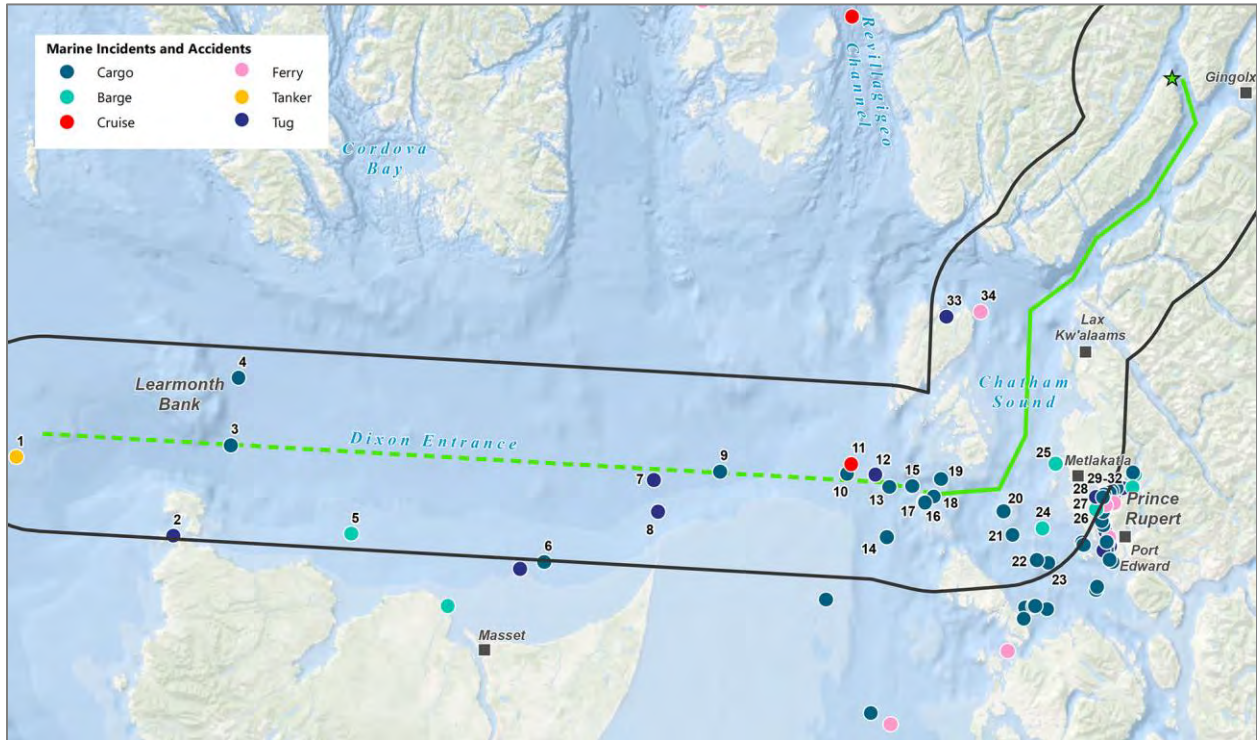

Figure 3 - Clear Seas local incident data

Table 4 - Clear Seas occurrences within 10 nm of the selected marine route

Occurrence Type	Number of Occurrences
Risk of Incident	10
Total Failure of any System	18
Sustains Damage Render Unseaworthy / Unfit for Purpose	3
Collision	1
Fire / Explosion	2
Total	35

Most incidents in the Clear Seas dataset are dangerous occurrences (i.e., less serious casualties). The data includes one incident entry for a tanker in 2018, where the “Palanca Muscat” dropped anchor in McIntyre Bay to complete engine work.

4.4 Terminal Incidents

Major accidents at LNG facilities are rare. LNG is not stored under pressure, LNG is not explosive, and LNG vapour is not explosive in an unconfined environment. Since the start of LNG operations in 1941, there have only been a few serious incidents at LNG terminals [38].

4.5 Casualty Data Summary

The LNG shipping industry has an excellent safety record. Since the first cargoes of LNG were shipped on a regular commercial basis in 1964, almost 100,000 shipments have been made without a single incident of LNG being lost through a breach or failure of the ship’s tanks [4]. LNG carriers and NGL product vessels have a lower frequency of incidents compared to other vessel types and the overall fleet of commercial vessels globally. Globally, shipping safety continues to improve.

Most of the casualty data gathered in Canada and for the area of the selected marine route are incidents involving smaller vessels not under pilotage. Low traffic volumes along the North Coast mean there have been relatively few incidents recorded compared to other areas of Canada. No serious or very serious incidents have been recorded within 10 nm of the marine route in the past two decades.

The casualty data recorded for the North Coast shows the highest frequency of occurrences along the marine route is in Chatham Sound and Brown Passage. This finding is aligned with the *Marine Traffic Report* [39] and hazard identification (HAZID) findings described in Section 5.3. The most common incident is machinery / systems failure, consistent with worldwide data for all vessel types.

5 General Risk Analysis

5.1 Introduction

Marine shipping in Dixon Entrance and Chatham Sound has been studied by:

- Transport Canada
- The PRPA
- Other LNG terminal proponents

Relevant studies include:

- *Marine Navigational and Anchorage Areas Risk Assessment Report* [40]
- *Prince Rupert Ship Routing Advisory Study* [41]
- *Prince Rupert Marine Risk Assessment* [42]
- *Prince Rupert Navigational Risk Assessment Report* [43]
- *TERMPOL Review Report for Pacific Northwest LNG* [44]
- *TERMPOL Review Report for Kitimat LNG* [45]
- *TERMPOL Review Report for LNG Canada* [46]

For the LNG export projects that completed the TERMPOL Review Process and / or received an environmental assessment (EA) certificate, reports by reviewing or approving agencies concluded:

- Canada's regulatory regime would provide effective oversight for the marine transportation components of the projects
- The projects fairly represented the navigation and operational risks that could cause an accidental loss of containment of cargo and key mitigations to reduce those risks.

5.2 Risk Analysis Methodology

The IMO's Formal Safety Assessment (FSA) [57] supports the methodology for the Project's risk analysis. The FSA is a structured and systematic methodology that includes these five steps [57]:

- 1) Identification of hazards (i.e., a list of all relevant accident scenarios with potential causes and outcomes)
- 2) Risk assessment (i.e., evaluation of risk factors and likelihood)
- 3) Risk mitigation options (i.e., devising regulatory measures to control and reduce the identified risks)
- 4) Cost benefit assessment (i.e., determining cost effectiveness of each risk control option)
- 5) Recommendations for decision-making (i.e., information about the hazards, their associated risks, and the cost effectiveness of alternative risk control options)

A hazard is something (e.g., an object, a property of a substance, a phenomenon or an activity) that can cause adverse effects [47]. Hazards can be categorized into these groups [48]:

- Natural Hazards such as strong currents, storms, shallow waters, and other natural phenomena
- Built Hazards such as bridges or other stationary structures as well as other vessels (i.e., marine traffic)
- Human Hazards such as errors or omissions by marine companies or organizations, ship's masters and crews or pilots
- Technical Hazards such as loss of navigation aids, loss of power or equipment failures or obsolescence of equipment

- Economic Hazards such as inflation or business cycles that can negatively affect internal policies and practices such as training and vessel maintenance

HAZID workshops have been completed for past projects in the region [40]. The applicable findings from these HAZIDs are described in Section 5.3.

As explained in the *Vessel Specifications Report* [2], there are differences in the characteristics of the design LNG carriers and NGL product vessels. Some hazards (e.g., strong winds) will affect LNG carriers and NGL product vessels differently due to their different size, windage area and handling characteristics.

Hazards can cause marine incidents, including:

- Ship to ship collision
- Powered grounding (i.e., groundings which occur while the ship is under power)
- Drift grounding (i.e., groundings which occur when the ship has lost power)
- Structural failure / foundering while underway
- Fire / explosion while underway
- Ship collision with fixed marine structures (i.e., allision)
- Incidents related to improper cargo transfer

Likelihoods can be expressed as probabilities (e.g. "one in a thousand"), frequencies (e.g. "1,000 cases per year") or in a qualitative way (e.g. "negligible" or "significant") [47]. Often in marine risk analyses, the likelihood of incidents is expressed as frequencies per nautical mile. Each incident frequency is multiplied by the distance forecast to be travelled by LNG carriers along each segment of the selected marine route. This calculation provides an annual frequency for each incident type. The inverse of annual frequency is the average recurrence interval (ARI) or return period.

Section 5.3.1 estimates LNG incident frequencies. To be consistent with past studies, frequencies from the references in Section 5.1 were applied to the Project's forecast LNG shipping. Incident frequencies for NGL product vessels are not estimated. Given the lower number of condensate shipments (i.e., approximately 10 shipments per year rather than 150, in the case of LNG) the incident frequency for NGL product vessels would be much less than the incident frequency for LNG carriers.

Section 5.5 considers credible worst-case releases of cargo and fuel. Worst-case credible events are estimated for emergency planning purposes and to ensure sufficient resources are available in the unlikely event an incident causes a release of cargo or fuel.

Conditional probability is an important concept for marine risk analysis. The likelihood fuel or cargo is released is conditional on an incident (e.g., grounding) occurring. The likelihood fuel or cargo is released is the forecast incident frequency multiplied by the conditional probability there is also a release of fuel or cargo. This is important because while incidents involving LNG carriers have occurred, there has not been a single incident of LNG being lost through a breach or failure of an LNG carrier's cargo tanks.

The Project has completed a separate risk assessment of terminal facilities. The results are summarized in Section 5.4.

5.2.1 Risk Analysis – Next Steps

A further phase of safety assessment will be completed before the start of operations and will be the subject of certificate conditions. This phase will include:

- Terminal HAZID studies and hazard and operability studies (HAZOPs) will be completed as part of detailed project planning

- Navigation hazards, terminal berthing / deberthing, and tug services and specifications will be assessed as part of detailed project planning and the BCCP / PPA NRA
- As part of their regular level of service (LOS) reviews, the CCG will review hazards to navigation and the corresponding need for additional ATON
- Pilotage services in the region and required changes to operations will be reviewed by the PPA

Preliminary risk mitigation measures are outlined in Section 2.2.

5.3 Hazard Identification

The selected marine route can be divided into three sections, including:

- Dixon Entrance to Triple Islands
- Triple Islands to Portland Canal
- Portland Canal to the marine terminal

Hazards common to all route segments are described below, followed by the hazards for each section. Information on hazards can be found in the *Marine Navigational and Anchorage Areas Risk Assessment - Final Report* completed for the PRPA. The report references a HAZID workshop attended by representatives of the PRPA, Transport Canada, MCTS, PPA, BC Pilots, BC Ferries, several PRPA tenants, representatives of two Indigenous groups and several other stakeholders [40]. Many hazards described below were confirmed in the workshop.

Principal hazards common to the marine route include:

- Commercial fishing near the marine routes through Dixon Entrance to Chatham Sound
- Some fishing and recreational vessels are not equipped with AIS and cannot be detected by radar on larger commercial vessels
- There is tug and barge activity between Triple Islands and Chatham Sound (tug crews are generally well informed and resolve potential close situations with larger commercial vessels) [40]
- Adverse metocean conditions; visibility can be a challenge in summer and fall due to fog
- Mechanical issues onboard vessels
- Passing and crossing traffic

Principal hazards from Dixon Entrance to Triple Island include:

- Learmonth Bank
- Celestial Reef
- Langara Point and Haida Gwaii
- Rose Spit and Overfall Shoal
- Crossing traffic ahead of the Triple Island Pilot Boarding Station
- Drift grounding

Principal hazards from Triple Island to Portland Canal include:

- Projects in Prince Rupert and Kitimat will increase traffic through the Triple Island pilot boarding station and Chatham Sound
- The Triple Island Pilot Boarding Station is near navigation hazards including physical hazards (e.g., Triple Islands) and crossing traffic
- Hazards with ATON in relatively proximity to the marine route:
 - Triple Islands

- Stenhouse Shoal
- Hanmer Rocks
- Pointer Rocks
- Hazards with ATON not near the marine route:
 - Lucy Islands
 - Connis Rocks
 - Dundas Island and Melville Island and surrounding islands
- Moore Shoal may be a candidate for a future ATON
- Traffic to Lax Kw'alaams

Principal hazards from Portland Canal to the marine terminal include:

- Marine channel with islands and shoreline in relative proximity
- Outflow winds
- Vessel berthing and deberthing and striking or allision at the marine terminal

5.3.1 Hazard Mitigation

Hazards described in this section are mitigated by the over 100 regulations, 30 laws, and international agreements that govern marine safety in Canada [49]. Project-specific mitigations (see Section 2.2) will further mitigate hazards where necessary.

Principal mitigation measures include:

- The *Canada Shipping Act, 2001* and the regulations it contains
- The Collision Regulations [50] under the *Canada Shipping Act, 2001*
- Navigational Warnings (NAVWARNs) and Notices to Mariners (NOTMAR) published by the CCG [51]
- CCG MCTS and mandatory call-in points within the Prince Rupert MCTS VTS zone boundary
- Vessels equipped with AIS
- Existing ATON and ongoing LOS reviews by the CCG
- Passage planning and distance from physical hazards
- Sailing directions and charts published by the Canadian Hydrographic Service (CHS)
- Communication between vessels and pilot to pilot communication (for piloted vessels)
- Weather forecasting and delaying arrival or departure
- The CCG towing vessel stationed on the North Coast (subject to operational constraints)

Measures recommended in past studies for consideration include [40]:

- Encouraging more AIS to be installed on fishing and recreational vessels
- Improving the relationship between marine operators and the commercial / sport fishing industry
- Improving availability of wind data
- Studying alternative pilot boarding location(s) west of Triple Islands

5.4 Incident Frequencies

The marine incident types assessed include:

- Drift grounding
- Powered grounding

- Collision
- Foundering
- Fire and / or explosion

The base incident frequencies found in the references in Section 5.1 were often in units of “incidents per vessel-year” based on global casualty data. The base incident frequencies are converted to units of “incidents / nautical mile” using assumptions regarding how much time vessels spend nearshore and in areas of higher traffic density. Incident frequencies for the marine route have been considered for these segments:

- Dixon Entrance
- Brown Passage
- Chatham Sound
- Portland Inlet and Portland Canal

The first three segments have been studied in the references in Section 5.1, while Portland Inlet and Portland Canal have not been studied. However, risk assessments have been completed for other projects on the BC Coast with marine routes in coastal channels. These studies have been used to estimate incident frequencies for Portland Inlet and Portland Canal.

Each segment is considered regarding contributing factors affecting the different incident types, relative to global averages. A factor affecting collision is vessel traffic and therefore a route segment with traffic lower than global averages would be factored to also have a lower collision frequency. This step requires subjective input.

Forecasting the annual incident frequencies for each segment involves taking the base frequencies for each segment in units of “incidents / nautical mile” and multiplying them by the segment length and the number of Project design vessel movements per year (an average of 150 LNG carrier vessels and 10 NGL product vessels per year is assumed).

There is variation in frequencies between references and a range of inputs and assumptions have been assessed, resulting in the range of forecast frequencies in Table 5. The results in Table 5 are expressed in units of an ARI (or return period) in “years”, which is the inverse of the frequency (e.g., a grounding frequency of 0.01 incidents per year is equal to an ARI of 100 years).

Table 5 – Estimated incident return periods (in years)

Event	Powered Grounding	Drift Grounding	Collision	Foundering	Fire / Explosion
Incident	90 - 110	310 - 380	320 – 400	40,000 to 49,000	630 - 770

Groundings and collisions have the lowest ARI and, therefore, Project risk will be mitigated the most by measures that target grounding and collision incidents.

5.4.1 Conditional Probabilities

The incidents in Table 5 could have a range of consequences. To provide context on higher-consequence events, conditional probabilities of major damage or total loss and release of cargo are considered. The conditional probabilities are derived from global casualty data and then applied to the project-specific incident return periods in Table 5. The forecast frequencies considering the conditional probability of major damage / total loss and cargo release are in Table 6.

Table 6 – Estimated unmitigated return periods of major LNG incidents and LNG cargo release

Event	Powered Grounding [years]	Drift Grounding [years]	Collision [years]	Foundering [years]	Fire / Explosion [years]
Major damage or total loss	200 - 250	700 - 900	1,300 – 1,600	40,000 – 49,000	1,200 – 1,500
Cargo release	450 - 550	1,600 – 1,900	3,000 – 3,700	40,000 – 49,000	3,600 – 4,500

5.5 Consequence Assessment

This section examines the credible worst-case outcomes in terms of the release of LNG, condensate, or fuel. Past projects [52] have considered a range of potential accidents and malfunctions, including:

- LNG spill (at the marine terminal loading facilities)
- LNG and fuel releases from marine shipping incidents, including:
 - Groundings
 - Allision with the marine terminal
 - Collision with another vessel
- Fuel or hazardous material spill (at the marine terminal or during transport to the marine terminal)

5.5.1 Cargo and Fuel Properties

5.5.1.1 LNG Properties

LNG is natural gas in a liquid state. When natural gas is chilled to a temperature of approximately minus 160° C at atmospheric pressure, it becomes a clear, colourless, and odourless liquid. LNG is non-corrosive and non-toxic. However, due to its cold nature, it must be carefully handled. LNG in liquid form cannot combust and is not flammable. Natural gas from LNG can cause asphyxiation in an unventilated confined space [53].

The liquefaction process removes water, oxygen, carbon dioxide and sulphur compounds in the natural gas. This results in an LNG composition of mostly methane with small amounts of other hydrocarbons and nitrogen [53]. LNG is stored and transported at atmospheric pressure, so unless LNG is under pressure (e.g., pumped through a pipe), during a release it will flow and evaporate.

If LNG is released it will warm and turn back into a gas. Methane has a narrow flammability range outside which it cannot burn. The upper flammability limit of methane is 15% and the lower flammability limit is 5% by volume. When fuel concentration exceeds the upper flammability limit, methane cannot burn because too little oxygen is present. When concentrations are below the lower flammability limit, methane cannot burn because too little methane is present [54].

The most likely outcome, in the event of a LNG release that ignites, is a pool fire [55]. Released LNG will burn only at the evaporating edges of the pool. However, the most likely outcome from an LNG release event is formation of a cryogenic pool, and gradual evaporation without ignition. A pool fire will only start if an energetic ignition source is present. LNG pools are difficult to ignite. The cold vapours extinguish any flames rather than ignite unless the flame source is sufficiently hot. The conditional probability of a pool fire has a lower probability of occurrence than a pool evaporating.

In the unlikely event that a natural gas vapour cloud at concentrations within the flammability range formed and the vapour cloud was ignited, combustion would occur. Once the vapour cloud burned back to its source, the magnitude of the fire would depend on the rate of LNG release, which would continue to fuel the fire until the source was eliminated or the fire extinguished [52].

Explosions of LNG are unlikely to occur, except in poorly ventilated, confined conditions, when natural gas vapours are present within the range of flammability and are exposed to an ignition source. Confinement in an enclosed structure can allow for the accumulation of flammable vapours [52].

The magnitude of effects associated with an explosion or natural gas-fuelled fire depends on factors such as the volume of LNG for combustion and the duration of availability, atmospheric conditions dictating the movement and dispersion of the vapour cloud (particularly wind speed and direction, temperature, humidity, and precipitation), proximity of the incident to personnel and sensitive resources, and the effectiveness of emergency response activities [52].

5.5.2 Condensate Properties

Condensates are composed mainly of alkanes (saturated hydrocarbons, such as butane, pentane, and hexane) and are low in Polycyclic Aromatic Hydrocarbons (PAH) that are typically found in crude oils.

Condensates have a low solubility in-water and are highly volatile. They also have a low density and, if spilled, would typically float on the sea surface, and begin to evaporate quickly [33].

The main hazards associated with condensate spills are linked to explosions, fire, and exposure to vapours.

5.5.3 Fuel Properties

Fuel capacity for an LNG carrier is typically between 5,000 and 7,000 m³. For the size of NGL product vessels calling at the marine terminal, their fuel capacity will be less.

In 2006, the IMO adopted an amendment to *MARPOL Annex 1* to include the new *Regulation 12A – Oil fuel tank protection* [56]. The Regulation applies to all ships delivered on or after 1 August 2010. It includes requirements for the protected location of fuel tanks and performance standards for accidental oil fuel outflow. A maximum capacity limit of 2,500 m³ per oil fuel tank is included in the Regulation [57].

Under the new IMO rules, all fuel tanks must be at least 760 mm from the ships side on both LNG carriers and NGL product vessels. The LNG carrier will have tanks at least 1,000 mm from the ships side but generally 2,000 mm or more. In the event of a grounding the distance from the outer hull to fuel tank significantly reduces the chance of a fuel tank being breached.

Fuel is generally drawn down on a tank-by-tank basis so that when bunkering, existing fuel is not mixed with the new fuel. This means it is possible for some fuel tanks on board an LNG carrier or NGL product vessel to be full. Because fuel tanks are never full, the largest credible fuel release is approximately 95% of a full tank, or 2,375 m³ of fuel.

LNG carriers and NGL product vessels visiting the marine terminal will use a variety of fuels. LNG carriers may use:

- Boil off gas or LNG heated for this purpose
- Very low sulphur fuel oil (VLSFO)
- Marine diesel oil (MDO)
- Marine gas oil (MGO)

NGL product vessels will use the same fuels, but not BOG.

Under new IMO rules it is unlikely that LNG carriers or NGL product vessels will carry heavy fuel oil (HFO) [58]. Some ships may still use HFO and remain compliant with IMO requirements by installing exhaust gas cleaning systems, also known as "scrubbers" [58]. Some NGL product vessels may be fitted with these systems but given that VLSFO is now readily available, ships likely will not be using HFO by the time the Project starts operations.

5.5.4 Release at the Marine Terminal

5.5.4.1 Credible LNG Release

All LNG export facilities that have received an EA certificate have estimated the worst-case credible scenario, while loading an LNG carrier at the marine terminal, to be the rupture of the main loading line or a loading arm. The Project's nominal FLNG to LNG loading rate is 12,000 m³ / hour [59].

Pacific Northwest LNG assumed the worst-case credible scenario was a full rupture of the loading line (i.e., with a diameter of 500 mm) at the marine terminal with a delayed shutdown of 4 minutes (Pacific Northwest LNG noted the emergency shutdown valves for the marine terminal had a response time of 30 seconds or less). This resulted in a spill of 1,000 m³ with a lower flammability limit (LFL) of 1,850 m [52].

Pacific Northwest LNG later lowered the marine terminal loading rate to 12,000 m³ / hour. Under this lower loading rate, Pacific Northwest LNG stated the maximum spill size would be 800 m³.

Woodfibre LNG and Pacific Northwest LNG and estimated the maximum release from the rupture of a loading arm to be 33 m³ [60] and 83 m³ [61] respectively. The loading arms on the Project FLNGs will have quick connect disconnect couplers (QCDC) and emergency shutdown (ESD) valves. The shutdown of an individual loading arm would be completed in less time than shutdown of the main loading line.

Due to the design of the FLNGs, the LNG carriers and NGL product vessels, a release of LNG or condensate does not necessarily spill into the marine environment. Sumps under loading arms, loading lines and manifolds contain LNG or condensate in the event of a release.

The preliminary quantitative risk assessment (QRA) for the Project (see Section 5.6) assessed a loading arm leak frequency to be 2.0E-04 per year and a total loading line rupture frequency of 1.0E-05 per year.

Until Project-specific data is provided during front-end engineering design (FEED), it is assumed the worst-case credible LNG release at the marine terminal would be in the magnitude of 800 m³ with an LFL of up to 1,850 m.

5.5.4.2 Credible Condensate Release

Loading rates for condensate will be developed during detailed project planning. Given the relatively small volumes of condensate to be shipped, the overall loading rates for condensate will be smaller than the loading rate for LNG. Condensate loading will be monitored closely. In the event of a release, emergency shutdown valves would be activated, likely limiting the volume of condensate released to less than has been estimated for full ruptures of LNG loading arms (i.e., likely less than the 33m³ to 83m³ range noted above).

5.5.5 Collision and Terminal Allision

LNG projects have assessed the risk of an LNG carrier or NGL product vessel colliding with the marine terminal. These studies concluded that, because vessels near the marine terminal will move slowly, assisted by tugs and under the guidance of pilots, an allision with the marine terminal is unlikely to occur and unlikely to result in the release of cargo.

The Project's marine terminal siting further mitigates this risk. The marine terminal is a long distance from the centre of Portland Canal and the route transited by large vessels. Wil Milit is in a natural indentation on Pearse Island between Tree Point and Stick Point. Vessels are unlikely to be transiting close to Pearse Island due to the navigation hazards north of Tree Point (which vessels passing the marine terminal to transit further north along Portland Canal encounter) and the turns required near Portland Point and Spit Point.

The route of passing vessels is parallel to the marine terminal. A passing vessel likely would not be travelling at a speed and angle to create a breach in the double hull of the FLNG or vessel at berth. If a vessel collides at a shallow angle the hull is less likely to be breached. The FLNG berthing fenders will also protect the FLNG hull. Past risk assessments have assumed impacts at very shallow angles (i.e., less than 22.5°) will not penetrate LNG carrier cargo tanks [45]. It is reasonable to assume this same assumption applies to impacts of FLNGs.

5.5.6 LNG Carrier Grounding

Despite several groundings and collisions involving LNG carriers there has not been a single incident of LNG being lost through a breach or failure of the cargo tanks. There have been a few major grounding incidents, but none caused loss of cargo [4] or the necessity to release cargo [32].

In the case of grounding LNG could be released if a cargo tank is breached. Research has suggested that penetration into a double-hulled must be approximately three metres (m) before a hole occurs in the inner hull [62]. Given there has not been a single incident of LNG being lost through a breach or failure of the cargo tanks, most LNG risk assessments agree the complete loss of more than one LNG carrier cargo tank is not credible.

Design LNG carriers range from approximately 140,000 m³ to of 217,000 m³ capacity. LNG carriers calling at the marine terminal are not forecast to exceed approximately 180,000 m³ capacity. LNG carriers to 180,000 m³ capacity will have 4 tanks each with a volume of approximately 43,000 m³ [55]. The LNG facility is being designed for LNG carriers up to 217,000 m³ capacity as a future provision. These LNG carriers will have 5 tanks each with a similar capacity of approximately 43,000 m³ [55] [52].

Fuel may also be released in a grounding event. It is unlikely more than one tank would be breached given the new standards for fuel tank placement and construction.

The worst-case credible consequences from a grounding involving an LNG carrier grounding are approximately 43,000 m³ of LNG or up to 2,375 m³ of fuel being released. Given the different locations of cargo tanks and fuel tanks on most modern LNG carriers it is unlikely both fuel and LNG would be released in the same event.

Other projects have estimated the distance to the LFL could reach 1,700 m under credible scenarios [52]. This value agrees with another research report that suggests that for nominal accidental spills, the resulting hazard ranges could extend up to 1,700 m [62].

5.5.7 NGL Product Vessel Grounding

Condensate is forecast to be shipped in parcels of approximately 10,000 m³ (i.e., 5,000 m³ per FLNG). NGL product vessels with capacities to approximately 25,000 dwt generally have relatively more tanks compared to larger bulk liquid carriers. The smaller tanks sizes mean it is possible more than one tank could be breached. The smaller tank sizes also mean the volume of condensate that would be released in the event of a grounding is likely to be less than the total volume being shipped.

Fuel may also be released in a grounding event (see Section 3.5.3). It is unlikely more than one tank would be breached given the new standards for fuel tank placement and construction.

The worst-case credible consequences from a grounding involving an NGL product vessel grounding are less than 10,000 m³ of condensate or up to 2,375 m³ of fuel being released.

5.5.8 LNG Carrier Collision

The consequences from a worst-case credible collision involving an LNG carrier are assumed to be the same as grounding with approximately 43,000 m³ of LNG being released from no more than one cargo tank or up to 2,375 m³ of fuel being released. Other projects have estimated the distance to the LFL could reach 1,700 m [52]. This value agrees with another research report that suggests that for nominal accidental spills, the resulting hazard ranges could extend up to 1,700 m [62].

For an LNG carrier cargo tank to be breached, the vessel colliding with the LNG carrier would need to be travelling at a speed and angle where the other vessel would puncture the LNG carrier double hull with sufficient energy to breach an inner cargo tank. The velocity to breach an LNG cargo tank in a 90 deg collision with a large vessel is estimated to be 6 to 7 kns [62]. Collisions at shallower angles would need higher speeds to penetrate an LNG cargo tank [62]. Risk assessments have assumed that the effect from very shallow angles (less than 22.5 degrees) will not penetrate the cargo tank [45].

At the angles required to cause a breach in an LNG cargo tank, the bow of the colliding vessel is likely to be damaged, but it is unlikely the colliding vessel's cargo holds / tanks or fuel will be affected. It is unlikely both the LNG carrier and vessel colliding would both have a loss of cargo.

5.5.9 NGL Product Vessel Collision

The consequences from a worst-case credible collision involving an NGL product carrier are assumed to be the same as grounding with less than 10,000 m³ of condensate being released from more than one tank or up to 2,375 m³ of fuel being released.

For an NGL product vessel cargo tank to be breached, the vessel colliding with the NGL product carrier will need to be travelling at a speed and angle where the other vessel will puncture the NGL product carrier double hull with sufficient energy to breach an inner cargo tank. The same principles described above for LNG carriers would apply to NGL product vessels involved in a collision.

5.6 Terminal QRA

The Project has completed a preliminary QRA for the natural gas liquefaction facility and marine terminal [63]. Further risk analysis will be completed during detailed project planning. The QRA completed for the terminal estimates individual risk. Individual risk contours include all scenarios considered. The variables considered in creating the contours include:

- Leak frequency
- Weather (wind speed and direction, temperature)
- Congested area locations
- Ignition location
- Ignition frequency

The risk tolerances in the QRA are based upon *CSA Z276-18 Liquefied natural gas (LNG) - Production, storage, and handling*² [65]. The preliminary QRA concluded: "the overall societal risk at the Site does not exceed intolerable risk based upon implementation of appropriate mitigations for loading scenarios.

² The QRA was completed before the release of *CSA Z276-22 Liquefied natural gas (LNG) - Production, storage, and handling* [64]

Loading cases represent approximately 40% of the site risk in aggregate, primarily due to the frequency of loading operations.”

5.7 Public Safety

Collisions and groundings are the only two credible scenarios that could lead to a release of cargo over a short period. These four conditions would need to be present for a community along the marine route to encounter natural gas above the LFL concentrations:

- A large amount of LNG would need to be released in a short amount of time
- An LNG carrier would need to be near the community
- A natural gas cloud could not meet an ignition source before reaching the community
- Winds would likely need to be still or moving slowly towards the community

Sandia National Laboratories (Sandia) completed two investigations into releases from LNG carriers [55], [62]. The reports examine accidental and intentional releases from LNG carriers nearshore (i.e., in more controlled environments) and offshore. For accidental releases Sandia concluded [62]:

- Accidental LNG cargo tank damage scenarios exist that could cause an effective breach area of 0.5 to 1.5 m²
- Due to existing design and equipment requirements for LNG carriers and implementing navigational safety measures such as traffic management schemes and safety zones, the risk from accidents is generally low
- The most significant impacts to public safety and property from an accidental spill exist within approximately 250 m of a spill, with lower impacts at distances beyond approximately 750 m from a spill
- Under a stable atmosphere, with low wind speeds and without the presence of an ignition source, the LNG spill vapour dispersion from an accidental spill might conservatively be approximately 1,500 to 1,700 m. The actual hazard distances will depend on breach and spill size, site-specific conditions, and environmental conditions

The Project’s siting and marine route are important risk mitigations. The Project’s marine route and Site are not located close to any communities. These distances to communities from the marine route are provided in the *Marine Route Report* [1]:

- Village of Masset, Haida Gwaii – 30.0 km
- City of Prince Rupert and District of Port Edward – 20.0 km
- Lax Kw’alaams – 9.5 km
- Village of Gingolx – 10.5 km
- Metlakatla – 12.0 km

Communities are not in areas with the highest collision or grounding hazards (see Section 5.6). There are a few seasonal harvest sites along Portland Inlet, but these are not occupied all the time and are not in the areas with the highest collision or grounding hazards.

Near the marine terminal, the navigable waterway is over 2.5 km wide meaning large passing vessels should always be at least 500 m from the marine terminal, likely further.

Risks to the public were estimated for LNG Canada and Pacific Northwest LNG. The risks to the public from both projects was low, without considering communities are not being near the highest collision or grounding hazards [52] [55]. Given the Project’s remote marine route and LNG facility location, Project circumstances do not require further risk assessment or vapour cloud modelling along the marine route.

For the terminal, further risk assessments will be completed as part of FEED.

References

- [1] Westmar Advisors Inc., "Marine Route," 1220197_P01_22_RPT_0001, 2023.
- [2] Westmar Advisors Inc., "Vessel Specifications," 1220197-P01-24-RPT-0001, 2023.
- [3] International Group of Liquefied Natural Gas Importers, "GIIGNL Annual Report - 2022," GIIGNL, Annual Report 3 ed., 2022. Accessed: Aug. 30, 2022. [Online]. Available: https://giignl.org/wp-content/uploads/2022/05/GIIGNL2022_Annual_Report_May24.pdf
- [4] International Group of Liquefied Natural Gas Importers, "LNG Information Paper #3." Accessed: Dec. 02, 2022. [Online]. Available: https://giignl.org/wp-content/uploads/2021/10/giignl2019_infopapers3.pdf
- [5] Lloyd's List Intelligence, "Maritime Safety 2012-2021 - A decade of progress." Accessed: Dec. 14, 2022. [Online]. Available: https://www.isesassociation.com/wp-content/uploads/2021/12/LLI-DNV_Safety_Report_web.pdf
- [6] International Maritime Organization, "Brief History of IMO." Accessed: Dec. 16, 2022. [Online]. Available: <https://www.imo.org/en/About/HistoryOfIMO/Pages/Default.aspx>
- [7] Del Norske Veritas, "Navigating new safety challenges after a decade of progress," DNV GL. Accessed: Dec. 14, 2022. [Online]. Available: <https://www.dnv.com/expert-story/maritime-impact/Navigating-new-safety-challenges-after-a-decade-of-progress.html>
- [8] Transport Canada, "Permanent Mission of Canada to the International Maritime Organization." Accessed: Dec. 16, 2022. [Online]. Available: <https://tc.canada.ca/en/marine-transportation/canada-s-international-maritime-presence/permanent-mission-canada-international-maritime-organization>
- [9] International Association of Classification Societies, "Classification societies – their key role." Accessed: Dec. 16, 2022. [Online]. Available: <https://iacs.org.uk/media/8875/classification-societies-key-role.pdf>
- [10] Transport Canada, "Oceans Protection Plan," AE 15144968. Accessed: Dec. 16, 2022. [Online]. Available: <https://tc.canada.ca/en/initiatives/oceans-protection-plan>
- [11] Transport Canada, "The Government of Canada invests in marine emergency preparedness, response and partnerships as part of the next phase of the Oceans Protection Plan." Accessed: Jan. 22, 2023. [Online]. Available: <https://www.newswire.ca/news-releases/the-government-of-canada-invests-in-marine-emergency-preparedness-response-and-partnerships-as-part-of-the-next-phase-of-the-oceans-protection-plan-892640990.html>
- [12] Government of Canada, "Oceans Protection Plan Accomplishments - Pacific Region." Accessed: Dec. 15, 2022. [Online]. Available: <https://tc.canada.ca/en/initiatives/oceans-protection-plan/improving-marine-safety-through-oceans-protection-plan>
- [13] Government of Canada, "Oceans Protection Plan - Increasing Emergency Tow Capacity." Feb. 2018. Accessed: Dec. 15, 2022. [Online]. Available: <https://tc.canada.ca/en/initiatives/oceans-protection-plan/improving-marine-safety-through-oceans-protection-plan>
- [14] C. C. Guard, "Government of Canada extends contract for marine emergency towing vessels on the West Coast." Accessed: Jan. 03, 2023. [Online]. Available: <https://www.newswire.ca/news-releases/government-of-canada-extends-contract-for-marine-emergency-towing-vessels-on-the-west-coast-849438488.html>

- [15] Government of Canada, "Oceans Protection Plan - Marine Weather Information Services", Accessed: Dec. 15, 2022. [Online]. Available: <https://tc.canada.ca/en/initiatives/oceans-protection-plan/improving-marine-safety-through-oceans-protection-plan>
- [16] Prime Minister's Office, "Delivering clean oceans and healthy coasts with an expanded Oceans Protection Plan." Accessed: Jan. 22, 2023. [Online]. Available: <https://www.newswire.ca/news-releases/delivering-clean-oceans-and-healthy-coasts-with-an-expanded-oceans-protection-plan-859647678.html>
- [17] Government of Canada, "Oceans Protection Plan - The Reconciliation Framework Agreement for Bioregional Oceans Management and Protection", Accessed: Dec. 15, 2022. [Online]. Available: <https://tc.canada.ca/en/initiatives/oceans-protection-plan/improving-marine-safety-through-oceans-protection-plan>
- [18] Government of Canada, "Oceans Protection Plan - Hazardous and Noxious Substances." Feb. 2018. Accessed: Dec. 15, 2022. [Online]. Available: <https://tc.canada.ca/en/initiatives/oceans-protection-plan/improving-marine-safety-through-oceans-protection-plan>
- [19] Prince Rupert Port Authority, "Making a Safe Port Safer." Prince Rupert Port Authority, 2021. Accessed: Jun. 12, 2022. [Online]. Available: <https://www.rupertport.com/wp-content/uploads/2020/12/PRPA-Marine-Safety-MAKING-A-SAFE-PORT-SAFER-Brochure-Dec-2020-03.pdf>
- [20] Lloyd's List Intelligence, "Shipping and maritime intelligence," Seasearcher. Accessed: Sep. 28, 2022. [Online]. Available: <https://www.seasearcher.com/vessel/12930153/overview>
- [21] Lloyd's List Intelligence, "How detailed casualty data helps keep world trade moving." Accessed: Dec. 13, 2022. [Online]. Available: <https://www.lloydslistintelligence.com/knowledge-hub/data-storytelling/maritime-casualty-data-world-trade-moving>
- [22] *SOR/85-514 | Shipping Casualties Reporting Regulations*. CanLII. Accessed: Jul. 26, 2023. [Online]. Available: <https://www.canlii.org/en/ca/laws/regu/sor-85-514/93490/sor-85-514.html>
- [23] *SC 2001, c 26 | Canada Shipping Act, 2001*. CanLII. Accessed: Jul. 26, 2023. [Online]. Available: <https://www.canlii.org/en/ca/laws/stat/sc-2001-c-26/160998/sc-2001-c-26.html>
- [24] *SOR/2014-37 | Transportation Safety Board Regulations*. CanLII. Accessed: Jul. 26, 2023. [Online]. Available: <https://www.canlii.org/en/ca/laws/regu/sor-2014-37/145130/sor-2014-37.html>
- [25] Natural Resources Canada, "Canadian LNG Projects." Accessed: Dec. 02, 2022. [Online]. Available: <https://www.nrcan.gc.ca/energy/energy-sources-distribution/natural-gas/canadian-lng-projects/5683>
- [26] Saint John LNG, "Our History," Saint John LNG. Accessed: Jan. 25, 2023. [Online]. Available: <https://www.saintjohnlng.com/our-history>
- [27] Grace Kennedy, "FortisBC LNG site exports first shipment of gas to China," *Saanich News*, Nov. 22, 2017. Accessed: Jan. 25, 2023. [Online]. Available: <https://www.saanichnews.com/business/fortisbc-lng-site-exports-first-shipment-of-gas-to-china/>
- [28] Fortis BC, "FortisBC secures first export contract for Tilbury LNG facility," www.fortisbc.com. Accessed: Dec. 15, 2022. [Online]. Available: <https://www.fortisbc.com/news-events/media-centre-details/2019/07/16/fortisbc-secures-first-export-contract-for-tilbury-lng-facility>
- [29] Shell Global, "LNG Canada." Accessed: Dec. 15, 2022. [Online]. Available: <https://www.shell.com/about-us/major-projects/lng-canada.html>
- [30] Enbridge Inc., "Woodfibre LNG Project." Accessed: Dec. 15, 2022. [Online]. Available: <https://www.enbridge.com/projects-and-infrastructure/projects/woodfibre-lng>

- [31] Enbridge Inc., "Volume 8A: Overview and General Information - Marine Transportation," vol. 8, p. 152, 2010.
- [32] Fanch Cabioc'h *et al.*, "Accidents on Vessels Transporting Liquid Gases and the Responders' Concerns: The Galerne Project," in *Proceedings of the Thirty-second AMOP Technical Seminar on Environmental Contamination and Response*, Ottawa, ON: Environment Canada, 2009. Accessed: Dec. 02, 2022. [Online]. Available: <https://docslib.org/doc/12650855/accidents-on-vessels-transporting-liquid-gases-and-responderso-concerns-the-galerie-project>
- [33] International Tanker Owners Pollution Federation Limited, "Condensates - Promoting Effective Spill Response," ITOPF. Accessed: Aug. 30, 2022. [Online]. Available: <https://www.itopf.org/knowledge-resources/documents-guides/condensates/>
- [34] Maritime Safety Administration of P.R. China, "Report on the Investigation of the Collision between M.T. SANCHI and M.V. CF CRYSTAL in East China Sea on 6 January 2018," May 2018.
- [35] Oil Companies International Marine Forum, "OCIMF Safety Bulletin: Sanchi and CF Crystal Collision Incident." Accessed: Dec. 06, 2022. [Online]. Available: <https://www.ocimf.org/document-library/56-ocimf-safety-bulletin-sanchii-and-cf-crystal-collision-incident/file>
- [36] Transportation Safety Board of Canada, "Policy on Occurrence Classification." Accessed: Aug. 04, 2023. [Online]. Available: <https://www.tsb.gc.ca/eng/lois-acts/evenements-occurrences.html>
- [37] Clear Seas Centre for Responsible Marine Shipping, "Maritime Commercial Incidents and Accidents," Clear Seas. Accessed: Jul. 29, 2022. [Online]. Available: https://clearseas.org/en/research_project/maritime-commercial-incidents-and-accidents/
- [38] National Association of State Fire Marshals, "LIQUEFIED NATURAL GAS: An Overview of the LNG Industry for Fire Marshals and Emergency Responders." Accessed: Dec. 21, 2022. [Online]. Available: https://primis.phmsa.dot.gov/comm/publications/lng_for_fire_marshalls_06-2005.pdf
- [39] Westmar Advisors Inc., "Marine Traffic," 1220197-P01-21-RPT-0001, 2023.
- [40] Dillon Consulting, "Marine Navigational and Anchorage Areas Risk Assessment Report," Prince Rupert Port Authority. Accessed: Aug. 15, 2022. [Online]. Available: <https://www.rupertport.com/wp-content/uploads/2021/02/Marine-Navigational-and-Anchorage-Areas-Risk-Assessment-Report-Final-3rd-Party-Memo-Extracted.pdf>
- [41] Greenwood Marine Solutions, "Prince Rupert Ship Routing Advisory Study." Prince Rupert Port Authority, Sep. 30, 2015. Accessed: Aug. 13, 2022. [Online]. Available: <https://greenwoodmaritime.com/portfolio-items/ship-routing-advisory-study/>
- [42] Del Norske Veritas, "Prince Rupert Marine Risk Assessment." Prince Rupert Port Authority, Feb. 29, 2012. Accessed: May 29, 2022. [Online]. Available: https://archives.bape.gouv.qc.ca/sections/mandats/installation_gaz_naturel-becancour/documents/DB5.1.pdf
- [43] Prince Rupert Port Authority, "Navigational Risk Assessment." Accessed: Jun. 29, 2022. [Online]. Available: <https://www.rupertport.com/wp-content/uploads/2020/12/PRPA-Marine-Safety-NAVIGATIONAL-RISK-ASSESSMENTS-Brochure-Dec-2020-03.pdf>
- [44] Transport Canada, "TERMPOL Review Process Report on the Pacific Northwest LNG Project." Apr. 2017. Accessed: Jul. 29, 2022. [Online]. Available: <https://www.iaac-aeic.gc.ca/050/evaluations/proj/80032?culture=en-CA>

- [45] Transport Canada, "TERMPOL Review Process Report on the KITIMAT LNG Project," 1977. Accessed: Aug. 10, 2022. [Online]. Available: <https://tc.canada.ca/en/marine-transportation/marine-safety/tp-15385-term-pol-review-process-kitimat-lng-project>
- [46] Transport Canada, "TERMPOL Review Process Report on the LNG CANADA Project," Jul. 2022. Accessed: Jul. 28, 2022. [Online]. Available: <https://publications.gc.ca/site/fra/9.808172/publication.html>
- [47] Health and Safety Executive, "Risk management: Expert guidance - ALARP at a glance." Accessed: Dec. 04, 2022. [Online]. Available: <https://www.hse.gov.uk/managing/theory/alarpglance.htm>
- [48] Public Services and Procurement Canada, "Pilotage Risk Management Methodology (PRMM)." Accessed: Dec. 04, 2022. [Online]. Available: <https://publications.gc.ca/site/eng/9.693193/publication.html>
- [49] Canadian Coast Guard, "New equipment for Canadian Coast Guard will help clean up oil spills." Accessed: Jan. 25, 2023. [Online]. Available: <https://www.newswire.ca/news-releases/new-equipment-for-canadian-coast-guard-will-help-clean-up-oil-spills-840377862.html>
- [50] CRC, c 1416 | *Collision Regulations*. CanLII, 2007. Accessed: Jul. 26, 2023. [Online]. Available: <https://www.canlii.org/en/ca/laws/regu/crc-c-1416/213743/crc-c-1416.html>
- [51] Fisheries and Oceans Canada, "Navigational Warnings and Notices." Accessed: Jan. 25, 2023. [Online]. Available: <https://e-navigation.canada.ca/topics/notices/index-en>
- [52] Stantec Consulting Ltd., "Environmental Impact Statement and Environmental Assessment Certificate Application Section 22: Accidents or Malfunctions." Accessed: Dec. 07, 2022. [Online]. Available: <https://ceaa-acee.gc.ca/050/documents/p80032/98696E.pdf>
- [53] Michelle Michot Foss, "An overview on liquefied natural gas (LNG), its properties, the LNG industry, and safety considerations," Jun. 2012. Accessed: Dec. 08, 2022. [Online]. Available: <https://www.beg.utexas.edu/files/energyecon/global-gas-and-lng/INTRODUCTION%20TO%20LNG%20Update%202012.pdf>
- [54] Coffey Natural Systems, "Environmental Impact Statement PNG LNG Project - LNG Safety." Accessed: Dec. 06, 2022. [Online]. Available: https://pnglng.com/media/PNG-LNG-Media/Files/Environment/EIS/eis_attachment01.pdf
- [55] Marion Hightower, Anay Luketa-Hanlin, and Stephen Attaway, "Breach and safety analysis of spills over water from large liquefied natural gas carriers.," Sandia National Laboratories, SAND2008-3153, 983670, May 2008. doi: 10.2172/983670.
- [56] International Maritime Organization, "International Convention for the Prevention of Pollution from Ships (MARPOL)," *Int. leg. mater.*, vol. 17, no. 3, p. 45, Nov. 1973, doi: 10.1017/S0020782900052013.
- [57] International Maritime Organization, "Oil fuel tank protection." Accessed: Dec. 20, 2022. [Online]. Available: <https://www.imo.org/en/OurWork/Environment/Pages/OilFuelTankProtection.aspx>
- [58] International Maritime Organization, "IMO2020 fuel oil sulphur limit - cleaner air, healthier planet." Accessed: Dec. 20, 2022. [Online]. Available: <https://www.imo.org/en/MediaCentre/HotTopics/Pages/Sulphur-2020.aspx>
- [59] Ksi Lisims LNG, "Ksi Lisims LNG Detailed Project Description," BC Environmental Assessment Office, 2022, p. 680. Accessed: Aug. 15, 2022. [Online]. Available: <https://www.projects.eao.gov.bc.ca/p/60edc23bc69c5e0023a12539/project-details>

- [60] Stantec Consulting Ltd., "Technical Memorandum - Section 22 Accidents or Malfunctions - Reference: Marine LNG Spill." Accessed: Dec. 20, 2022. [Online]. Available: <https://projects.eao.gov.bc.ca/p/588511ccaaecd9001b825db8/project-details>
- [61] Rhey Lee, Susan Guo, and Therese Baas, "Appendix 11-1: Preliminary QRA for Woodfibre LNG," Lloyd's Register Consulting, Oct. 2014.
- [62] Gerald Wellman *et al.*, "Guidance on risk analysis and safety implications of a large liquefied natural gas (LNG) spill over water.," SAND2004-6258, 882343, Dec. 2004. doi: 10.2172/882343.
- [63] Process Safety and Reliability Group and Western LNG, "Quantitative Risk Assessment (QRA) for the Western LNG Ksi Lisims LNG Project." Oct. 14, 2022.
- [64] Canadian Standards Association, "CSA Z276:22 - Liquefied natural gas (LNG) - Production, storage, and handling," CSA Group. Accessed: Nov. 20, 2022. [Online]. Available: <https://www.csagroup.org/store/product/2701470/>
- [65] Canadian Standards Association, "CSA Z276-18 Liquefied natural gas (LNG) - Production, storage, and handling." Jul. 2018. Accessed: Dec. 18, 2022. [Online]. Available: <https://www.csagroup.org/store/product/Z276-18/>

Appendix A

Clear Seas Data

DRAFT



Summary of Maritime Commercial Incidents and Accidents Along the Preferred Route

From Clearseas database of incidents from January 2009 to December 2018 (<https://experience.arcgis.com/experience/49bbdd14769646f69cc80cabcb5ac5d5>)

Map ID	Date	Vessel ID	Vessel Name	Vessel Type	Incident Type	Incident Description
1	March 1, 2018	26942	PALANCA MUSCAT	Crude Tanker (Incl Bitumen/Asphalt)	Risk of Incident	On 01 March 2018, the tanker "PALANCA MUSCAT" reported a fuel leak with the main engine and intentionally dropped anchor in McIntyre Bay, BC to have repairs conducted.
2	March 12, 2017	25874	CAPITAL C	Tug	Total Failure of any System	On 12 March 2017, the tug "CAPITAL C", while towing the loaded log barge "STRAITS WATER SKIDDER", reported a fouled propeller near Parry Passage, Langara Island, BC. The tug released the tow line to free up the propeller.
3	February 25, 2018	26945	SEA VENUS	Bulk Carrier	Total Failure of any System	On 25 February 2018, the bulk carrier "SEA VENUS" was proceeding at reduced speed due to machinery failure in Dixon Entrance, BC. The crew conducted repairs and the vessel continued on its voyage.
4	October 1, 2018	27385	SCARLET ROBIN	Bulk Carrier	Total Failure of any System	On 01 October 2018, the bulk carrier "SCARLET ROBIN" reported as disabled due to issues with the main engine caused by faulty injectors. The vessel drifted towards Dixon Entrance, BC while repairs were carried out by the crew.
5	October 5, 2016	10933	STRAITS WATER SKIDDER	Barge - General Cargo	Sustains Damage Render Unseaworthy/Unfit for Purpose	On 05 October 2016, the tug "CAPITAL C", with 4 people on board and a loaded barge "STRAITS WATER SKIDDER" in tow, reported that the barge was taking on water and consequently heeled near Naden Harbour, BC. The crew carried out temporary repairs and stabilized the barge with the assistance of a Royal Canadian Marine Search and Rescue vessel. The Canadian Coast Guard cutter "CAPE DAUPHIN" provided escort assistance to the tug to Masset Inlet, BC, and stood down. The tug continued its voyage and towed the barge to Port Clements, BC without any assistance.
6	January 1, 2017	26159	COSCO ANTWERP	Container Ship	Total Failure of any System	On 01 January 2017, the container ship "COSCO ANTWERP" reported a total failure of its main engine in Dixon Entrance, BC. The crew effected repairs to a fuel injector and the vessel continued to Vancouver, BC.
7	March 28, 2016	19495	NORTH ARM VICTOR	Tug	Total Failure of any System	On 28 March 2016, the tug "NORTH ARM VICTOR", with 5 people on board, reported the towing arrangement failed while towing the fuel barge "NORTH ARM GENESIS" in Dixon Entrance, BC. The barge was adrift while the crew attempted to re-secure it. The crew managed to re-attach the tow and continued to Prince Rupert, BC.
8	June 10, 2016	1053	SKEENA COAST	Tug	Total Failure of any System	On 10 June 2016, the tug "SKEENA COAST" reported as disabled due to a machinery failure in the Hecate Strait, BC. The crew made repairs and the vessel resumed its voyage.
9	April 26, 2018	27039	KAVO YERAKI	Bulk Carrier	Total Failure of any System	On 26 April 2018, the bulk carrier "KAVO YERAKI" was reported as disabled due to a machinery failure while transiting Dixon Entrance, BC. The crew conducted repairs and the vessel continued its voyage.
10	December 12, 2016	26120	JIANGMEN TRADER	Bulk Carrier	Total Failure of any System	On 12 December 2016, the bulk carrier "JIANGMEN TRADER" reported its main engine not operational in Dixon Entrance, BC. The crew conducted repairs and the vessel continued on its voyage.
11	September 1, 2015	22794	DISNEY WONDER	Passenger Only	Fire/Explosion	On 01 September 2015, the passenger vessel "DISNEY WONDER", with 3321 people on board, reported a fire in the engine exhaust casing in Brown Passage, BC. The fire team responded and controlled the fire with extinguishers. No injuries or pollution reported.
12	May 21, 2011	22666	PARAGON	Tug	Collision	On 21 May 2011, the US tug "PARAGON" was towing a barge through Dixon Entrance, B.C. The tug collided with anchored pleasure craft "DOUBLE DIP" fouling the anchor line, which had to be cut free from the tug.
13	January 6, 2016	25410	NEW JOURNEY	Bulk Carrier	Total Failure of any System	On 06 January 2016, the bulk carrier "NEW JOURNEY", with 20 people on board, reported a main engine failure on route to the Triple Island pilot station in Dixon Entrance, BC. The crew effected emergency repairs and proceeded to the pilot station. The vessel proceeded under the conduct of a pilot and with tug assist to anchorage #4 in Prince Rupert Harbour, BC.
14	July 9, 2017	26480	CSCL AFRICA	Container Ship	Total Failure of any System	On 09 July 2017, the container vessel "CSCL AFRICA", reported being disabled due to main engine control issues near Butterworth Rocks, BC. The crew members effected repairs and the vessel proceeded to Fairview Terminal, BC.
15	June 26, 2015	25043	MARE TRACER	General Cargo	Total Failure of any System	On 26 June 2015, the bulk carrier "MARE TRACER" reported disabled due to the loss of its main engine whilst approaching the Triple Island pilot station, Prince Rupert, BC. The vessel restarted its engines after embarking the pilot and headed to anchorage 04.
16	May 18, 2016	25637	ANDROMEDA	Bulk Carrier	Total Failure of any System	On 18 May 2016, the bulk carrier "ANDROMEDA", with 23 people on board and under the conduct of a pilot, reported a blackout due to generator fuel issues at Triple Island, BC. The vessel anchored at Anchorage 16, Prince Rupert, BC to have repairs carried out.
17	September 1, 2013	23551	CORIO BAY	General Cargo	Risk of Incident	On 01 September 2013, the pilot on board the "CORIO BAY" reported a near collision situation with the sports fishing vessel "SEA WOLF" while in the process of disembarking near Triple Islands, B.C. No injuries, damage or pollution reported.
18	June 30, 2013	23456	JINHE	Container Ship	Risk of Incident	On 30 June 2013 container ship "JINHE" and FV "VITAMIN SEA VI" experienced a close quarters situation near Triple Island, B.C. The "JINHE" had to stop engines to avoid a collision.
19	October 3, 2013	23786	ZHENG ZHI	Bulk Carrier	Risk of Incident	On 03 October 2013, the bulk carrier "ZHENG ZHI", under the conduct of a pilot, reported a close quarters situation with the F/V "WESTERN MIST" near Ruston Island, BC.
20	October 17, 2015	25255	AMARANTHA	Bulk Carrier	Sustains Damage Render Unseaworthy/Unfit for Purpose	On 17 October 2015, the bulk carrier "AMARANTHA", with 24 people on board reported ballast water ingress in a fuel tank through a crack while at Anchorage No. 23, Prince Rupert, BC. Repairs were carried out at anchorage with the assistance of shore contractors and the vessel resumed its voyage.
21	February 17, 2018	26933	DIAMOND QUEEN	Bulk Carrier	Risk of Incident	On 17 February 2018, the bulk carrier "DIAMOND QUEEN" reported as dragging anchor at anchorage #20, Prince Rupert, BC. The vessel was relocated to anchorage #8 Prince Rupert, BC under the conduct of a pilot.
22	March 13, 2013	23325	BLUE HORIZON	General Cargo	Risk of Incident	On 13 March 2013, the freighter "BLUE HORIZON" with a pilot on board, reported a close quarters situation with the f/v "VITAMIN SEA IV" near Rachel Islands, Chatham Sound, B.C. The freighter altered course to STBD to avoid the collision.
23	November 4, 2016	25982	ATLANTIC TULUM	Bulk Carrier	Sustains Damage Render Unseaworthy/Unfit for Purpose	On 04 November 2016, the bulk carrier "ATLANTIC TULUM" lost its port anchor while anchored outside of Prince Rupert, BC. The vessel re-anchored using starboard anchor under the conduct of a pilot.
24	March 27, 2010	22243	ZB335	Barge - General Cargo	Fire/Explosion	On 27 March 2010, the tug "SANDRA FOSS" was South bound towing the barge "ZB335". In the vicinity of Rachel Islands, Chatham Sound B.C., a fire broke out on the barge. The CG Cutter "POINT HENRY" responded. The fire was extinguished.
25	April 24, 2009	21921	UNKN SABRE RAMP BARGE	Barge - General Cargo	Sank	On 24 April 2009, the tug "SABRE" was towing a ramp barge in Duncan Bay, Chatham Sound B.C. The ramp barge grounded and was taking on water. The salvage tug "CASTLE LAKE" was on scene to refloat the barge at high water.
26	January 6, 2017	8561	T.L. SHARPE	Barge - Work/Construction/Salvage/Accommodation	Risk of Incident	On 06 January 2017, the barge "T.L. SHARPE", with no one on board, reported broken free and at a risk of grounding near Dodge Cove, Prince Rupert, BC. The tug "SMIT STAR", with the assistance of the Fraser River Pile & Dredge (GP) Inc. vessels, retrieved the barge and secured it at Fairview Terminal, Prince Rupert, BC. No pollution or injuries reported.
27	May 24, 2015	3197	FRASER WARRIOR	N/A	Total Failure of any System	On 24 May 2015, the tug "FRASER WARRIOR", with 2 people on board, girded and nearly capsized when the jog steering malfunctioned and the barge it was towing overtook it while the vessels were approaching the dock. Water was shipped on deck and the tug's propeller was fouled by a rope during the manoeuvre.
28	November 14, 2009	20083	SWIFT FORTUNE	Bulk Carrier	Total Failure of any System	On 14 November 2009 bulk carrier "SWIFT-FORTUNE" dragged and lost port anchor during strong winds at anchorage alpha in Prince Rupert harbour.
29	February 27, 2013	23317	FANTASY STAR	Bulk Carrier	Risk of Incident	On 27 February 2013, the bulk carrier "FANTASY STAR" reported dragging anchor at anchorage 7, Prince Rupert, B.C. and in danger of running aground. Vessel was repositioned to anchorage 7.
30	September 18, 2013	21083	NORTHERN ADVENTURE	Passenger - Cargo	Total Failure of any System	On 18 September 2013, the PV "NORTHERN ADVENTURE" reported failure of the port fast rescue boat davit while at anchorage #7, Prince Rupert, BC. Failure resulted in the boat with 2 POB dropping in the water. No injuries, pollution or damage reported.
31	November 10, 2015	25295	SARI INDAH	Bulk Carrier	Risk of Incident	On 10 November 2015, the bulk carrier "SARI INDAH" reported dragging anchor at Anchorage 7, Prince Rupert, BC and in danger of running aground. The vessel was repositioned by a pilot at Anchorage 4 with tug assistance.
32	November 4, 2016	25986	TAMPA BAY	Bulk Carrier	Risk of Incident	On 04 November 2016, the bulk carrier "TAMPA BAY" reported to be dragging anchor in Prince Rupert Harbor, BC. The vessel was repositioned under the conduct of a pilot.
33	September 27, 2015	25237	SCOTIA RIVER	Tug	Total Failure of any System	On 27 September 2015, the tug "SCOTIA RIVER", with one person on board, reported as disabled at Dundas Island, BC. The vessel will remain at its dock awaiting a suitable tow to Prince Rupert, BC.
34	January 13, 2012	16837	TAKU	Passenger/Vehicle	Total Failure of any System	On 13 January 2012, the Alaska State ferry "TAKU" experienced an oil leak in its steering quadrant while southbound in Chatham Sound, BC. The vessel returned to Ketchikan, Alaska.
35	April 16, 2016	25586	STAR LINDESNES	Bulk Carrier	Total Failure of any System	On 16 April 2016, the general cargo vessel "STAR LINDESNES", under the conduct of a pilot, reported a blackout due to main engine fuel issues in Portland Canal, BC. The crew carried out repairs and the vessel continued its voyage.

1 **ATTACHMENT E.4 VESSEL SPECIFICATION**



Ksi Lisims LNG
Navigation Safety Assessment

Vessel Specifications

11 October2023



Disclaimer

This report is not intended to stand alone without reference to the instructions given to Westmar by Ksi Lisims LNG, communications between Westmar and Ksi Lisims LNG, and any other reports, proposals or documents prepared by Westmar for Ksi Lisims LNG under the governing contract between Westmar and Ksi Lisims LNG. To understand the suggestions, recommendations and opinions expressed herein, reference must be made to all relevant documents and communications.

This report has been prepared only for the purposes that are set out in the governing contract between Westmar and Ksi Lisims LNG. The findings, recommendations, suggestions and or opinions expressed in this report are only applicable to the purposes for which the report is expressly provided, and then only to the extent that there has been no material alteration to or variation from the information provided or available to Westmar.

The information and opinions expressed in this report are for the sole use and benefit of Ksi Lisims LNG. No other party may use or rely upon the report or any portion thereof without Westmar's prior written consent, and such use shall be on terms and conditions as Westmar expressly approves. Ownership in and copyright for the contents of the report belong to Westmar. Any use which a third party makes of the report is the sole risk and responsibility of such third party. Westmar accepts no responsibility whatsoever for loss or damages suffered by any third party in relation to use of this report.

Company Details

Westmar Advisors Inc.
700 - 1901 Rosser Avenue
Burnaby, BC, V5C 6R6

T 604 770 4787

info@westmaradvisors.com

Table of Contents

Abbreviations	v
Preface	x
1 Introduction	1
1.1 LNG Carrier Fleet	1
1.2 NGL Product Vessel Fleet	2
2 Design Vessel Specifications	3
2.1 Classification	5
2.2 Ice Class	5
2.3 Ship Stability	5
2.4 Crewing and Certification Standards	5
2.5 Port State Control	6
2.6 Shipboard Navigation and Communication Equipment	6
2.7 LNG Carrier Design and Construction	7
2.7.1 Cargo Containment – Spherical-Type	8
2.7.2 Cargo Containment – Membrane-Type	8
2.7.3 Cargo Transfer Systems	10
2.7.4 Propulsion and Steering Systems	11
2.7.5 Auxiliary Power Systems	11
2.7.6 Main and Auxiliary Engine Cooling Systems	11
2.7.7 Manoeuvring Data	11
2.7.8 Safety Systems	12
2.8 NGL Product Vessel Design and Construction	13
2.8.1 Propulsion and Steering Systems	13
2.8.2 Manoeuvring Data	13
3 Vessel Acceptance Program	14
3.1 Compatibility Verification	14
3.2 Vetting Process	14
References	16

Appendices

- Appendix A SIGTTO LNG Officer Experience Matrix
- Appendix B SIRE Inspection Questionnaire - Chapters

List of Tables

Table 1 – Typical design LNG carrier and NGL product vessel parameters based on representative vessels.4

List of Figures

Figure 1 - Global LNG carrier fleet by cargo capacity (GIIGNL) [2].....	1
Figure 2 - Global LNG carrier fleet by age and cargo capacity.....	1
Figure 3 – LNG carrier growth by year (extract from the Interactive World LNG Dashboard © PE Maps / PE Media Network / Global Energy Infrastructure) [3]	2
Figure 4 – Spherical-type LNG carrier (left) and membrane-type LNG carrier (right).....	7
Figure 5 - Cross-section through a typical spherical carrier showing cargo containment arrangement (source Lloyd’s Register).....	8
Figure 6 – GTT No. 96 Invar primary and secondary barrier.....	9
Figure 7 – GTT MK III stainless-steel primary barrier, triplex secondary barrier.....	10
Figure 8 – Cutaway view of LNG carrier with GTT Mark III Tank, and details of GTT Mk III insulation (source GTT).....	10
Figure 9 – Representative LNG carrier turning distance at 12 kns speed.....	12

Abbreviations

Abbreviation	Description
°C	degrees Celsius
ABS	American Bureau of Shipping
ADCP	acoustic doppler current profiler
AIS	automatic identification system
AIS ATON	automatic identification system aid to navigation
AK	Alaska
ANSI	American National Standards Institute
ARI	average recurrence interval
ATON	aids to navigation
BC	British Columbia
BCCP	British Columbia Coast Pilots Ltd.
BCER	BC Energy Regulator
BNWAS	bridge navigational watch alarm system
BOG	boil off gas
BV	Bureau Veritas
CCG	Canadian Coast Guard
CHS	Canadian Hydrographic Services
CMB	continuous marine broadcast
CPAs	Compulsory Pilotage Areas
DAS	docking assist system
deg	degree
DFO	Fisheries and Oceans Canada
DNV	Det Norske Veritas
dwt	deadweight tonnage
EA	environmental assessment
ECCC	Environment and Climate Change Canada
ECDIS	electronic chart display and information system
EDG	emergency diesel generators
EEBD	Emergency Escape Breathing Device
EMSA	enhanced maritime situation awareness
ENC	electronic navigational chart
EOC	Emergency Operations Centre
EPIRB	emergency position-indicating radio beacon
ERS	emergency release system

Abbreviation	Description
ESD	emergency shut down
ETA	estimated time of arrival
EU	environmental unit
FEED	front-end engineering design
FFA	fire fighting appliances
FLNG	floating liquefaction, storage, and off-loading barge
FMBS	full mission bridge simulation
FMO	Federal Monitoring Officer
FSA	Formal Safety Assessment
FSRU	floating storage and regassification units
GMDSS	Global Maritime Distress, and Safety System
GNSS	Global Navigation Satellite System
GTT	Gaztransport and Technigaz
HFO	heavy fuel oil
HNS	hazardous and noxious substances
Hs	significant wave height
IACS	International Association of Classification Societies
IALA	International Association of Marine Aids to Navigation and Lighthouse Authorities
ICS	Incident Command System
IGC Code	<i>International Code for the Construction and Equipment of Ships Carrying Liquefied Gases in Bulk</i>
ILO	International Labour Organization
IMO	International Maritime Organization
ISGOTT	<i>International Safety Guide for Oil Tankers and Terminals</i>
ISM	International Safety Management
ISPS	<i>International Ship and Port Facility Security Code</i>
kHz	kilohertz
km	kilometre
kn	knot
LBP	length between perpendiculars
LFL	lower flammability limit
LLWLT	lower, low water, large tide
LNG	liquefied natural gas
LOA	length overall
LOS	level of service
LPG	liquefied petroleum gas
LR	Lloyd's Register

Abbreviation	Description
LSA	life-saving appliances
LSIR	location specific individual risk
LTA	line throwing appliance
m	metre
m	metres per second
m ²	square metres
m ³	cubic metres
m ³	cubic metres
m ³ / hour	cubic metres per hour
MARPOL	<i>International Convention for the Prevention of Pollution of Ships</i>
MCTS	Marine Communications and Traffic Services
MDO	marine diesel oil
MGO	marine gas oil
MOF	material off-loading facility
MOU	Memorandum of Understanding
MSI	Marine Safety Inspectors
MSOC	Marine Security Operations Centre
MTBE	methyl tertiary butyl ether
mtpa	million tonnes per annum
NASP	National Surveillance Aerial Program
NAVTEX	Narrow Band Direct Printing Telegraphy
NAVWARN	navigational warnings
NGL	natural gas liquid
NK	Nippon Kaiji Kyokai
NLG	Nisga'a Lisims Government
NLS	Noxious Liquid Substances
NOA	notice of arrival
North Coast	north coast of British Columbia
NOTMAR	Notices to Mariners
NRA	BCCP / PPA Navigational Risk Assessment
NSA	navigation safety assessment
NW	northwest
OCIMF	Oil Companies International Marine Forum
ODAS	ocean data acquisition system
OGAA	<i>Oil and Gas Activities Act</i>
OPP	Oceans Protection Plan

Abbreviation	Description
OPRC	<i>International Convention on Oil Pollution Preparedness, Response and Co-operation</i>
OSC	On-Scene Commander
P&I	protection and indemnity (insurance)
P&I	protection and indemnity
PAH	polycyclic aromatic hydrocarbons
PAIR	Pre-Arrival Information Reports
PIANC	World Association for Waterborne Transport Infrastructure
PMS	planned maintenance system
PORCP	National Places of Refuge Contingency Plan
PPA	Pacific Pilotage Authority
PPO	Pollution Prevention Officer
PPU	portable pilot units
PRPA	Prince Rupert Port Authority
PRPRCP	<i>Pacific Region Places of Refuge Contingency Plan</i>
PSC	Port State Control
QCDC	quick connect disconnect couplers
QRA	quantitative risk assessment
QRH	quick release hooks
QSCS	Quality System Certification Scheme
racon	radar beacon
RNC	raster navigational chart
RO	recognized organization (with respect to flag state affairs)
RO	response organization (with respect to spill response)
RT	radiotelephony
s	seconds
SAR	search and rescue
SIGTTO	Society of International Gas Tanker and Terminal Operators
SIRE	Ship Inspection Report Programme
SMPEP	Shipboard Marine Pollution Emergency Plan
SOLAS	<i>International Convention for the Safety of Life at Sea (SOLAS), 1974</i>
SOPEP	Shipboard Oil Pollution Emergency Plan
SOPF	Ship-source Oil Pollution Fund
SSL	ship-shore link
STCW	<i>International Convention on Training, Certification, and Watchkeeping for Seafarers</i>
SW	southwest
SWL	safe working load

Abbreviation	Description
t	metric tonne (equal to 1,000 kilograms)
TCMSS	Transport Canada Marine Safety and Security
TERMPOL	Technical Review Process of Marine Terminal Systems and Transshipment Sites
TOM	Terminal Operations Manual
Tp	peak wave period
TSB	Transportation Safety Board of Canada
UKC	underkeel clearance
US	United States
V-ATON	virtual aid to navigation
VDR	voyage data recorder
VHF	very high frequency
VLSFO	very low sulphur fuel oil
VTS	Vessel Traffic Services
WCMRC	Western Canada Marine Response Corporation

Preface

A Navigation Safety Assessment (NSA) is part of the Application. The NSA is an opportunity to review the Ksi Lisims LNG Project and determine whether additional resources (e.g., pilots), controls or infrastructure (e.g., navigational aids) are required and when they need to be in place. The NSA studies make-up Appendix E and findings inform Section 9 Malfunctions and Accidents and other sections (e.g., Section 7.11 Marine Use). Section 9.1.2 Planning provides a list and high-level description of the NSA studies. Additional navigation simulations will be completed before the start of operations and will be the subject of approval conditions.

1 Introduction

The *Vessel Specification Report* is part of the Navigation Safety Assessment (NSA) for Ksi Lisims LNG – Natural Gas Liquefaction and Marine Terminal Project (the Project). An overview of the Project, including the selected marine route to be used by liquefied natural gas (LNG) carriers and natural gas liquid (NGL) product vessels, is provided in the *Marine Route Report* [1].

This report describes the specifications for the LNG carriers and NGL product vessels forecast to call at the marine terminal (i.e., the design vessels). The design vessels are used worldwide and are not unique to the Project. This report reviews the existing world LNG carrier and NGL product vessel fleet, vessel regulatory requirements, and vessel safety features. The Project’s vessel acceptance program for LNG carriers and NGL product vessels is also described.

1.1 LNG Carrier Fleet

At the end of 2021, there were 700 LNG carriers worldwide, including floating storage and regassification units (FSRUs), floating liquefaction, storage, and offloading barges (FLNGs) and bunker vessels with a total capacity of 103 million m³[2]. 588 LNG carriers have a capacity over 50,000 m³ (see Figure 1).

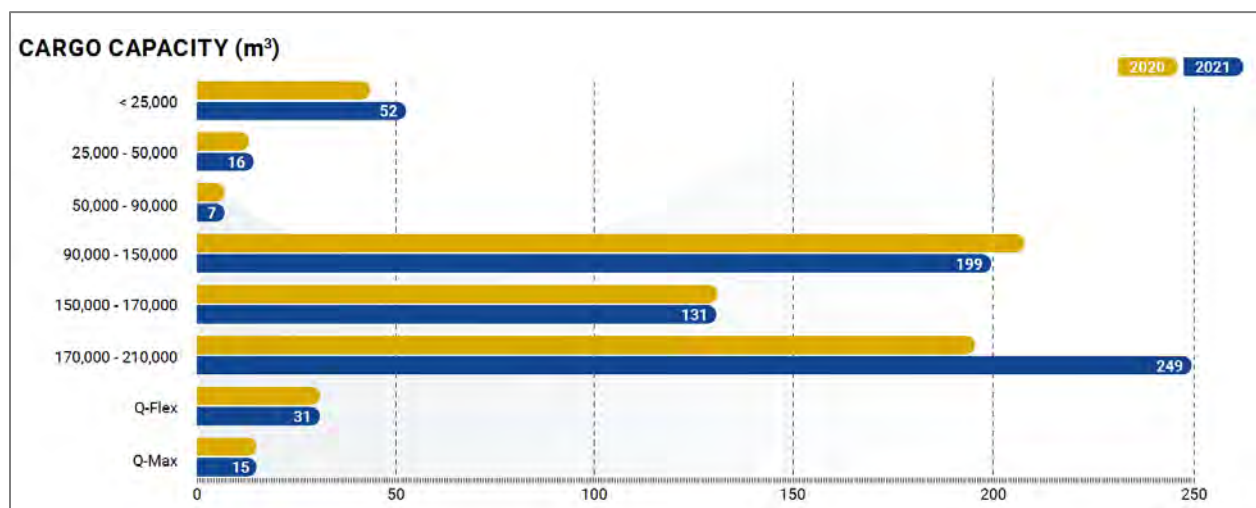

Figure 1 - Global LNG carrier fleet by cargo capacity (GIIGNL) [2]

Approximately 55% of the fleet is less than 10 years old (see Figure 2).

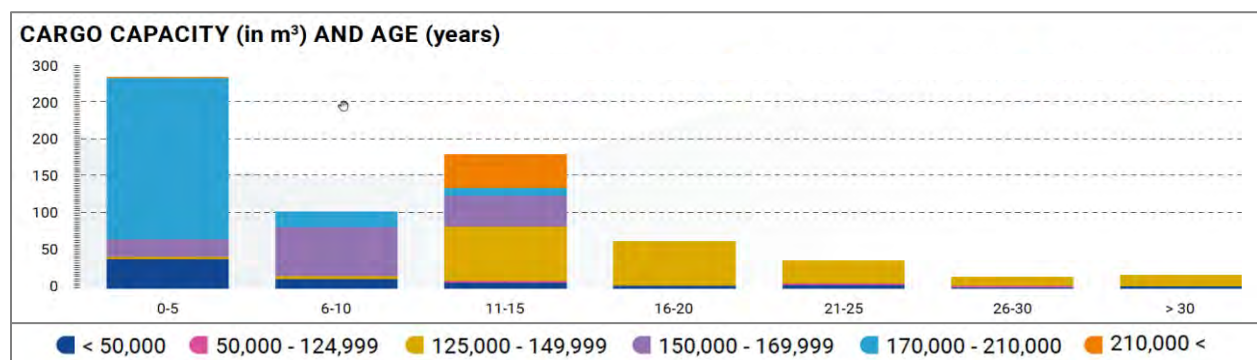

Figure 2 - Global LNG carrier fleet by age and cargo capacity

The LNG carrier fleet is forecast to continue growing with close to 300 new builds through 2027 (see Figure 3). The delivery of new LNG carriers is forecast to peak in 2025. Most of the forecast newbuilds are conventional LNG carriers [3].

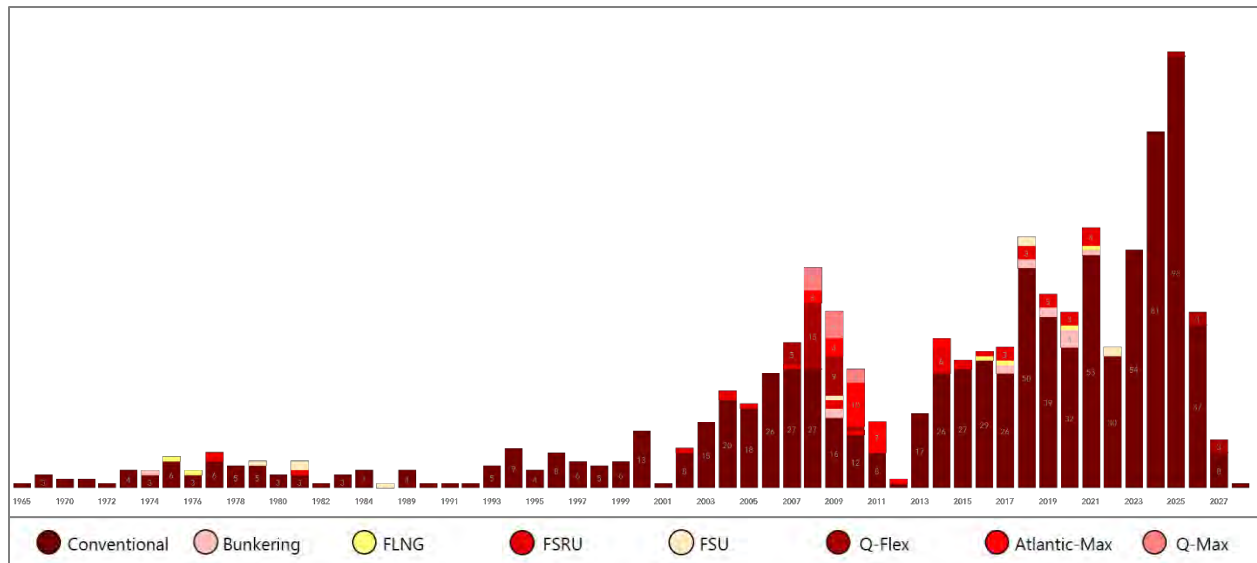

Figure 3 – LNG carrier growth by year (extract from the Interactive World LNG Dashboard © PE Maps / PE Media Network / Global Energy Infrastructure) [3]

1.2 NGL Product Vessel Fleet

There are over 4,000 active chemical and product vessels operating globally under the International Association of Classification Societies (IACS) classification. The average deadweight tonnage (dwt) of vessels in this group is 25,000 dwt. The group includes approximately:

- 2,985 smaller vessels under 10,000 dwt
- 1,224 vessels between 10,000 dwt and 20,000 dwt
- 294 vessels between 20,000 dwt and 30,000 dwt
- 524 vessels between 30,000 dwt and 40,000 dwt
- 755 vessels between 40,000 dwt and 50,000 dwt
- There are over 250 chemical vessels greater than 50,000 dwt

The chemical and product vessels in this group have an average age of 13 years.

2 Design Vessel Specifications

Commercial arrangements for transporting LNG and condensate will be established before the start of operations. The design LNG carriers and NGL product vessels selected for the NSA encompass the range of vessel sizes that may call at the marine terminal.

Design LNG carriers range from approximately 140,000 m³ to 217,000 m³ capacity. LNG carriers calling at the marine terminal are not forecast to exceed approximately 180,000 m³ capacity. The LNG facility is being designed for LNG carriers up to approximately 217,000 m³ capacity as a future provision. LNG carriers of this size are approximately 7% of the global LNG carrier fleet (see Figure 1) and most serve dedicated routes from the Middle East. Design NGL product vessels range from approximately 5,000 to 30,000 dwt capacity.

Parameters for the design LNG carriers and NGL product vessels are in Table 1. Parameters are from representative vessels in the global LNG carrier and NGL product vessel fleets. The Project does not have commercial agreements with the named vessels and the vessels are not forecast to call at the marine terminal.

The design LNG carriers are similar in size to container ships, cruise ships, and dry bulk ships calling at the Port of Prince Rupert. On September 21, 2022, the MSC Auriga became the largest container vessel to berth at the Port of Prince Rupert [4]. The MSC Auriga's parameters are in Table 1 for comparison.

Table 1 – Typical design LNG carrier and NGL product vessel parameters based on representative vessels

Parameter	Largest Design LNG carrier	Largest Forecast Design LNG Carrier	Small Design LNG carrier	Largest Design NGL Product Vessel	Smallest Design NGL Product Vessel	MSC Auriga
Vessel Name	Al Khuwair	Gail Bhuwan	Fuwairit	Savanna	Double Happiness	Auriga
Vessel Type	LNG carrier	LNG carrier	LNG carrier	Product Vessel	Product Vessel	Container
LNG Cargo Tank Type	Membrane	Membrane	Membrane	n/a	n/a	n/a
IMO Number	9360908	9877145	9256200	9798296	9655779	9857183
Year Built	2008	2021	2004	2017	2013	2020
Capacity [m ³]	213,101	176,570 ^a	138,262	29,785	5,519	14,300 (TEU)
dwt	116,338	98,882	74,067	24,202	4,999	134,500
Length Overall (LOA) [m]	315.06	297.91	278.8	155.06	90	366
Length Between Perpendiculars (LBP) [m]	302	291.5	266	149.8	85.83	347
Breadth [m]	50	47.9	42.6	36	15.8	48.2
Depth [m]	27.04	26.5	32.7	12.5	9.3	27.2
Draft (Fully Laden) [m]	12	11.5	11.35	6.8	6.53	16
Service Speed [kns]	19.5	19.5	20.2	12.5	14	n/a

^a LNG carriers calling at the marine terminal are not forecast to exceed approximately 180,000 m³ nominal capacity.

2.1 Classification

LNG carriers and NGL product vessels will be classified by a member of IACS. IACS is an organization of the leading classification societies, including Lloyd's Register (LR), Det Norske Veritas (DNV), American Bureau of Shipping (ABS), Bureau Veritas (BV), and Nippon Kaiji Kyokai (known as Class NK).

IACS establishes minimum technical standards and requirements that address issues related to maritime safety and environmental protection. IACS provides a Quality System Certification Scheme (QSCS) that IACS members comply with, committing to high professional standards. IACS is recognized as the principal technical advisor of the International Maritime Organization (IMO).

LNG carriers and NGL product vessels are constructed under the supervision of a classification society. A vessel built under the applicable rules of an IACS member society may be assigned a class designation by the society [5]. For vessels in service, the society carries out surveys to verify that the vessel remains in compliance with those rules [5].

2.2 Ice Class

The waters of the selected marine route and near the marine terminal are free of sea ice year-round and LNG carriers and NGL product vessels need not be classified for ice or have systems for dealing with prolonged periods of cold (i.e., arctic) weather. The weather at the marine terminal is typical of other marine terminals that LNG carriers and NGL product vessels frequently call at in Asia and Europe.

LNG carriers and NGL product vessels may be affected by ice accretion during the winter months. Ice accretion can result from freezing rain, snow, supercooled fog, or sea spray. Vessels may use manual ice removal or incorporate thermal methods to maintain safe operations (e.g., steam or heat traces).

2.3 Ship Stability

The marine terminal will not be restricted to specific LNG carriers or NGL product vessels, so vessel-specific stability assessments are not available. There are several procedural controls to ensure LNG carriers and NGL product vessels meet stability requirements.

The *International Convention for the Safety of Life at Sea (SOLAS)* requires LNG carriers and NGL product vessels to have an approved loading and stability manual on board. The data from the manuals is generally incorporated into a class-approved stability computer onboard each LNG carrier or NGL product vessel to facilitate calculation of stability, draft, and hull stresses.

The Project will have an acceptance program for LNG carriers and NGL product vessels. The acceptance program will confirm that LNG carriers and NGL product vessels have the required certifications and have completed a satisfactory Ship Inspection Report Programme (SIRE) inspection in the previous 12 months. The SIRE programme is administered by the Oil Companies International Marine Forum (OCIMF). The SIRE programme requires participating vessels to submit information and undergo inspections to ensure that quality and safety standards are being met. Documentation subject to in-person inspection as part of the SIRE programme, includes the vessel's intact and damage stability booklet. Further details of the vessel acceptance program and SIRE are in Section 3.

2.4 Crewing and Certification Standards

All LNG carriers and NGL product vessels trading internationally must comply with the *International Safety Management (ISM) Code*. LNG carriers and NGL product vessels will be operated by crews meeting the IMO's *Standards for Training and Certification of Watchkeepers, 1995* (STCW). LNG carrier crews must also

have endorsements for the operation of gas carriers. Officers on LNG carriers will also be expected to meet the Society for International Gas Tanker and Terminal Operators (SIGTTO) *LNG Officer Experience Matrix* [6] (see Appendix A).

Crew certification is reviewed as part of the SIRE programme and subject to inspection every 12 months. Further details of the vessel acceptance program and SIRE programme are provided in Section 3.

2.5 Port State Control

All LNG carriers and NGL product vessels calling in Canadian ports are subject to compliance inspections by Transport Canada's Marine Safety Inspectors (MSI), through the port state control (PSC) inspection program [7]. Canada is a party to the *Memorandum of Understanding on Port State Control in the Asia-Pacific Region* (Tokyo MOU) [8] and the *Paris Memorandum of Understanding on Port State Control* (Paris MOU) [9]. Both MOUs aim at eliminating substandard shipping, with countries party to the MOUs working together to ensure compliance with international standards. An inspection database and list of detained ships is maintained by Transport Canada and shared with other countries party to the MOUs [10].

2.6 Shipboard Navigation and Communication Equipment

All LNG carriers and NGL product vessels are equipped as per *SOLAS Chapter IV – Radiocommunications* [11] and *SOLAS Chapter V - Safety of navigation* [11] and operated in compliance with the Radio Regulations [12] by STCW qualified persons. The SIRE programme routinely verifies compliance and operational status to ensure that these requirements are met. The SIRE programme also includes inspection of a variety of bridge and radio room equipment and procedural documentation [13], including:

- Passage plan, chart and publications, navigation related records and checklists
- Paper charts, electronic chart display and information system (ECDIS) for at least the whole of the last voyage
- NAVTEX station including temporary and preliminary corrections
- Inmarsat-C (SAT-C) transceiver, SAT-C navigation warnings
- Radio station equipment including VHF, MF and HF
- Automatic identification system (AIS)
- Master standing order and night orders, night rounds system, look out
- Navigation procedures, echo sounder, course recorded marked 24 hours mode
- Bridge posters
- Logbooks including deck log, compass error log, radar operations log, global maritime distress, and safety system (GMDSS) log
- Planned maintenance system (PMS) regarding navigation equipment and related spares, day signals, etc.
- Emergency equipment on the bridge including line throwing appliance (LTA), emergency position-indicating radio beacon (EPIRB), para-rockets, person over-board equipment, GMDSS radio and batteries
- Bridge wing and monkey island antenna and lighting checks
- Fire detection panel and fire drill in logbook
- Voyage data recorder (VDR) equipment check including the save function
- Bridge navigational watch alarm system (BNWAS) test and GPS anchor alarm

Further details of the vessel acceptance program and SIRE are in Section 3.

The Navigation Safety Regulations [14], under the *Canada Shipping Act, 2001* [15], require vessels of 300 gross tonnage or more engaged on an international voyage, and domestic vessels of 500 gross tonnage or more, to be fitted with an AIS. The AIS transponder automatically provides information about the vessel's identity, location, course, speed, status, and other safety-related information. AIS signals can be received by other vessels within range, and by land and satellite-based receivers.

2.7 LNG Carrier Design and Construction

LNG carrier construction must comply with the *International Code for the Construction and Equipment of Ships Carrying Liquefied Gases in Bulk* (IGC Code) [16], published by the IMO. The *IGC Code*, amongst other requirements, lays out information on materials for construction, structural strength, performance, safety features and equipment, and stability requirements.

Before entering service, an LNG carrier is issued with certificates confirming its construction is to an acceptable standard. These certificates are valid for a limited time. Renewal inspections must demonstrate vessels are being maintained. LNG carriers built and maintained to the *IGC Code* will be issued an International Certificate of Fitness for the Carriage of Liquefied Gases in Bulk (i.e., an IGC Certificate).

LNG carriers primarily have two basic designs: the spherical tank type, and the membrane tank type (see Figure 4).



Figure 4 – Spherical-type LNG carrier (left) and membrane-type LNG carrier (right)

Spherical-type containment systems have been used in LNG carriers up to 182,000 m³ capacity. Membrane tanks are now more common in larger LNG carriers due to the more efficient use of space within the hull. The two systems are different, both in appearance and design, but they perform the same primary function of maintaining cold cargo tank temperatures to reduce boil off and prevent the loss of containment or ingress of air or oxygen into the cargo tanks.

The outer hull of LNG carriers is constructed from a grade of steel for the stresses developed by the cargo loads and metocean conditions. This steel becomes brittle at cold temperatures. Therefore, LNG carrier cargo tanks must be constructed of a metal alloy that can withstand cold temperatures of LNG (approximately -162 degrees Celsius). The tanks and pipelines which hold the LNG cargo (i.e., the “containment system”), are constructed of either stainless-steel (Austenitic), Invar Nickel steel, or an aluminium alloy. These materials can withstand cold temperatures. Equipment which contacts LNG (e.g., piping, blanks, valves, and pumps) must also be able to withstand cold temperatures. Information on the materials used for LNG carrier construction is in Chapter 6 of the *IGC Code*.

2.7.1 Cargo Containment – Spherical-Type

The tanks onboard spherical LNG carriers are known as “integral” or “self-supporting” tanks. These tanks do not contribute to the structural strength of the LNG carrier but are rather “inserted” into the LNG carrier hull and secured. Advantages to these tanks include:

- No high slosh loads when full
- The vessels can be loaded or discharged at even keel; any cargo will automatically pool at the bottom of the tank
- The tanks are known as “self-supporting”, meaning that the structure of the tanks does not rely on the ship’s hull for support or containment
- The tanks can be loaded up to 99.5%, giving an increased load capability
- The small surface area minimizes heat ingress and corresponding boil off

Figure 5 shows a cross-section of a typical spherical LNG carrier with details of the containment and insulation systems.

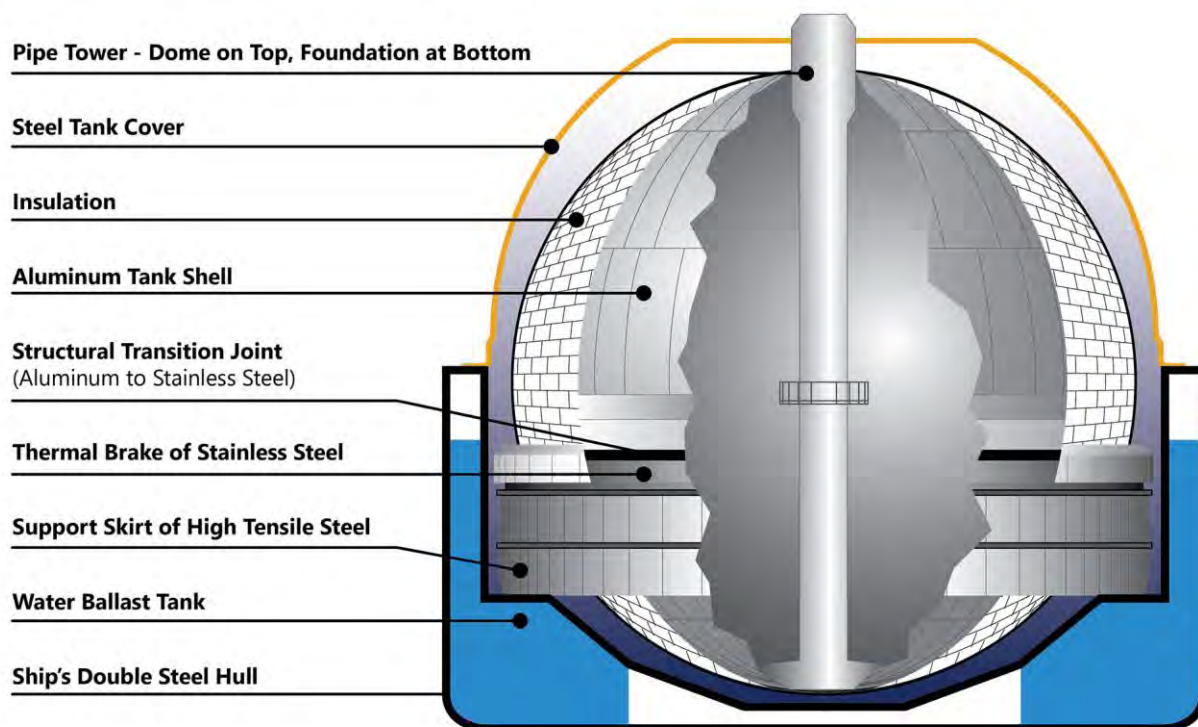

Figure 5 - Cross-section through a typical spherical carrier showing cargo containment arrangement (source Lloyd’s Register)

2.7.2 Cargo Containment – Membrane-Type

With the development of larger LNG carriers, spherical tanks became less efficient. The membrane tank system is more efficient because it is lighter and more of the internal volume of the hull can be dedicated to cargo. Membrane tanks are not “self-supporting” and use the LNG carrier hull for support. Loads from LNG cargo are transferred to the LNG carrier hull through a layer of insulation.

There are principally two designs for membrane tanks: the Gaz Transport No. 96 (developed by Gaz Transport) and the Technigaz Mk III (developed by Technigaz). Gaz Transport and Technigaz merged and

are now called Gaztransport and Technigaz (GTT). Both types of tanks are constructed by lining the inner hull with two layers of a non-permeable, insulating membrane.

For GTT No. 96 tanks, the membrane consists of two identical Invar barriers, termed the primary and secondary barriers (see Figure 6). For GTT Mk III tanks, the system is constructed by fitting a primary stainless-steel membrane and secondary triplex membrane with two insulation layers (see Figure 7 and Figure 8).

The insulation spaces with membrane tanks are purged with nitrogen (i.e., no oxygen), so there is no risk of a flammable atmosphere developing if a cargo tank leaks. Nitrogen holds no moisture, which could lead to frost heave and reduction of insulating properties. The nitrogen is sampled on discharge to detect hydrocarbons that would indicate any leakage.



Figure 6 – GTT No. 96 Invar primary and secondary barrier

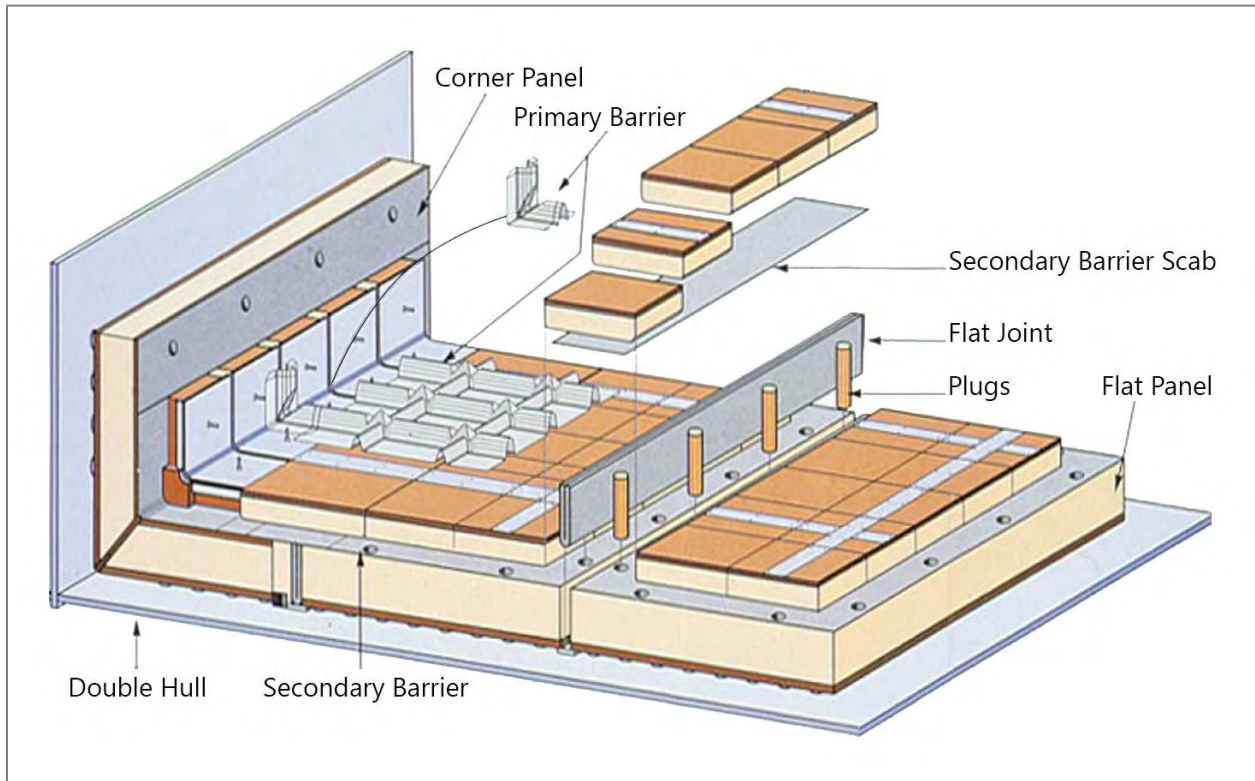

Figure 7 – GTT MK III stainless-steel primary barrier, triplex secondary barrier

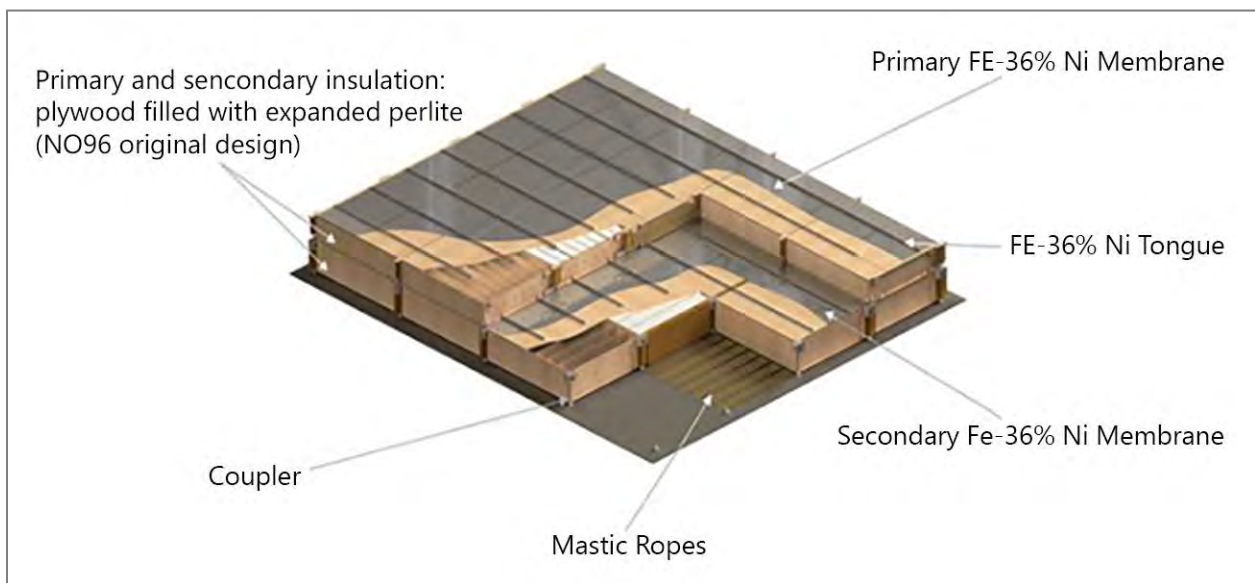

Figure 8 – Cutaway view of LNG carrier with GTT Mark III Tank, and details of GTT Mk III insulation (source GTT)

2.7.3 Cargo Transfer Systems

See Section 3.2 of the *Terminal Plans and Cargo Transfer Report* [17] for a description of LNG loading systems at the marine terminal.

2.7.4 Propulsion and Steering Systems

Conventional LNG carriers have historically been powered by steam turbine engines driving single propellers. Steam was produced in boilers heated by burning boil off gas (BOG) collected from the LNG cargo tanks during transit. On the ballast voyage, the boilers are fuelled by BOG from a small amount of LNG retained onboard (otherwise known as "heel") to keep the cargo tanks cold and ready for loading at the next port.

Modern designs of power and propulsion plants for LNG carriers have improved on the fuel efficiency of steam turbines, and may instead utilize:

- **Dual / tri-fuel diesel electric plants** powered by natural gas from the cargo tanks, low sulphur diesel oil or low sulphur heavy fuel oil. The diesel units provide power to the electric propulsion motors and for ships systems
- **Slow speed engines** fuelled by low sulphur diesel oil, low sulphur marine fuel oil or natural gas from the cargo tanks
- **Gas turbine electric power** with waste heat-recovery, utilizing forced BOG or natural BOG with intermediate fuel oil is under evaluation for future vessels

The large above water surface areas of the hull and superstructure make LNG carriers susceptible to sheer wind forces at slow speeds. Assisted by tugs, berthing and departure operations can be completed safely.

Due to the hull form and use of slow speed engines, newer LNG carriers are often fitted with twin propellers to provide power efficiently at relatively shallow drafts. Additional benefits include redundancy in the event of mechanical failure and increased manoeuvrability, reducing the reliance on tugs. High lift rudders (e.g., Becker type) and thrusters, bow and stern, may also be incorporated into the design, while smaller vessels may be fitted with variable-pitch propellers.

2.7.5 Auxiliary Power Systems

When in port, LNG carriers use generators to provide power. These are primarily LNG powered, medium-speed engines also capable of running on low sulphur marine diesel oil or low sulphur marine heavy oil. The engines can change between grades with no loss or interruption in power to the LNG carrier.

2.7.6 Main and Auxiliary Engine Cooling Systems

As the fuel and propulsions systems used on LNG carriers vary, so do the types of engine cooling systems. All large LNG carriers, including steam vessels, use a variety of heat-recovery systems to capture waste heat and reuse it to increase overall thermal efficiency.

2.7.7 Manoeuvring Data

At sea, LNG carriers have an average service speed of approximately 19.5 kns. When approaching port, LNG carriers will reduce from full speed to a full manoeuvring speed of approximately 12 kns to 14 kns over about one hour. Effective "dead slow" ahead speed for LNG carriers will be approximately 6 kns. When manoeuvring astern, the effective power of the propellers will be approximately 70%.

Large LNG carriers rarely have bow or stern thrusters and use tugs during berthing and unberthing at terminals. LNG carriers handle like other large vessels such as container vessels. Each LNG carrier has a pilot card that informs the vessel crew and pilots of the principal handling characteristics for the LNG carrier (e.g., turning circle and stopping distances).

The turning circle will vary according to the specifics of the individual LNG carrier, speed, loading condition, water depth and metocean conditions. The turning circle of an LNG carrier of approximately

90,000 tonnes displacement (135,000 m³ capacity) proceeding in deep water at 12 kns, putting its helm hard a' starboard, (45 degrees) is in Figure 9.

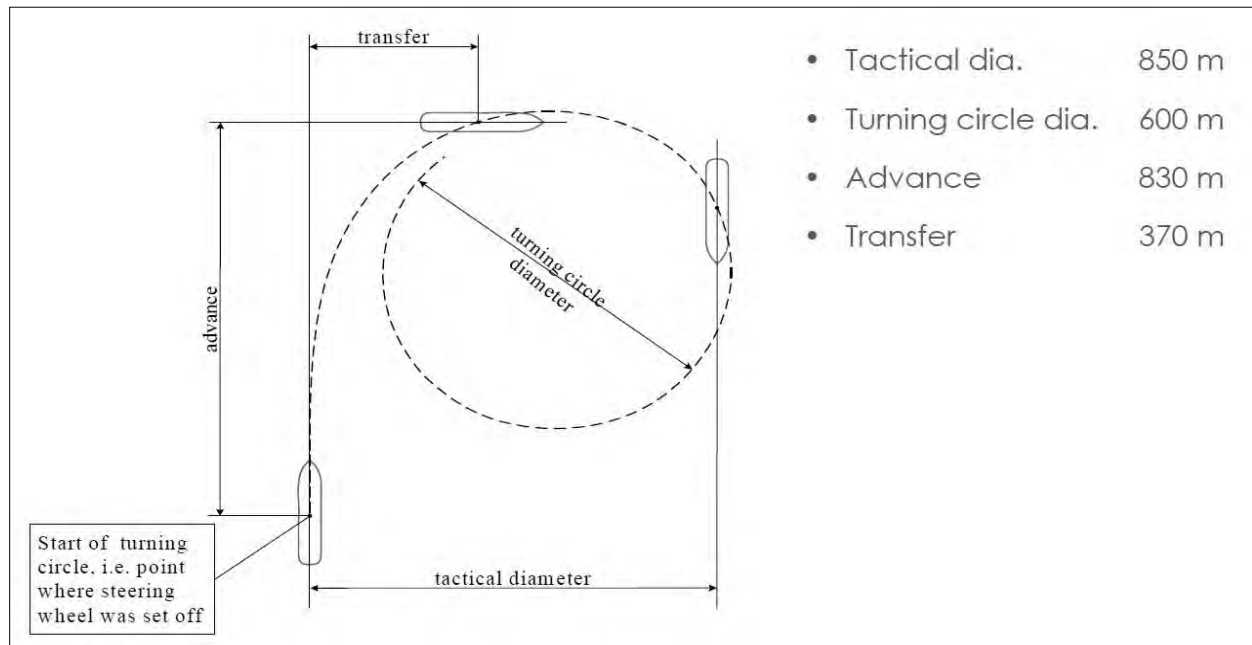

Figure 9 – Representative LNG carrier turning distance at 12 kns speed

2.7.8 Safety Systems

LNG carriers have several safety features, including:

- 1) **Overflow protection:** Multiple sensors within the tanks detect when certain levels have been reached, with upper levels initially sounding alarms and then automatically shutting offloading before the tank can be overfilled.
- 2) **Over-pressure protection:** The LNG containment tanks are fitted with pressure relief valves for over-pressure protection.
- 3) **Fill range limits:** As the LNG carriers move due to waves and manoeuvring, so does their liquid cargo, with the "free surface effect" exerting forces on the LNG carrier. In extreme cases, the forces from sloshing liquid can influence LNG carrier stability and the integrity of the insulated tanks onboard. Minimizing these effects is part of LNG carrier design, with mitigation measures including:
 - a) Use of multiple, separate tanks on all LNG carriers.
 - b) Tanks are tapered at the top to reduce sloshing and reinforced to withstand wave forces.
 - c) Controlled tank filling. All LNG carriers have defined allowable fill ranges which vary by LNG carrier. Typically, low levels are permitted (0 to 10%) as there is insufficient fluid to create large forces, and high fill levels are permitted as the tapering shape of the tanks limits the size of the free surface that can be created. Membrane LNG carriers without strengthened containment systems typically may not proceed to sea with LNG levels between 10% and 75% [18].
- 4) **Secondary BOG Management systems:** Most modern LNG carriers are fitted with dual-fuel engines which allow the LNG carrier to utilize BOG as a fuel during the journey or run-on fuel oil if BOG is not available. However, if excess BOG is produced, the LNG carriers include secondary management systems to either reliquefy or burn the excess gas.

2.8 NGL Product Vessel Design and Construction

NGL product vessels have steel cargo tanks designed to carry a variety of liquid cargoes. As required under international conventions and Canadian statutes, all LNG carriers and NGL vessels will have double hulls for safety. This requirement was introduced by the *International Convention for the Prevention of Pollution from Ships (MARPOL)* in 1992 [19], with the phase-out of single-hulled vessels accelerated by IMO member states in 2003.

NGL product vessels will be filled using loading hoses at the marine terminal. The loading sequence for condensate will be like the process for loading LNG with a pre-transfer meeting, connection, start of loading, cargo ramp-up, loading, end of loading, purging and disconnections. The condensate is stored at ambient temperature and therefore there is no cooldown process like there is for LNG. The quantity of condensate to be loaded is also less than LNG and will be loaded at lower handling rates, which will be determined during detailed project planning.

2.8.1 Propulsion and Steering Systems

The NGL product vessels are significantly smaller than the design LNG carriers and will have a reduced service speed of approximately 13 to 16 kns. For ships within the design NGL product vessel range of 5,000 to 30,000 dwt, the propulsion system is likely to be four-stroke or two-stroke diesel engines [20].

All LNG carriers and NGL product vessels have redundant steering gear. Older NGL product vessels are likely to utilize a single rudder and single fixed-pitch propeller. Newer NGL product vessels may have twin propulsion systems and rudders.

2.8.2 Manoeuvring Data

The range of NGL product vessels will have a variety of manoeuvring characteristics. However, in all cases the turning circle and stopping distance will be significantly less than for the LNG carriers. As the LNG carriers and NGL product vessels will utilize the same marine route and the same tug support, the navigational safety of the marine route is governed by the manoeuvring capabilities of the LNG carriers.

3 Vessel Acceptance Program

The Project will have an acceptance program for LNG carriers and NGL product vessels. This includes checking that LNG carriers and NGL product vessels are compatible with the Project's marine terminal design and operations.

The vessel acceptance program also includes a vetting component. The vetting process involves checking LNG carriers and NGL product vessels have up-to-date certifications and have not been flagged by other operators or applicable agencies as out of compliance with industry requirements. The Project's vetting will use the SIRE programme.

3.1 Compatibility Verification

Before an LNG carrier or NGL product vessel visits the marine terminal, a compatibility study must be submitted. The study is to ensure that the LNG carrier or NGL product vessel can safely berth and moor at the marine terminal and that the cargo transfer and safety systems are compatible with the marine terminal. The primary elements of the compatibility study include:

- **Vessel Dimensions:** Ensure that the LNG carrier fits on the berth at all levels of tide and draft. Dimensions are generally relative to the vapour manifold which determines the LNG carrier position on the berth. The windage area provides information regarding the additional wind loads tugs will need to account for
- **Mooring and Fendering Arrangements:** Ensuring that the parallel body of the LNG carrier is compatible with the fendering arrangements at all levels of tide and draft. A mooring study will identify the loads on the mooring lines under a range of weather and current conditions to validate that the LNG carrier can remain safely moored up to the operating limits of the marine terminal
- **Manifold Arrangements:** Confirm compatibility with the transfer arrangements and that the LNG carrier manifold will stay within the operating limits of the transfer system at all levels of tide and draft and weather conditions. The ship-shore link (SSL) configuration and emergency shutdown (ESD) compatibility will be checked before loading operations commence
- **Gangway Arrangements:** LNG carriers have narrow decks and structures on the decks that can make it challenging to land shore gangways. The study will identify the landing location and allow any challenges to be addressed before the LNG carrier arrival. There will be no routine operational access between the FLNGs and LNG carriers or NGL product vessels at berth. Transfer of personnel will be to support vessels on the seaward side of the LNG carrier or NGL product vessel

3.2 Vetting Process

LNG carriers and NGL product vessels visiting the marine terminal must have completed a SIRE inspection within the 12 months prior to the visit. The SIRE programme is facilitated by OCIMF. The initial focus of the SIRE programme was tankers. However, the SIRE programme has been extended to cover a wider range of vessels, including LNG carriers.

The inspection looks for compliance and adherence with international requirements and best practices. The inspection also addresses the management and operation of the LNG carrier or NGL product vessel. The inspection is standardized and includes several core questions, deemed critical, which are always checked. Besides the SIRE inspection, the LNG carrier or NGL product vessel must advise on the outcomes of any PSC inspections within the previous 12 months.

The responses to the SIRE and PSC questions determines if the LNG carrier or NGL product vessel meets the requirements to safely visit the marine terminal. If there are issues outstanding, a further inspection can be completed once those issues have been addressed.

The focal points for the SIRE inspection are listed below, and a more detailed breakdown of the chapters is included in Appendix B.

- 1) Vessel, Operator, and Inspection Particulars
- 2) Certification and Documentation
- 3) Crew Management
- 4) Navigation and Communications
- 5) Safety Management
- 6) Pollution Prevention
- 7) Maritime Security
- 8) Cargo and Ballast Systems
- 9) Mooring and Anchoring
- 10) Machinery Spaces
- 11) General Appearance and Condition
- 12) Ice Operations

References

- [1] Westmar Advisors Inc., "Marine Route," 1220197_P01_22_RPT_0001, 2023.
- [2] International Group of Liquefied Natural Gas Importers, "GIIGNL Annual Report - 2022," GIIGNL, Annual Report 3 ed., 2022. Accessed: Aug. 30, 2022. [Online]. Available: https://giignl.org/wp-content/uploads/2022/05/GIIGNL2022_Annual_Report_May24.pdf
- [3] Exxon Mobil, "Interactive World LNG Dashboard | V4.0." Accessed: Aug. 23, 2022. [Online]. Available: http://gulfpub-gisstg.esriemcs.com/pe_exxonmobil_dash/index.html
- [4] K-J Millar, "Record-breaking vessel berths in Prince Rupert," Prince Rupert Northern View. Accessed: Sep. 28, 2022. [Online]. Available: <https://www.thenorthernview.com/news/record-breaking-vessel-berths-in-prince-rupert/>
- [5] International Association of Classification Societies, "Classification societies – their key role." Accessed: Dec. 16, 2022. [Online]. Available: <https://iacs.org.uk/media/8875/classification-societies-key-role.pdf>
- [6] Society of International Gas Tanker and Terminal Operators, "SIGTTO LNG and LPG Experience Matrix Guidelines for Use." Witherby Seamanship, 2016. Accessed: Sep. 08, 2022. [Online]. Available: <https://www.sigtto.org/media/2014/sigtto-experience-matrix-guidance-document.pdf>
- [7] Transport Canada, "Inspection of non-Canadian commercial vessels." Accessed: Sep. 28, 2022. [Online]. Available: <https://tc.canada.ca/en/marine-transportation/vessel-inspection-certification/inspection-non-canadian-commercial-vessels>
- [8] Tokyo MOU, "Memorandum of Understanding on Port State Control in the Asia-Pacific." Accessed: Aug. 06, 2023. [Online]. Available: <https://www.tokyo-mou.org/>
- [9] Paris MoU on Port State Control, "Paris MoU." Accessed: Aug. 06, 2023. [Online]. Available: <https://www.parismou.org/>
- [10] Prince Rupert Port Authority, "Inspections from Port State Control." Accessed: Sep. 28, 2022. [Online]. Available: https://www.rupertport.com/info_guide/15-port-inspections/
- [11] International Maritime Organization, "International Convention for the Safety of Life at Sea (SOLAS)." Accessed: Aug. 22, 2022. [Online]. Available: [https://www.imo.org/en/About/Conventions/Pages/International-Convention-for-the-Safety-of-Life-at-Sea-\(SOLAS\),-1974.aspx](https://www.imo.org/en/About/Conventions/Pages/International-Convention-for-the-Safety-of-Life-at-Sea-(SOLAS),-1974.aspx)
- [12] International Telecommunication Union (ITU), "Radio Regulations 2020." Accessed: Aug. 06, 2023. [Online]. Available: <https://www.itu.int/hub/publication/r-reg-rr-2020/>
- [13] Jab Firoz, "SIRE Inspection on Ships," Marine Engineering Study Materials. Accessed: Aug. 29, 2022. [Online]. Available: <https://marineengineeringonline.com/sire-inspection-on-ships/>
- [14] *SOR/2020-216 | Navigation Safety Regulations, 2020*. CanLII. Accessed: Jul. 26, 2023. [Online]. Available: <https://www.canlii.org/en/ca/laws/regu/sor-2020-216/213728/sor-2020-216.html>
- [15] *SC 2001, c 26 | Canada Shipping Act, 2001*. CanLII. Accessed: Jul. 26, 2023. [Online]. Available: <https://www.canlii.org/en/ca/laws/stat/sc-2001-c-26/160998/sc-2001-c-26.html>
- [16] International Maritime Organization, "International Code for the Construction and Equipment of Ships Carrying Liquefied Gases in Bulk (IGC Code)." Accessed: Sep. 07, 2022. [Online]. Available: <https://www.imo.org/en/OurWork/Environment/Pages/IGCCode.aspx>
- [17] Westmar Advisors Inc., "Terminal Plans and Cargo Transfer," 1220197-P01-25-RPT-0001, 2023.

- [18] Lloyd's Register, "Guidance document Operation of Membrane LNG ships to Reduce the Risk of Damage due to Sloshing." Accessed: Sep. 20, 2022. [Online]. Available: <https://documents.pub/document/guidance-on-the-operation-of-membrane-lng-ships-to-reduce-the-risk-of-damage.html?page=1>
- [19] International Maritime Organization, "Construction Requirements for Oil Tankers - Double Hulls," IMO. Accessed: Aug. 30, 2022. [Online]. Available: <https://www.imo.org/en/OurWork/Environment/Pages/constructionrequirements.aspx>
- [20] MAN Energy Solutions, "Propulsion Trends in Tankers." Oct. 2021. Accessed: Aug. 30, 2022. [Online]. Available: <https://vdocument.in/propulsion-trends-in-tankers.html?page=1>

Appendix A

SIGTTO LNG Officer Experience Matrix

DRAFT



A SIGTTO LNG Officer Experience Matrix

Navigating Officer Sea Experience - All Vessels		
	Combined Sea Time	Individual Minimum Sea Time as Certificated Officer
Master	4 Years	4 Years
Chief Officer	At Chief Officer or Above	2 Years
Navigating Officer LNG Specific Experience		
	Combined	Individual Minimum Experience Sea Time as Certificated Officer
Master	2 Years in Rank on LNG Vessels	4 years experience with another Dangerous Cargo Endorsement then a minimum 30 days intensive training (to include at least one load and discharge operation) + completion of SIGTTO competency standards training for LNG or 2 year LNG specific experience or 2 years LPG experience + completion of SIGTTO competency standards training for LNG.
Chief Officer		2 years experience with another Dangerous Cargo Endorsement then a minimum 30 days intensive training (to include at least one load and discharge operation) + completion of SIGTTO competency standards training or 1 year LNG specific experience or 1 years LPG experience + completion of SIGTTO competency standards training for LNG.
Engineering Officer Sea Experience – All Vessels		
	Combined	Individual Minimum Sea Time as Certificated Engineering Officer
Chief Engineer	4 Years at Second Engineer or Above	4 Years
2nd Engineer		2 years
Engineering Officer Steam LNG Vessel Experience		
	Combined	Individual
Chief Engineer	2 Years in Rank on Steam LNG Vessels	4 years diesel experience with a minimum of 30 days intensive training + completion of SIGTTO competency standards training for LNG + Completion of SIGTTO competency standards for steam engineers, or a flag State issued Steam Endorsement, or 2 years steam experience and completion of SIGTTO competency standards for steam engineers, or two years steam LNG experience.
2nd Engineer		2 years diesel experience with a minimum of 30 days intensive training + completion of SIGTTO competency standards training for LNG + Completion of SIGTTO competency standards for steam engineers, or a flag State issued Steam Endorsement, or 1 years steam experience and

		completion of SIGTTO competency standards for steam engineers, or 1 year steam LNG experience.
Gas Engineer		1 year as a certified engineering officer on a LNG carrier or a minimum of 30 days intensive training + completion of SIGTTO competency standards training for LNG (Note 4)
Engineering Officer Diesel & Diesel Electric LNG Vessel Experience		
Chief Engineer	2 Years in Rank on LNG Vessels	4 years steam and / or diesel experience with a minimum of 30 days intensive training + completion of SIGTTO competency standards training for LNG (unless 1 year completed on LNG vessels) (Note 4 + 5 + 6)
2nd Engineer		2 years steam and / or diesel experience with a minimum of 30 days intensive training + completion of SIGTTO competency standards training for LNG (unless 1 year completed on LNG vessels) (Note 4+5 +6)
Gas Engineer		1 year as a certified engineering officer on a LNG carrier or a minimum of 30 days intensive training + completion of SIGTTO competency standards training for LNG (Note 4 + 6)

Notes:

- 1) 1st officer and 1st assistant engineer terminology considered equivalent to chief officer and 2nd engineer for purposes of these guidelines.
- 2) Sea time refers to time onboard a vessel and may include an allowance for time served working in a relevant capacity within the ship management office, standing by a new build or conversion or laid-up. Such time shall be treated as 1 / 3rd actual time up to a maximum period of one year.
- 3) Intensive training to be for not less than 30 days in rank the individual will be assuming on LNG vessel. Such individual shall also be required to have completed the relevant SIGTTO competency standard training commensurate with position. During this time the observer should become familiar with the company's SMS Manuals as a whole but specifically as they affect their position onboard.
- 4) Senior engineering officers sailing vessels with Gas Combustion Units and Re-liquefaction Define.
- 5) plants and other ship specific equipment should have thorough equipment specific training on the operation and maintenance of this equipment.
- 6) Engineer officers sailing on vessels with DE should have thorough equipment specific training on operation and maintenance of the engines and electric equipment.
- 7) Seatime time assigned to new building and/or repair to be credited as experience up to a maximum of three months.
- 8) Companies should ensure that procedures are in place to ensure that adequate time and familiarization is given for relieving officers to become fully appraised of the differences in operation and limitations of a containment system with which they have no or limited experience. This should consist of at least one cargo operation.
- 9) For combined LNG / LPG carriers some relaxation of these requirements may be considered if it can be demonstrated that the officer has experience with liquefied gases in a similar containment system.

Appendix B

SIRE Inspection Questionnaire - Chapters

DRAFT



B SIRE Inspection Questionnaire - Chapters

- 1. Vessel, Operator, and Inspection Particulars**
- 2. Certification and Documentation**
 - 2.1. Certification
 - 2.2. Management Oversight
 - 2.3. Structural Assessment
 - 2.4. Defect Management
 - 2.5. Management of Change
 - 2.6. Statutory Management Plans
 - 2.7. Safety Management System
 - 2.8. General Information
- 3. Crew Management**
 - 3.1. Crew Qualification
 - 3.2. Crew Evaluation
 - 3.3. Crew Training
 - 3.4. Crew Compliance
 - 3.5. Crew Familiarization
- 4. Navigation and Communications**
 - 4.1. Navigation Equipment
 - 4.2. Navigational Procedures
 - 4.3. Bridge and Machinery Space Team Management
 - 4.4. Communications Equipment and Procedures
 - 4.5. DP and Shuttle Tanker Specialist Procedures and Equipment
- 5. Safety Management**
 - 5.1. Emergency Response Plans and Drills
 - 5.2. Fixed Fire Protection Systems
 - 5.3. Portable Fire Fighting Appliances
 - 5.4. Life-Saving Appliances
 - 5.5. Permits to Work
 - 5.6. Fixed and Portable Gas Detecting Systems
 - 5.7. Safety Management
 - 5.8. Area Safety Inspections
 - 5.9. Lifting and Rigging
 - 5.10. Safe Access
 - 5.11. Sample Management
 - 5.12. Safety Equipment
- 6. Pollution Prevention**
 - 6.1. Pollution Prevention – Record Books
 - 6.2. Cargo and Bunker Operations
 - 6.3. Ballast Operations

- 6.4. Deck Area Pollution Prevention
- 6.5. Machinery Space Pollution Prevention
- 6.6. Oil Discharge Monitors

7. Maritime Security

- 7.1. Ship Routing
- 7.2. Ship Hardening and Access Control
- 7.3. Communications and Monitoring
- 7.4. Ship Security Officer
- 7.5. Cyber Security

8. Cargo and Ballast Systems

- 8.1. Oil
- 8.2. Chemicals
- 8.3. Oil and Chemicals
- 8.4. LPG
- 8.5. LNG
- 8.6. Gas (common to all vessels under IGC Code)
- 8.7. Shuttle Tanker Cargo Operations
- 8.8. OBO / Combination Carriers
- 8.9. All Types

9. Mooring and Anchoring

- 9.1. Mooring Equipment Management
- 9.2. Emergency Towing Arrangements
- 9.3. Mooring and Anchoring Procedures
- 9.4. Mooring and Anchoring Team Management
- 9.5. STS Operation Management
- 9.6. Single Point Mooring
- 9.7. Shuttle Tanker Mooring Systems

10. Machinery Spaces

- 10.1. Engineering Procedures
- 10.2. Machinery Status
- 10.3. Safety Management
- 10.4. Planned Maintenance Systems
- 10.5. Conventional Bunkering Management
- 10.6. LNG Bunkering Management
- 10.7. Fire Protection Measures

11. General Appearance and Condition – Photograph Comparison

- 11.1. to 11.1.36 All Vessels
- 11.1.40 to 11.1.42 Addition for Crude / Product / Chemical / Shuttle / OBO
- 11.1.50 to 11.1.52 Additional for LPG Pressurized
- 11.1.60 to 11.1.62 Additional for LNG Refrigerated
- 11.1.70 to 11.1.72 Additional for LNG Membrane-Type
- 11.1.80 to 11.1.82 Additional for LNG Moss Type

11.1.90 to 11.1.95 Additional for Specialized Bow Loading Shuttle Tanker

12. Ice Operations

12.1. Ice Operations Training

12.2. Sub-Zero Life-Saving Appliances (LSA) and Fire Fighting Appliances (FFA) Procedures

12.3. Sub-Zero Machinery Operation Procedures

12.4. Sub-Zero Cargo and Ballast Operation Procedures

12.5. Sub-Zero Deck Machinery Operation Procedures

1 **ATTACHMENT E.5 TERMINAL PLANS AND CARGO TRANSFER**

Ksi Lisims LNG
Navigation Safety Assessment

Terminal Plans and Cargo Transfer

11 October 2023



Disclaimer

This report is not intended to stand alone without reference to the instructions given to Westmar by Ksi Lisims LNG, communications between Westmar and Ksi Lisims LNG, and any other reports, proposals or documents prepared by Westmar for Ksi Lisims LNG under the governing contract between Westmar and Ksi Lisims LNG. To understand the suggestions, recommendations and opinions expressed herein, reference must be made to all relevant documents and communications.

This report has been prepared only for the purposes that are set out in the governing contract between Westmar and Ksi Lisims LNG. The findings, recommendations, suggestions and or opinions expressed in this report are only applicable to the purposes for which the report is expressly provided, and then only to the extent that there has been no material alteration to or variation from the information provided or available to Westmar.

The information and opinions expressed in this report are for the sole use and benefit of Ksi Lisims LNG. No other party may use or rely upon the report or any portion thereof without Westmar's prior written consent, and such use shall be on terms and conditions as Westmar expressly approves. Ownership in and copyright for the contents of the report belong to Westmar. Any use which a third party makes of the report is the sole risk and responsibility of such third party. Westmar accepts no responsibility whatsoever for loss or damages suffered by any third party in relation to use of this report.

Company Details

Westmar Advisors Inc.
700 - 1901 Rosser Avenue
Burnaby, BC, V5C 6R6

T 604 770 4787

info@westmaradvisors.com

Table of Contents

Abbreviations	v
Preface	x
1 Introduction.....	1
2 Site Plans and Technical Data	2
2.1 Project Description	2
2.1.1 Floating and Fixed Structures	2
2.1.2 Tug Berth	3
2.1.3 Shoreline and Scour Protection	3
2.1.4 Turning Basins and Manoeuvring Areas	3
2.1.5 Separation Between Berths and Navigation Channel	4
2.1.6 Anchorage Areas	4
2.1.7 Underwater Installations.....	4
2.1.8 Dredging and Fill Operations	5
2.1.9 Site Wind Conditions	5
2.1.10 Site Wave Conditions.....	5
2.1.11 Tides and Currents	6
2.2 Terminal Design, Operating and Safety Parameters	7
2.2.1 Codes, Standards, and Guidelines	7
2.2.2 Design Vessels.....	7
2.2.3 Design Loads.....	8
2.2.4 FLNG and LNG Carrier Mooring Analysis.....	8
2.2.5 Marine Terminal Identification and Lighting	9
2.2.6 Pilot Access	9
2.2.7 Operating Parameters	9
3 Cargo Transfer Systems	10
3.1 Storage and Loading System	10
3.2 Process Description	10
3.2.1 LNG Loading and Circulation.....	10
3.2.2 Loading Arm Design.....	11
3.2.3 Utilities in Storage and Loading System	11
3.2.4 Loading System Emergency Shutdown	12
3.2.5 Ship Stability During Loading.....	12
4 Berth Procedures and Provisions	13
4.1 Navigation Simulation	13
4.2 Maximum Operating Parameters	13
4.3 Monitoring Systems	13
4.3.1 Quick Release Hooks and Mooring Load Monitoring System	13
4.3.2 Docking Assist System.....	14
4.3.3 Metocean Monitoring System.....	14
4.4 Berthing Strategy	14

4.5	Mooring Strategy	14
4.6	Safety and Security Plans	15
4.6.1	Safety Plans.....	15
4.6.2	Security Plans.....	15
References.....		16
A	Codes, Standards and Guidelines.....	18

Appendices

Appendix A Codes, Standards and Guidelines

List of Tables

Table 1 – Forecast tidal levels at the Site.....	7
Table 2 - Current speed (cm/s) near the Site [6].....	7
Table 3 – Preliminary operating limits	13

List of Figures

Figure 1 - Wind Rose for Grey Islet, 1994-2022 (left); and Wil Milit, 2021-2022 (right) [6].....	5
Figure 2 - Timeseries of significant wave height near the Site [6].....	6
Figure 3 - Significant wave height near the Site [6]	6
Figure 4 - Mooring points on the FLNG.....	15

Abbreviations

Abbreviation	Description
°C	degrees Celsius
ABS	American Bureau of Shipping
ADCP	acoustic doppler current profiler
AIS	automatic identification system
AIS ATON	automatic identification system aid to navigation
AK	Alaska
ANSI	American National Standards Institute
ARI	average recurrence interval
ATON	aids to navigation
BC	British Columbia
BCCP	British Columbia Coast Pilots Ltd.
BCER	BC Energy Regulator
BNWAS	bridge navigational watch alarm system
BOG	boil off gas
BV	Bureau Veritas
CCG	Canadian Coast Guard
CHS	Canadian Hydrographic Services
CMB	continuous marine broadcast
CPAs	Compulsory Pilotage Areas
DAS	docking assist system
deg	degree
DFO	Fisheries and Oceans Canada
DNV	Det Norske Veritas
dwt	deadweight tonnage
EA	environmental assessment
ECCC	Environment and Climate Change Canada
ECDIS	electronic chart display and information system
EDG	emergency diesel generators
EEBD	Emergency Escape Breathing Device
EMSA	enhanced maritime situation awareness
ENC	electronic navigational chart
EOC	Emergency Operations Centre
EPIRB	emergency position-indicating radio beacon

Abbreviation	Description
ERS	emergency release system
ESD	emergency shut down
ETA	estimated time of arrival
EU	environmental unit
FEED	front-end engineering design
FFA	fire fighting appliances
FLNG	floating liquefaction, storage, and off-loading barge
FMBS	full mission bridge simulation
FMO	Federal Monitoring Officer
FSA	Formal Safety Assessment
FSRU	floating storage and regassification units
GMDSS	Global Maritime Distress, and Safety System
GNSS	Global Navigation Satellite System
GTT	Gaztransport and Technigaz
HFO	heavy fuel oil
HNS	hazardous and noxious substances
Hs	significant wave height
IACS	International Association of Classification Societies
IALA	International Association of Marine Aids to Navigation and Lighthouse Authorities
ICS	Incident Command System
IGC Code	<i>International Code for the Construction and Equipment of Ships Carrying Liquefied Gases in Bulk</i>
ILO	International Labour Organization
IMO	International Maritime Organization
ISGOTT	<i>International Safety Guide for Oil Tankers and Terminals</i>
ISM	International Safety Management
ISPS	<i>International Ship and Port Facility Security Code</i>
kHz	kilohertz
km	kilometre
kn	knot
LBP	length between perpendiculars
LFL	lower flammability limit
LLWLT	lower, low water, large tide
LNG	liquefied natural gas
LOA	length overall
LOS	level of service
LPG	liquefied petroleum gas

Abbreviation	Description
LR	Lloyd's Register
LSA	life-saving appliances
LSIR	location specific individual risk
LTA	line throwing appliance
m	metre
m	metres per second
m ²	square metres
m ³	cubic metres
m ³	cubic metres
m ³ / hour	cubic metres per hour
MARPOL	<i>International Convention for the Prevention of Pollution of Ships</i>
MCTS	Marine Communications and Traffic Services
MDO	marine diesel oil
MGO	marine gas oil
MOF	material off-loading facility
MOU	Memorandum of Understanding
MSI	Marine Safety Inspectors
MSOC	Marine Security Operations Centre
MTBE	methyl tertiary butyl ether
mtpa	million tonnes per annum
NASP	National Surveillance Aerial Program
NAVTEX	Narrow Band Direct Printing Telegraphy
NAVWARN	navigational warnings
NGL	natural gas liquid
NK	Nippon Kaiji Kyokai
NLG	Nisga'a Lisims Government
NLS	Noxious Liquid Substances
NOA	notice of arrival
North Coast	north coast of British Columbia
NOTMAR	Notices to Mariners
NRA	BCCP / PPA Navigational Risk Assessment
NSA	navigation safety assessment
NW	northwest
OCIMF	Oil Companies International Marine Forum
ODAS	ocean data acquisition system
OGAA	<i>Oil and Gas Activities Act</i>

Abbreviation	Description
OPP	Oceans Protection Plan
OPRC	<i>International Convention on Oil Pollution Preparedness, Response and Co-operation</i>
OSC	On-Scene Commander
P&I	protection and indemnity (insurance)
P&I	protection and indemnity
PAH	polycyclic aromatic hydrocarbons
PAIR	Pre-Arrival Information Reports
PIANC	World Association for Waterborne Transport Infrastructure
PMS	planned maintenance system
PORCP	National Places of Refuge Contingency Plan
PPA	Pacific Pilotage Authority
PPO	Pollution Prevention Officer
PPU	portable pilot units
PRPA	Prince Rupert Port Authority
PRPRCP	<i>Pacific Region Places of Refuge Contingency Plan</i>
PSC	Port State Control
QCDC	quick connect disconnect couplers
QRA	quantitative risk assessment
QRH	quick release hooks
QSCS	Quality System Certification Scheme
racon	radar beacon
RNC	raster navigational chart
RO	recognized organization (with respect to flag state affairs)
RO	response organization (with respect to spill response)
RT	radiotelephony
s	seconds
SAR	search and rescue
SIGTTO	Society of International Gas Tanker and Terminal Operators
SIRE	Ship Inspection Report Programme
SMPEP	Shipboard Marine Pollution Emergency Plan
SOLAS	<i>International Convention for the Safety of Life at Sea (SOLAS), 1974</i>
SOPEP	Shipboard Oil Pollution Emergency Plan
SOPF	Ship-source Oil Pollution Fund
SSL	ship-shore link
STCW	<i>International Convention on Training, Certification, and Watchkeeping for Seafarers</i>
SW	southwest

Abbreviation	Description
SWL	safe working load
t	metric tonne (equal to 1,000 kilograms)
TCMSS	Transport Canada Marine Safety and Security
TERMPOL	Technical Review Process of Marine Terminal Systems and Transshipment Sites
TOM	Terminal Operations Manual
Tp	peak wave period
TSB	Transportation Safety Board of Canada
UKC	underkeel clearance
US	United States
V-ATON	virtual aid to navigation
VDR	voyage data recorder
VHF	very high frequency
VLSFO	very low sulphur fuel oil
VTS	Vessel Traffic Services
WCMRC	Western Canada Marine Response Corporation

Preface

A Navigation Safety Assessment (NSA) is part of the Application. The NSA is an opportunity to review the Ksi Lisims LNG Project and determine whether additional resources (e.g., pilots), controls or infrastructure (e.g., navigational aids) are required and when they need to be in place. The NSA studies make-up Appendix E and findings inform Section 9 Malfunctions and Accidents and other sections (e.g., Section 7.11 Marine Use). Section 9.1.2 Planning provides a list and high-level description of the NSA studies. Additional navigation simulations will be completed before the start of operations and will be the subject of approval conditions.

1 Introduction

The *Terminal Plans and Cargo Transfer Report* is part of the Navigation Safety Assessment (NSA) for the Ksi Lisims LNG - Natural Gas Liquefaction and Marine Terminal Project (the Project). An overview of the Project, including the selected marine route for liquefied natural gas (LNG) carriers and natural gas liquid (NGL) product vessels, is provided in the *Marine Route Report* [1].

The *Terminal Plans and Cargo Transfer Report* describes the design of the marine terminal, including:

- The location of the marine terminal
- Wind data recorded near the Project Site (the Site)
- Wave data recorded at the Site
- Preliminary operating limits for the marine terminal
- Cargo transfer facilities for LNG carriers and NGL product vessels
- Berthing and mooring of LNG carriers and NGL product vessels

This report describes how the marine terminal berths and moorings can safely accommodate the design LNG carriers and NGL product vessels described in the *Vessel Specifications Report* [2].

2 Site Plans and Technical Data

2.1 Project Description

The LNG facility will consist of these elements:

- Two floating liquefaction, storage, and off-loading barge (FLNG) facilities that each include:
 - A spread mooring system (i.e., chains and anchors)
 - Berthing and mooring systems for LNG carriers and NGL product vessels
 - Loading arms to transfer LNG
 - Navigation aids
- Two access jetties and FLNG interface platforms
- Material off-loading facility (MOF), including:
 - Power barge berth(s)
 - Roll-on/roll-off (Ro-Ro) berth
 - Load-on/load-off (Lo-Lo) berth
 - Guide piles (adjacent to Ro-Ro berth)
- Floating temporary accommodation and personnel transfer dock

The conceptual layout of the LNG facility is shown in Figure 2.2 of the Detailed Project Description [3]. Bathymetry contour lines in Figure 2.2 are shown at 10 m intervals down to a maximum of 80 m depth. Seabed depths near the marine terminal are described in the *Marine Route Report* [1].

2.1.1 Floating and Fixed Structures

The FLNG hulls will be approximately 353 m long and 63 m wide, held in place with spread moorings. Each FLNG will be offset from its access jetty to allow for expected motions during the design metocean conditions and a design tsunami.

Permanently moored floating hulls for gas processing and liquid storage is a proven technology in use worldwide in varying ocean conditions. FLNG facilities (and the date they entered service) include:

- Petronas PFLNG1, Malaysia, 2017
- Golar, Hilli Episeyo, Cameroon, 2018
- Shell, Prelude, Australia, 2019
- Petronas, PFLNG2, Malaysia, 2020
- Eni, Coral South, Mozambique, 2022

FLNG projects nearshore have been proposed globally, and on Canada's west coast, but none are yet operating. The only FLNGs in operation are the FLNGs list above, located offshore, and exposed to more severe metocean conditions.

The FLNGs for the Project will use spread mooring technology like that used for offshore installations. However, the FLNGs for the Project will be exposed to much less severe metocean conditions relative to offshore FLNG installations. The FLNGs for the Project will be designed to local metocean conditions and tidal ranges.

Other marine terminal infrastructure includes:

- Two access jetties and FLNG interface platforms

- Feed gas supply, cooling system pipework, power cabling, and potable water to each FLNG
- Spread mooring system for each FLNG
- A MOF to offload equipment, materials, and modules during construction, and supplies during operations
- A personnel dock with access trestle, ramp, and floating platform

Access to the FLNGs will be by motion-compensating gangways supported on the interface platforms. The gangway systems will be self-deploying with no crane assistance. The gangways can operate at all tidal stages and range of expected FLNG motions.

Two modes of egress will be provided from the interface platforms. The primary egress route shall be by the access jetty, with the access route kept clear. The secondary egress will be by a safe-haven platform accessed by support vessels.

There will be no routine operations access between the LNG carriers or NGL product vessels and the FLNGs. LNG carrier or NGL product vessel crews will stay aboard the vessel while at berth. Any personnel transfers (e.g., pilots) will take place on the seaward side of the LNG carrier or NGL product vessel with personnel transferred to support vessels.

2.1.2 Tug Berth

Tugs will assist with berthing operations. Tug providers will be responsible for ensuring tugs are available. Tug providers will also be responsible for providing permanent tug facilities. Tug facilities at the Site will be limited to moorings for tugs on standby. Once the Project selects the tug operator, a suitable location for permanent tug facilities will be identified in consultation with the tug operator, Indigenous groups, and other stakeholders.

2.1.3 Shoreline and Scour Protection

The shoreline at the Site is sandy with rocky outcrops. Shoreline protection may be required to prevent erosion. Shoreline protection depends on the shoreline type (e.g., rocky, or sandy) and the marine terminal construction (e.g., open piled, or vertical quay wall). Where required, shoreline protection will be designed to withstand extreme events (i.e., a 1 in 100 year return period metocean event).

Scour can occur from the hydrodynamic forces caused by waves or propeller wash and can lead to undermining of structures if sufficient shoreline protection is not provided. Scour protection has been considered at the MOF area where berths are adjacent to vertical walls and there is a risk of scour from propeller wash. The water depth at the LNG carrier berths is sufficiently deep to avoid the need for scour protection.

2.1.4 Turning Basins and Manoeuvring Areas

Near the marine terminal, Portland Canal provides ample area for manoeuvring and turning LNG carriers with the assistance of berthing tugs. The available manoeuvring area exceeds the TERMPOL recommended minimum turning basin size of 2.5 times the overall length of the largest LNG carrier [4].

Inbound LNG carriers or NGL product vessels will normally berth starboard. The approach from Portland Canal to the berths requires LNG carriers or NGL product vessels to make a 180 degree tug-assisted turn, before berthing. This will allow for a straight departure leaving the marine terminal when loaded or in an emergency. Port-side berthing may be required depending on metocean conditions and pilot preference, in which case the arrival and departure approaches will be reversed.

2.1.5 Separation Between Berths and Navigation Channel

The marine terminal has two FLNGs each with one berth to load LNG carriers or NGL product vessels. The transverse clearance between the FLNGs and LNG carriers or NGL product vessel will be dictated by the fender design. The longitudinal clearance between the two berths is shown in the conceptual arrangement as approximately 100 metres. Clearance between berths will be confirmed during detailed project planning, which will include:

- Full mission bridge simulation (FMBS) and a joint British Columbia Coast Pilots Ltd. (BCCP) / Pacific Pilotage Authority (PPA) Navigational Risk Assessment (NRA)
- Design of the FLNG mooring system considering the range of FLNG and LNG carrier movements under operational metocean conditions, and the spread mooring line configuration for the FLNGs

Speed restrictions and passing distances for LNG carriers and other vessels in Portland Canal will be reviewed. The navigation channel adjacent the Site in Portland Canal is over 2.5 km wide. The marine terminal is partially recessed into a natural recess in the shoreline, meaning there is no conflict between the berths and passing vessel traffic.

Automatic identification system (AIS) data from 2019 and 2021 indicates vessel traffic passing the marine terminal totals 40 to 60 vessels per year (i.e., around one vessel per week). Approximately half the vessels recorded are cargo ships and the other half are tugs. Other small craft not required to carry AIS also transit Portland Canal. Further information on regional vessel traffic is in the *Marine Traffic Report* [5].

2.1.6 Anchorage Areas

Anchorage and holding areas are described in the *Marine Route Report* [1]. LNG carriers and NGL tankers will not anchor as part of normal operations. Delays will be managed through delaying departure from the marine terminal or timing of arrival at the pilot boarding station.

2.1.7 Underwater Installations

Canadian Hydrographic Services (CHS) charts for the Site and surrounding area in Portland Canal show no existing submarine cables or pipelines, and there are no other nearby developments.

The LNG facility will include these new underwater elements:

- The FLNGs will have spread mooring systems (i.e., chains and anchors)
- Feed gas will enter the Site by a submerged gas pipeline oriented approximately east-southeast across Portland Canal
- An incoming subsea power cable will be oriented approximately northeast across Portland Canal. A fibre optic communications connection along the subsea power cable is also being considered

The new underwater elements will not influence navigational safety and will be in depths that exceed the draft of the largest design vessels.

The gas pipeline and subsea power cable are independent projects, subject to their own approval and permitting processes.

2.1.8 Dredging and Fill Operations

The marine terminal design is not forecast to include dredging.

The MOF is expected to require fill to construct the marginal wharves. The nature, extent and source of the fill material will be established during detailed project planning but is not expected to include marine-sourced fill.

2.1.9 Site Wind Conditions

A metocean study of the conditions at Wil Milit has been completed [6]. The metocean study included deploying wind, current and wave monitoring equipment near the Site for six months, including the winter storm season, from August 2021 to February 2022. The measured winds at Wil Milit are low, not exceeding 9.3 m/s over the six-month period. The low values are believed to be due to the protection provided by the topography surrounding Wil Milit.

The metocean study included analysis of wind readings at Grey Islet, located east of the Dundas Island group at the northern end of Chatham Sound, near Main Passage. The location of Grey Islet is aligned with the longitudinal axis of Portland Inlet. Grey Islet wind statistics can characterize the winds in Chatham Sound and winds in Portland Inlet and Portland Canal (e.g., wind in northeast and southwest directions). The wind roses for Wil Milit and Grey Islet are shown in Figure 1. Further details are in the *Marine Route Report* [1].

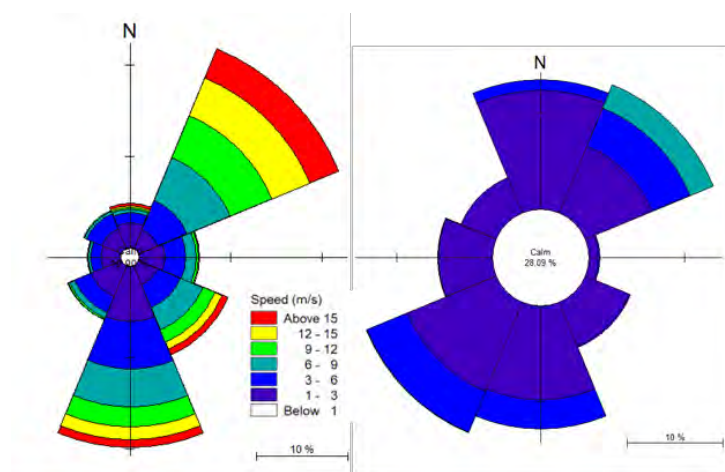

Figure 1 - Wind Rose for Grey Islet, 1994-2022 (left); and Wil Milit, 2021-2022 (right) [6]

2.1.10 Site Wave Conditions

The metocean study recorded wave heights near the Site. A time series of recorded significant wave heights near the Site is in Figure 2. The highest wave recorded was 0.76 m during a northerly storm in the first week of January 2022. For other storms exceeding 15.0 m/s wind speed at Grey Islet, the wave heights were less than 0.7 m at the Site. The wave rose in Figure 3 shows the dominant waves at the Site are from the north and southeast directions.

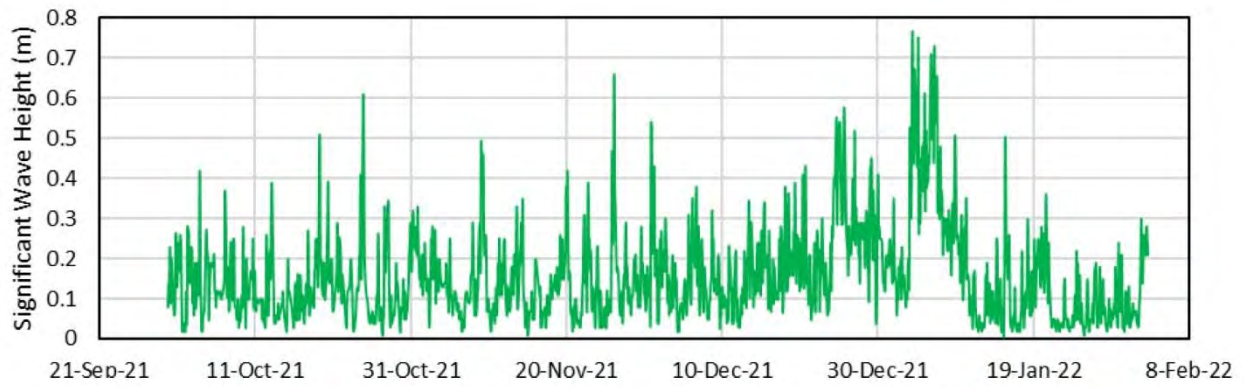

Figure 2 - Timeseries of significant wave height near the Site [6]

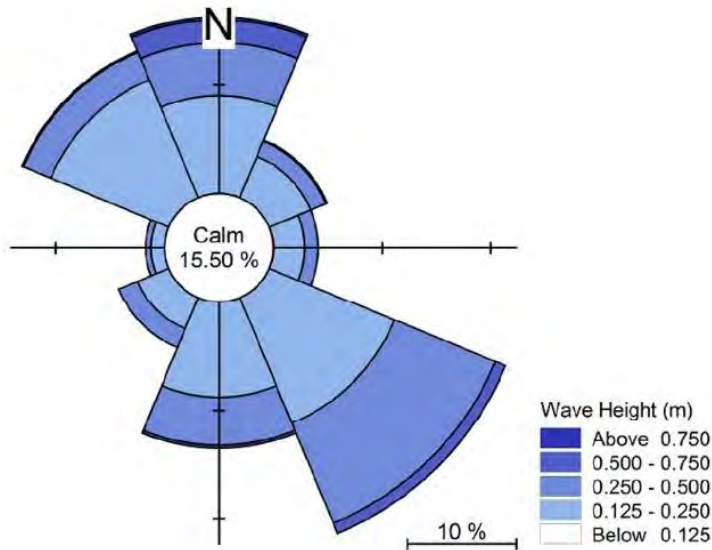

Figure 3 - Significant wave height near the Site [6]

2.1.11 Tides and Currents

Tides at the Site will be similar to tides at Gingolx, approximately 15 km to the east of the Site. Tides for Gingolx are in Table 1 and are referenced from Prince Rupert using Volume 7 of the Canadian Tide and Current Tables [7].

Table 1 – Forecast tidal levels at the Site

Tidal Plane	Tide Level (m Chart Datum)
Extreme Recorded Highest High Water (EHHW)	8.0
Higher High Water Level Large Tide (HHWLLT)	7.4
Higher High Water Level Mean Tide (HHWLMT)	6.2
Mean Water Level or, Mean Sea Level (MWL)	3.8
Lower Low Water Level, Mean Tide (LLWLMT)	1.3
Lower Low Water Level Large Tide (LLWLLT)	0.0
Extreme Recorded Lowest Low Water (ELLW)	-0.4

The metocean study measured nearshore currents near the Site using a A-TRDI 600 kHz WorkHorse Acoustic Doppler Current Profiler (ADCP) in 22 m deep water. Current statistics for three depths are provided in Table 2. Currents exceed 50 cm/s for 8% of the time with a maximum recorded current of approximately 91 cm/s. The depth averaged current is estimated to be 22 cm/s.

Table 2 - Current speed (cm/s) near the Site [6]

Location	Speed (cm/s)					
	Min	Mean	95%	99%	std	Max
5.8 m below surface	0.1	23.1	55.8	70.6	16.7	90.8
10.6 m below surface	0.1	22.4	55.5	68.7	16.7	90.2
18.6 m below surface	0.1	20.3	49.4	60.4	14.9	78.9

Construction of the marine terminal is not anticipated to have any material effect on the tides and currents for the Site.

2.2 Terminal Design, Operating and Safety Parameters

2.2.1 Codes, Standards, and Guidelines

Design of the facilities will conform to the applicable sections of the codes, standards, and guidelines in Appendix A.

2.2.2 Design Vessels

Design LNG carriers range from approximately 140,000 m³ to of 217,000 m³ capacity. LNG carriers calling at the marine terminal are not forecast to exceed approximately 180,000 m³ capacity. The LNG facility is being designed for LNG carriers up to 217,000 m³ capacity as a future provision. Design NGL product vessels range from approximately 5,000 to 30,000 dwt capacity. Parameters for the design LNG carriers and NGL product vessels are in the *Vessel Specification Report* [2].

2.2.3 Design Loads

The FLNG hull design will meet the following criteria.

2.2.3.1 FLNG Load Assessment

The FLNG hulls will be assessed for metocean conditions at the Site. FLNG hull stability will be to the rules of the nominated Classification Society (American Bureau of Shipping [ABS]), during tow and at the Site.

The Site is free of sea ice, so the FLNG hulls need not be designed for solid ice impact loads.

The FLNGs are expected to be designed to the following metocean conditions and return periods:

- Operating conditions – 1 year return period (target availability of 94%)
- Extreme Condition – 100-year return period
- Survival condition – 10,000-year return period

2.2.3.2 Wind Loading

Wind loads for the LNG facility will be calculated under applicable design codes considering the design wind speeds, directions, and gust factors. See Appendix A.

2.2.3.3 Waves and Currents

Wave and current loads for the marine terminal will be calculated under applicable international design codes. See Appendix A.

2.2.3.4 Mooring and Berth Loads

Loads on the FLNGs from mooring and berthing of LNG carriers will be determined for:

- Reactions from fenders for both normal and abnormal berthing conditions
- Design mooring loads
- Environmental loads up to and exceeding the operating limits in Section 4.2

2.2.3.5 Seismic Loads

Earthquake loads and their effect will be calculated under applicable Canadian and international design codes. See Appendix A.

2.2.3.6 Tsunami Loads

A preliminary analysis of tsunami risk at the Site is based on an assessment at the Village of Gingolx. This assessment indicates that the tsunami event generated by the Great Alaska Earthquake of September 1964, with a magnitude of 9.2 and a return period of this event is 700 years, results in a 1.5 m tsunami wave (i.e., crest height above the local tide) with a current speed of 1.5 m/s. Tsunamis, including landslide-generated tsunamis, will be further assessed during detailed project planning.

2.2.4 FLNG and LNG Carrier Mooring Analysis

The FLNGs will be assessed for conditions with and without LNG carriers and NGL product vessels alongside. The FLNGs will be evaluated for safe working loads (working load limit) for the mooring chains and acceptable FLNG motions over the full range of design metocean conditions, including extreme cases exceeding operating limits for the berths. The working load limits for mooring lines, pneumatic fenders, and acceptable motions for the LNG carriers and NGL product vessels will also be assessed.

Other factors to be assessed include:

- Ensuring adequate underkeel clearance when FLNG storage is full
- Checking clearances between the FLNGs and fixed structures
- Checking to ensure there is no interaction of the FLNG mooring chains with the hull of the LNG carriers or NGL product vessels at berth

2.2.5 Marine Terminal Identification and Lighting

The marine terminal navigation aids may include lighted buoys, fixed berth lights and sector(s). The locations, and detailed specifications will be developed during detailed project planning.

Soft lighting will be mounted on the outer vertical face of the FLNGs where it will be visible from seaward but will not interfere with mooring line deployment. Soft lighting will be such that it is not obscured by a buildup of ice or snow.

2.2.6 Pilot Access

There will be no routine operational access between the FLNGs and LNG carriers or NGL product vessels at berth. Transfer of personnel will be to support vessels on the seaward side of the LNG carrier or NGL product vessel.

2.2.7 Operating Parameters

Berthing, mooring and forecast operating limits for the marine terminal are described in Section 4.

3 Cargo Transfer Systems

3.1 Storage and Loading System

The Project will receive feed gas from a dedicated pipeline. The gas received at the Site will be treated on the FLNGs. The Project forecasts an annual production capacity of 12 mtpa. Gas reception will be onshore. The feed gas pre-treatment units and liquefaction/refrigeration units will be installed on the FLNGs with heavy hydrocarbon removal units and all ancillary units.

The FLNGs will be self-sufficient requiring only electric power, cooling water, and potable water. Electrical power for the FLNGs, and all other onshore facilities, will be from the power grid or floating power generation barges. An intermediate cooling medium (water) will be provided to each FLNG and return to the onshore cooling system. Each FLNG is to be designed for an LNG production capacity of 6 mtpa. Each unit will be designed considering the design gas composition at the design ambient air temperature and the design cooling water temperature. Each FLNG will store 245,000 m³ of LNG product.

3.2 Process Description

The LNG storage and loading systems includes these main elements:

- LNG storage tanks
- LNG loading and circulation system
- Boil off gas (BOG) recovery system

The storage and loading system onboard the FLNG at the marine terminal will have two principal operational modes: "holding" and "loading":

- **Holding Mode** - Between loading operations, the FLNG storage tanks receive rundown LNG from the LNG trains. BOG generated will be managed by the BOG management system
- **Loading Mode** - In the loading mode, LNG is pumped from the LNG storage tanks and loaded into LNG carriers. BOG displaced from LNG carrier tanks is returned to the FLNG storage tanks. BOG generated during the loading is managed on the FLNG by the BOG management system

BOG generated in both the holding and loading modes is returned to the BOG management system where it is recompressed and re-liquefied.

3.2.1 LNG Loading and Circulation

The loading and circulation system on each FLNG will allow loading of one LNG carrier. The LNG loading system will load spherical tank and membrane tank LNG carriers. LNG carriers are all top loading, but spherical LNG carriers have a top inlet significantly higher than those of membrane tank carriers, and thus require a higher manifold pressure for loading.

The vapour return lines, the BOG handling system, and the flare system (only for extreme unplanned events) will accommodate both spherical tank and membrane tank LNG carriers. Spherical tank type LNG carriers have a much greater mass of metal in contact with the LNG than membrane tank type carriers. Therefore, it takes longer to cool spherical tanks and more BOG is generated.

The FLNG loading arm configuration will include three liquid loading arms and one vapour return arm. One of the liquid loading arms will be a hybrid loading arm for both liquid loading and vapour return. The loading arms are to be fitted with quick connect disconnect couplers (QCDC) and an emergency release system (ERS), so the arms can be disconnected if an LNG carrier needs to depart the berth quickly or moves outside the tolerances of the loading arms.

The FLNG and the LNG carrier will be connected by a ship-shore link (SSL). The SSL ensures that if an emergency stop is operated on either the LNG carrier or the FLNG, cargo loading will be stopped, and the isolation valves moved into a safe position.

The FLNG storage tanks will contain submerged pumps for loading and pre-cooling lines. In the holding mode, one (or more) pump may circulate LNG in the loading lines to cool the loading lines.

Loading is expected to include these stages:

- **Pre-transfer** – Includes meeting to agree on the operational parameters, communication protocols and other aspects of the loading operation including custody transfer, pre-gauging, and calculation
- **Connection** – Includes connection of the arms, SSL, and a verification test of the same, completion of the pre-operation checklists, and a warm test of the emergency shutdown (ESD) system
- **Start of loading** - LNG is loaded at a reduced rate for cooldown of the loading arms and LNG carrier tanks followed by a cold test of the transfer ESD system. This phase lasts approximately one hour
- **Cargo ramp-up** - Over the next half-hour, additional loading pumps are brought online, and the loading rate increases to the design LNG loading rate
- **Loading** – LNG loading continues at full rate. This will take approximately 18 hours for the largest design LNG carrier
- **End of loading** - Towards the end of loading, the LNG loading rate is reduced for topping off the LNG carrier tanks one at a time. Over a period of approximately one-half to one hour, loading stops
- **Purging and disconnection** - On completion of loading, the LNG remaining in the loading arms is drained into the LNG carrier and FLNG. The draining of a loading arm will be completed in five to ten minutes. The subsequent purging of the loading arm with nitrogen will be completed in approximately five minutes. The loading arms at the jetty will be drained and purged one after the other
- **Post-disconnection** – After loading, checklists are completed, including custody transfer, gauging and calculation, review of the loading operation and preparation for departure

3.2.2 Loading Arm Design

Each FLNG will utilize mechanical loading arms to transfer LNG to the LNG carriers and to handle return vapour from the LNG carriers. LNG carriers will arrive at the marine terminal with a heel of LNG and tanks at cryogenic temperatures (“warm” LNG carriers will not be accepted). The LNG facility design will allow loading to occur simultaneously at both FLNGs, although this is not forecast for normal operations.

The LNG loading system on each FLNG will be designed for these parameters:

- LNG loading rate of up to 12,000 m³/h
- Four 16” in diameter loading arms with QCDC, including:
 - Two LNG loading arms
 - One LNG vapour return arm
 - One LNG hybrid arm for LNG loading or vapour return

NGL product vessels will be loaded with condensate using hoses and hose-handling equipment aboard the FLNGs.

3.2.3 Utilities in Storage and Loading System

The utilities required for the LNG storage and loading system are summarized below and will be confirmed during detailed project planning.

- **Process Cooling** - an onshore cooling system shall be sized to support the FLNG process design. The intermediate cooling medium is water
- **Process Heating** - heating for the regen gas heater and regenerator reboiler on each FLNG will be by a closed loop heating medium (HM) system. The heating medium will be a synthetic, liquid-phase heat transfer fluid
- **Fuel Gas Systems** - feed gas will be used as fuel gas for the power generation barges (should power generation barges be required). FLNG fuel gas make-up will be provided by feed gas with onboard fuel gas treatment. Fuel gas is anticipated to be required on the FLNGs for the HM fired heaters and the thermal oxidizers
- **Diesel Fuel Systems** - diesel will be used as fuel for the emergency diesel generators (EDGs) and the firewater pumps. The EDGs shall have a diesel storage capacity for essential loads over a 14-day period. Storage and distribution of diesel will be confirmed during detailed project planning
- **Air Systems** - air will be generated on the FLNGs for instrument and plant air services
- **Nitrogen Systems** - nitrogen will be generated on the FLNGs for normal inert gas requirements such as purging of loading arms
- **Water Systems** - freshwater will be generated, treated, and stored at the onshore facility. Freshwater will supply the potable water system, and the utility water system
- **Effluent Systems** - waste discharges to water and air will be treated to regulatory requirements

3.2.4 Loading System Emergency Shutdown

A two-stage ESD system on each FLNG will be linked to the LNG carrier's ESD system. The first stage shutdown will close the isolation valves in the loading lines and trip the loading pumps, stopping all transfer of LNG when operating parameters exceed pre-set levels. The system can be operated manually from strategically located push buttons.

The second stage shutdown will activate the ERS in the loading arms if an LNG carrier needs to depart the berth quickly or moves outside the tolerances of the loading arms. If surge pressures are generated in the rapid closure of the ESD / ERS valves, protection will be provided by specifying an appropriate pressure rating for the loading system or surge protection.

3.2.5 Ship Stability During Loading

The marine terminal will not be restricted to specific LNG carriers or NGL product vessels, so vessel-specific stability assessments are not available. There are several procedural controls to ensure LNG carriers and NGL product vessels meet stability requirements.

The *International Convention for the Safety of Life at Sea (SOLAS)* requires LNG carriers and NGL product vessels to have an approved loading and stability manual on board. The data from the manuals is generally incorporated into a class-approved stability computer onboard each LNG carrier or NGL product vessel to facilitate calculation of stability, draft, and hull stresses.

The Project will have an acceptance program for LNG carriers and NGL product vessels. The acceptance program will confirm that LNG carriers and NGL product vessels have the required certifications and have completed a satisfactory Ship Inspection Report Programme (SIRE) inspection in the previous 12 months. Documentation subject to in-person inspection as part of the SIRE programme, includes the vessel's intact and damage stability booklet. Further details of the vessel acceptance program are provided in the *Vessel Specification Report* [2].

4 Berth Procedures and Provisions

4.1 Navigation Simulation

The Project has completed a desktop simulation of the selected marine route as described in the *Marine Route Report* [1]. Further FMBS and the NRA will confirm the berth arrangement, approach details and the operational procedures for tug assistance. Tests will be undertaken for a range of normal and limiting operational conditions. The FMBS and NRA will be completed at least six months before the start of operations.

4.2 Maximum Operating Parameters

Marine terminal operations will be monitored in real-time in a control room. The marine terminal design includes a two-stage ESD system that would stop the flow of LNG should parameter exceed operational limits. The ESD system will operate electronically. The FLNGs will also have controls for manual shutdown. The FLNG design will also ensure redundancy and isolation capability, allowing loading to be completed if a loading arm is offline for maintenance (maintenance activity would not occur during loading).

Sea ice is not present at the Site. Wave and current conditions at the Site are not forecast to limit operations. Wind speeds may limit operations. Operating limits have not yet been set for the LNG facility and will be confirmed in detailed project planning, the FMBS and NRA. The marine terminal operating limits are expected to be similar to other LNG terminals as indicated in Table 3.

Table 3 – Preliminary operating limits

Sustained Wind Speed	Operational Conditions
Wind speed < (30 to 35 kts)	Marine terminal open for all operations.
Windspeed = (30 to 35 kts)	Cargo transfer to terminate, cargo arms to be drains, purged, disconnected, and retracted into their locked position. Tugs on standby.
Wind speed > (30 to 35 kts)	LNG carrier may remain at berth, additional mooring lines may be deployed. LNG carrier must be able to unberth and sail clear of marine terminal with tug assistance.

Marine terminal operations are informed by weather forecasts and real-time weather monitoring. Further details of these systems are provided in the *Marine Route Report* [1].

Operational guidance will be developed to address seismic events, tsunamis, and other extreme events.

4.3 Monitoring Systems

Monitoring systems at the marine terminal will include the systems described below.

4.3.1 Quick Release Hooks and Mooring Load Monitoring System

Quick release hooks provide a safe and efficient means of securing LNG carriers and NGL product vessels. In an emergency they allow for the rapid release of mooring lines, even while under full tension. Each

multi-hook unit typically includes an integrated capstan used to haul in the mooring line before it is placed on its corresponding hook. Once a mooring line is attached to a hook, the line is tensioned by the winch gear on the LNG carriers or NGL product vessels.

Mooring lines can be monitored from the marine terminal control room and adjusted to achieve balanced mooring loads. The monitoring system can sound an alarm to indicate a mooring line is overloaded. An important safety feature of the quick release hooks is a remote release system, which allows mooring lines to be released from the marine terminal control room. This removes the need for marine terminal personnel to be on the berth structures near tensioned mooring lines.

4.3.2 Docking Assist System

The marine terminal will install a docking assist system (DAS) to provide a visual display of the approach angle and berthing velocities relative to the marine terminal berth structures. The DAS provides pilots with information to assist with the safe berthing of the LNG carriers and NGL product vessels. The pilots will also carry portable pilot units (PPU) to assist with navigation and berthing operations.

4.3.3 Metocean Monitoring System

Monitoring equipment will assist the LNG carrier captain, pilot, and attending tugs by transmitting real-time wind, wave, current, and tide information.

4.4 Berthing Strategy

LNG carriers and NGL product vessels will be brought alongside the FLNGs with support from berthing tugs and a pilot on board. The forecast design berthing parameters are listed below:

- 0.15 m/s design approach velocity perpendicular to the berth face
- 10 degree design approach angle

Berthing procedures will be confirmed during detailed project planning, the FMBS and NRA.

4.5 Mooring Strategy

The Project will have an acceptance program for LNG carriers and NGL product vessels. Further details of the vessel acceptance program is in the *Vessel Specifications Report* [2]. LNG carriers and NGL product vessels will be checked to ensure they are compatible with the marine terminal mooring arrangement.

LNG carriers and NGL product vessels are forecast to moor directly to the FLNGs (i.e., no separate fixed mooring dolphins are required). The FLNG vessels will be fitted with quick release hooks (QRH) for use with the LNG carrier and NGL product vessel mooring lines and winches.

Figure 4 shows the approximate locations of the QRH on the FLNG. The exact locations and types of mooring equipment will be confirmed during detail project planning.

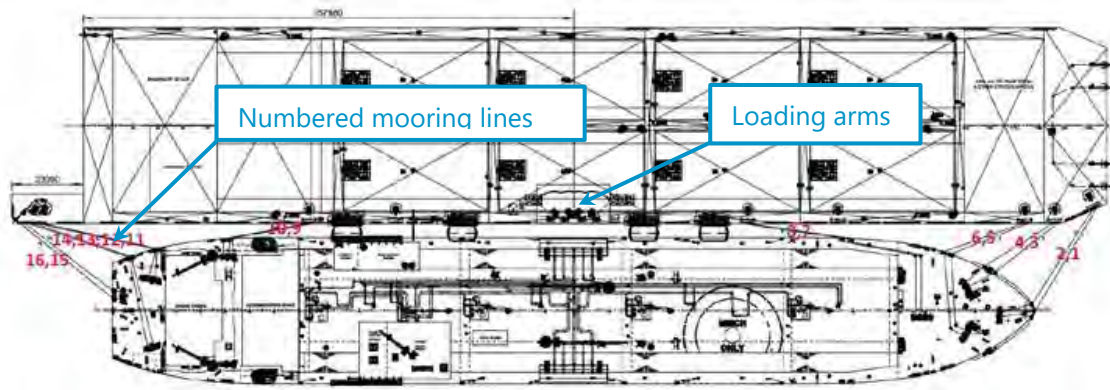

Figure 4 - Mooring points on the FLNG

4.6 Safety and Security Plans

4.6.1 Safety Plans

A formal safety assessment of the cargo transfer system and ship-shore interface will be undertaken at least six months before the marine terminal commences operations.

4.6.2 Security Plans

A Terminal Operations Manual (TOM) will inform and guide the crews of LNG carriers and NGL product vessels calling at the terminal. An outline of the TOM is provided in the *Terminal Operations Manual Report* [8]. The TOM will include a section on marine terminal security and safety zones. The TOM will comply with the Marine Transportation Security Regulations [9].

References

- [1] Westmar Advisors Inc., "Marine Route," 1220197_P01_22_RPT_0001, 2023.
- [2] Westmar Advisors Inc., "Vessel Specifications," 1220197-P01-24-RPT-0001, 2023.
- [3] Ksi Lisims LNG, "Ksi Lisims LNG Detailed Project Description," BC Environmental Assessment Office, 2022, p. 680. Accessed: Aug. 15, 2022. [Online]. Available: <https://www.projects.eao.gov.bc.ca/p/60edc23bc69c5e0023a12539/project-details>
- [4] Transport Canada, "TERMPOL Review Process 2001." 2001.
- [5] Westmar Advisors Inc., "Marine Traffic," 1220197-P01-21-RPT-0001, 2023.
- [6] Westmar Advisors Inc., "Metocean Study," 1210142-P02-RPT-0001, May 2022.
- [7] Canadian Hydrographic Service, "Tide and Current Tables: Queen Charlotte Sound to Dixon Entrance." Department of Fisheries and Oceans, 2022. Accessed: Aug. 19, 2022. [Online]. Available: <https://waves-vagues.dfo-mpo.gc.ca/library-bibliotheque/chs-shc-tct-tmc-vol7-2022-41052584.pdf>
- [8] Westmar Advisors Inc., "Terminal Operations Manual," 1220197-P01-27-RPT-0001, 2023.
- [9] *SOR/2004-144 | Marine Transportation Security Regulations*. CanLII. Accessed: Jul. 26, 2023. [Online]. Available: <https://www.canlii.org/en/ca/laws/regu/sor-2004-144/112853/sor-2004-144.html>

Appendix A

Codes, Standards and Guidelines



A Codes, Standards and Guidelines

Design of the facilities will conform to the applicable sections of the following codes, standards, and guidelines:

Marine Terminal Design

- ABS Rules for Building and Classing Single Point Moorings, American Bureau of Shipping
- ABS Positioning of Mooring Systems, American Bureau of Shipping
- API RP 2A-WSD-14 - Planning, Designing and Constructing Fixed Offshore Platforms
- ASCE 61-14 - Seismic Design of Piers and Wharves
- BS 6349-1-1 - Maritime Works - Part 1-1: General - Code of Practice for Planning and Design for Operations
- BS 6349-1-2 - Maritime Works - Part 1-2: General - Code of Practice for Assessment of Actions
- BS 6349-1-3 - Maritime Works - Part 1-3: General - Code of Practice for Geotechnical Design
- BS 6349-2 - Maritime Works - Part 2 Code of Practice for the Design of Quay Walls, Jetties and Dolphins
- BS 6349-4 - Maritime Works - Part 4 Code of Practice for Design of Fendering and Mooring Systems
- BS 6349: 6 - Maritime Works: Part 6: Design of Inshore Moorings and Floating Structures, British Standard Institution
- CSA SPE-276.1:20 - Design Requirements for Marine Structures Associated with LNG Facilities (DRMS)
- CSA Z276:22 - Liquefied natural gas (LNG) - Production, storage, and handling
- CSA S6-14 - Canadian Highway Bridge Design Code
- CSA Z276.2 "Design requirements for near-shoreline floating liquefied natural gas (FLNG) facilities
- DNV-RP-C205 - Recommendation Practice DNV-RP-C205: Environmental Conditions and Environmental Loads, Det Norske Veritas
- DNV-GL - Guideline for Moorings - Rules and Standards, 0032/ND
- EN ISO 20257 - Installation and equipment for liquefied natural gas - Design of floating LNG installations
- EN 1474 - Installation and equipment for liquefied natural gas. Design and testing of marine transfer systems Design and testing of transfer hoses
- IMO SOLAS publications
- IMO MARPOL publications
- MOTEMS (Marine Oil Terminal Engineering and Maintenance Standards), California Building Code, Chapter 31F
- Oil Companies International Marine Forum (OCIMF) guidelines
- OCIMF - Guidelines and Recommendations for the Safe Mooring of Large Ships at Piers and Sea Islands
- OCIMF - Effective Mooring
- OCIMF - Mooring Equipment Guidelines
- OCIMF - Contingency Planning and Crew Response Guide for Gas Carrier Damage at Sea and in Port Approaches
- OCIMF - A Guide to Contingency Planning for the Gas Carrier Alongside and Within Port Limits

- OCIMF - Guidelines and Recommendation for the Safe Mooring of Large Ships at Piers and Sea Islands, Oil Companies International Marine Forum
- OCIMF - Recommendations for Oil Tanker Manifolds & Associated Equipment, Oil Companies International Marine Forum
- OCIMF - Ship to Ship Transfer Guide for Petroleum, Chemicals and Liquefied Gases, Oil Companies International Marine Forum
- OCIMF - Mooring Equipment Guidelines (MEG)
- PIANC - MarCom WG 117 - Use of hydro/meteo information to optimize safe ports access
- PIANC - MarCom WG 153B - Recommendations for the Design and Assessment of Marine Oil, Gas and Petrochemical Terminals
- PIANC - MarCom WG 116 - Safety aspects of berthing operations of oil and gas tankers
- PIANC - MarCom WG 24 - Criteria for movements of moored ships in harbours – A practical guide
- PIANC - MarCom WG 33 - Guidelines for the Design of Fenders Systems: 2002
- PIANC - MarCom WG 34 - Seismic Design Guidelines for port structures
- Recommended Practice 2SK, Design and Analysis of Station Keeping Systems for Floating Structures, American Petroleum Institute
- ROM 3.1-99 - Designing the Maritime Configuration of Ports, Approach Channels and Flotation Areas, Santander: Gráficos Calima
- SIGTTO - LNG Operations in Port Areas: Essential best practices for the Industry
- SIGTTO - Site Selection and Design for LNG Ports and Jetties (Information Paper No.14)
- SIGTTO/OCIMF - Contingency Planning for Gas Carrier Alongside and Within Port Limits
- SIGTTO - Guidance on Gas Carrier and Terminal Gangway Interface, 2021
- SIGTTO - Floating LNG Installations, 2021
- SIGTTO – Emergency shutdown (ESD) Systems, 2021
- SIGTTO - Recommendations for Liquefied Gas Carrier Manifolds, 2018
- SIGTTO - Guidelines for the Alleviation of Excessive Surge Pressures on ESD for Liquefied Gas Transfer Systems, 2018
- SIGTTO - LNG Emergency Release Systems - Recommendations, Guidelines and Best Practices, 2017
- SIGTTO - Support Craft at Liquefied Gas Facilities. Principles of Emergency Response and Protection – Onshore, 2016
- SIGTTO - LNG Marine Loading Arms and Manifold Draining, Purging and Disconnection Procedure, 2017
- The Nautical Institute - Tug Use in Port - A Practical Guide
- Transport Canada publications

Navigation

- International Association of Lighthouse Authorities (IALA) Aids to Navigation Guide (Navguide) 4th Edition
- PIANC - MarCom WG 121 - Harbour Approach Channels Design Guidelines

Structural Design

- AASHTO American Association of State Highway and Transportation Officials
- ACI 350 - Code Requirements for Environmental Engineering Concrete Structures

- ACI 376 - Code Requirements for Design and Construction of Concrete Structures for the Containment of Refrigerated Liquefied Gases and Commentary
- American National Standards Institute (ANSI) as referred in the BC Building Code
- ASHRAE Handbook - Fundamentals
- BC Fire Code
- BC Plumbing Code
- BC Occupational Health and Safety Act and Regulation
- Canadian Foundation Engineering Manual (CFEM)
- Canadian Geotechnical Society - Canadian Foundation Engineering Manual 2006
- CSA S16 - Design of Steel Structures
- CSA A23.3 - Design of Concrete Structures
- International Building Code (IBC)
- National Research Council Canada (NRCC)
- National Energy Code of Canada for Buildings (NECB)

1 **ATTACHMENT E.6 CONTINGENCY PLANNING AND HAZARDOUS**
2 **AND NOXIOUS SUBSTANCES**

Ksi Lisims LNG
Navigation Safety Assessment

Contingency Planning and Hazardous and Noxious Substances

11 October 2023



Disclaimer

This report is not intended to stand alone without reference to the instructions given to Westmar by Ksi Lisims LNG, communications between Westmar and Ksi Lisims LNG, and any other reports, proposals or documents prepared by Westmar for Ksi Lisims LNG under the governing contract between Westmar and Ksi Lisims LNG. To understand the suggestions, recommendations and opinions expressed herein, reference must be made to all relevant documents and communications.

This report has been prepared only for the purposes that are set out in the governing contract between Westmar and Ksi Lisims LNG. The findings, recommendations, suggestions and or opinions expressed in this report are only applicable to the purposes for which the report is expressly provided, and then only to the extent that there has been no material alteration to or variation from the information provided or available to Westmar.

The information and opinions expressed in this report are for the sole use and benefit of Ksi Lisims LNG. No other party may use or rely upon the report or any portion thereof without Westmar's prior written consent, and such use shall be on terms and conditions as Westmar expressly approves. Ownership in and copyright for the contents of the report belong to Westmar. Any use which a third party makes of the report is the sole risk and responsibility of such third party. Westmar accepts no responsibility whatsoever for loss or damages suffered by any third party in relation to use of this report.

Company Details

Westmar Advisors Inc.
700 - 1901 Rosser Avenue
Burnaby, BC, V5C 6R6

T 604 770 4787

info@westmaradvisors.com

Table of Contents

Abbreviations	v
Preface	x
1 Introduction	1
1.1 Project Background	1
1.2 Vessel Acceptance Program	2
2 International Requirements	3
2.1 SOLAS	3
2.1.1 ISM Code	4
2.2 MARPOL	4
2.2.1 National Contact Points	5
2.3 STCW Convention and Code	6
2.4 International Best Practices	6
2.5 Incident Command System	6
2.6 OPRC-HNS Protocol	7
3 Canada’s Preparedness and Response Regime	8
3.1.1 Transport Canada	8
3.1.2 Canadian Coast Guard	8
3.2 Other Agencies	8
3.3 Response Organizations	9
3.3.1 Western Canada Marine Response Corporation	9
3.3.2 Planning Standards	10
3.3.3 Certification	11
3.4 Places of Refuge	11
4 Considerations for Response Planning	12
4.1 LNG Properties	12
4.2 Condensate	13
5 Marine Terminal Contingency Plan	14
5.1 Nisga’a Lisims Government	15
6 Liability and Compensation	16
6.1 Marine Liability Act	16
6.2 Ship-Source Oil Pollution Fund	16
6.3 International Funds	16
6.3.1 Bunkers Convention	16
6.3.2 2010 HNS Convention	16
References	18

Appendices

Appendix A Contingency Planning Documents

List of Tables

Table 1 - Response organization exercises and frequency..... 11

List of Figures

Figure 1 - WCMRC network [23] 10

Abbreviations

Abbreviation	Description
°C	degrees Celsius
ABS	American Bureau of Shipping
ADCP	acoustic doppler current profiler
AIS	automatic identification system
AIS ATON	automatic identification system aid to navigation
AK	Alaska
ANSI	American National Standards Institute
ARI	average recurrence interval
ATON	aids to navigation
BC	British Columbia
BCCP	British Columbia Coast Pilots Ltd.
BCER	BC Energy Regulator
BNWAS	bridge navigational watch alarm system
BOG	boil off gas
BV	Bureau Veritas
CCG	Canadian Coast Guard
CHS	Canadian Hydrographic Services
CMB	continuous marine broadcast
CPAs	Compulsory Pilotage Areas
DAS	docking assist system
deg	degree
DFO	Fisheries and Oceans Canada
DNV	Det Norske Veritas
dwt	deadweight tonnage
EA	environmental assessment
ECCC	Environment and Climate Change Canada
ECDIS	electronic chart display and information system
EDG	emergency diesel generators
EEBD	Emergency Escape Breathing Device
EMSA	enhanced maritime situation awareness
ENC	electronic navigational chart
EOC	Emergency Operations Centre
EPIRB	emergency position-indicating radio beacon
ERS	emergency release system

Abbreviation	Description
ESD	emergency shut down
ETA	estimated time of arrival
EU	environmental unit
FEED	front-end engineering design
FFA	fire fighting appliances
FLNG	floating liquefaction, storage, and off-loading barge
FMBS	full mission bridge simulation
FMO	Federal Monitoring Officer
FSA	Formal Safety Assessment
FSRU	floating storage and regassification units
GMDSS	Global Maritime Distress, and Safety System
GNSS	Global Navigation Satellite System
GTT	Gaztransport and Technigaz
HFO	heavy fuel oil
HNS	hazardous and noxious substances
Hs	significant wave height
IACS	International Association of Classification Societies
IALA	International Association of Marine Aids to Navigation and Lighthouse Authorities
ICS	Incident Command System
IGC Code	<i>International Code for the Construction and Equipment of Ships Carrying Liquefied Gases in Bulk</i>
ILO	International Labour Organization
IMO	International Maritime Organization
ISGOTT	<i>International Safety Guide for Oil Tankers and Terminals</i>
ISM	International Safety Management
ISPS	<i>International Ship and Port Facility Security Code</i>
kHz	kilohertz
km	kilometre
kn	knot
LBP	length between perpendiculars
LFL	lower flammability limit
LLWLT	lower, low water, large tide
LNG	liquefied natural gas
LOA	length overall
LOS	level of service
LPG	liquefied petroleum gas
LR	Lloyd's Register

Abbreviation	Description
LSA	life-saving appliances
LSIR	location specific individual risk
LTA	line throwing appliance
m	metre
m	metres per second
m ²	square metres
m ³	cubic metres
m ³	cubic metres
m ³ / hour	cubic metres per hour
MARPOL	<i>International Convention for the Prevention of Pollution of Ships</i>
MCTS	Marine Communications and Traffic Services
MDO	marine diesel oil
MGO	marine gas oil
MOF	material off-loading facility
MOU	Memorandum of Understanding
MSI	Marine Safety Inspectors
MSOC	Marine Security Operations Centre
MTBE	methyl tertiary butyl ether
mtpa	million tonnes per annum
NASP	National Surveillance Aerial Program
NAVTEX	Narrow Band Direct Printing Telegraphy
NAVWARN	navigational warnings
NGL	natural gas liquid
NK	Nippon Kaiji Kyokai
NLG	Nisga'a Lisims Government
NLS	Noxious Liquid Substances
NOA	notice of arrival
North Coast	north coast of British Columbia
NOTMAR	Notices to Mariners
NRA	BCCP / PPA Navigational Risk Assessment
NSA	navigation safety assessment
NW	northwest
OCIMF	Oil Companies International Marine Forum
ODAS	ocean data acquisition system
OGAA	<i>Oil and Gas Activities Act</i>
OPP	Oceans Protection Plan

Abbreviation	Description
OPRC	<i>International Convention on Oil Pollution Preparedness, Response and Co-operation</i>
OSC	On-Scene Commander
P&I	protection and indemnity (insurance)
P&I	protection and indemnity
PAH	polycyclic aromatic hydrocarbons
PAIR	Pre-Arrival Information Reports
PIANC	World Association for Waterborne Transport Infrastructure
PMS	planned maintenance system
PORCP	National Places of Refuge Contingency Plan
PPA	Pacific Pilotage Authority
PPO	Pollution Prevention Officer
PPU	portable pilot units
PRPA	Prince Rupert Port Authority
PRPRCP	<i>Pacific Region Places of Refuge Contingency Plan</i>
PSC	Port State Control
QCDC	quick connect disconnect couplers
QRA	quantitative risk assessment
QRH	quick release hooks
QSCS	Quality System Certification Scheme
racon	radar beacon
RNC	raster navigational chart
RO	recognized organization (with respect to flag state affairs)
RO	response organization (with respect to spill response)
RT	radiotelephony
s	seconds
SAR	search and rescue
SIGTTO	Society of International Gas Tanker and Terminal Operators
SIRE	Ship Inspection Report Programme
SMPEP	Shipboard Marine Pollution Emergency Plan
SOLAS	<i>International Convention for the Safety of Life at Sea (SOLAS), 1974</i>
SOPEP	Shipboard Oil Pollution Emergency Plan
SOPF	Ship-source Oil Pollution Fund
SSL	ship-shore link
STCW	<i>International Convention on Training, Certification, and Watchkeeping for Seafarers</i>
SW	southwest
SWL	safe working load

Abbreviation	Description
t	metric tonne (equal to 1,000 kilograms)
TCMSS	Transport Canada Marine Safety and Security
TERMPOL	Technical Review Process of Marine Terminal Systems and Transshipment Sites
TOM	Terminal Operations Manual
Tp	peak wave period
TSB	Transportation Safety Board of Canada
UKC	underkeel clearance
US	United States
V-ATON	virtual aid to navigation
VDR	voyage data recorder
VHF	very high frequency
VLSFO	very low sulphur fuel oil
VTS	Vessel Traffic Services
WCMRC	Western Canada Marine Response Corporation

Preface

A Navigation Safety Assessment (NSA) is part of the Application. The NSA is an opportunity to review the Ksi Lisims LNG Project and determine whether additional resources (e.g., pilots), controls or infrastructure (e.g., navigational aids) are required and when they need to be in place. The NSA studies make-up Appendix E and findings inform Section 9 Malfunctions and Accidents and other sections (e.g., Section 7.11 Marine Use). Section 9.1.2 Planning provides a list and high-level description of the NSA studies. Additional navigation simulations will be completed before the start of operations and will be the subject of approval conditions.

1 Introduction

The *Contingency Planning and Hazardous and Noxious Substances (HNS) Report* describes the regulatory frameworks, best practices, and plans to address contingency planning for the Ksi Lisims LNG - Natural Gas Liquefaction and Marine Terminal Project (the Project).

This report summarizes the planning that will take place before the start of operations, so the Project is prepared to respond in the unlikely event of an incident at the marine terminal. The Project's contingency plans (i.e., Emergency Response Plan) and procedures will be developed during detailed project planning.

This report describes the regulatory regimes for contingency planning as well as the liability and compensation regimes to cover the costs of pollution cleanup and damage. The Project, liquefied natural gas (LNG) carriers and natural gas liquid (NGL) product vessels (see *Vessel Specifications Report* [1]) will meet statutory requirements for contingency planning. Different regulatory frameworks govern the contingency planning for vessels and marine terminals (see Appendix A for a list of applicable regulatory requirements).

1.1 Project Background

An overview of the Project is provided in the *Marine Route Report* [2]. As described in the *Casualty Data and Risk Analysis Report* [3], the Project is committed to further study of risk mitigation measures. Further safety assessments will be completed before the start of operations and will be communicated in:

- Tug specifications
- Terminal Operations Manual (TOM)
- Security plans
- Training plans
- Emergency Response Plan

The above documents will be provided to the applicable approving agencies at least six months before operations begin. The Project will notify agencies if any Project commitments, operational parameters, or characteristics are altered.

Preliminary emergency response measures to be further defined during subsequent stages of project development are outlined below and include statutory requirements and project-specific measures:

- The Project will prepare an Emergency Response Plan for the LNG facility, including the marine terminal, as required under the *Emergency Management Regulation* under the *Oil and Gas Activities Act* (OGAA)
- The Emergency Response Plan will include components such as emergency response training, communications, compliance monitoring, and exercises and drills. The Emergency Response Plan will be updated as necessary. The Project's Emergency Response Plan will be referenced in the TOM
- The Project will subscribe to Western Canada Marine Response Corporation (WCMRC) and will utilize WCMRC's training, contingency plan testing and associated services
- The Emergency Response Plan will include response equipment and personnel trained as first responders at the marine terminal. The Project will consult WCMRC with respect to the type and quantity of marine response equipment at the marine terminal and on tugs

- If required, tugs will be outfitted with firefighting and spill response equipment. The crews onboard the tugs may be trained in first response, including firefighting, deployment of spill response equipment and other emergency procedures
- The Project will complete emergency planning, emergency response training and exercises

1.2 Vessel Acceptance Program

The Project will have a vessel acceptance program for LNG carriers and NGL product vessels. The acceptance program will confirm that LNG carriers and NGL product vessels have the required certifications and have completed a satisfactory Ship Inspection Report Programme (SIRE) inspection in the 12 months before visiting the terminal. The program will confirm LNG carriers and NGL product vessels have in place the contingency plans required under international conventions and industry guidelines. Further information on the vessel acceptance program is provided in the *Vessel Specifications Report* [1].

2 International Requirements

Canada is signatory to international conventions [4] related to preparedness and response that all LNG carriers and NGL product vessels must adhere to, such as *International Convention for the Safety of Life at Sea (SOLAS)* [5] including the *International Safety Management (ISM) Code (ISM Code)* [6], and the *International Convention for the Prevention of Pollution of Ships (MARPOL)* [7].

The international conventions are enforced through the efforts of:

- LNG carrier and NGL product vessel operators
- Flag states
- Port state control
- Classification societies
- Protection and Indemnity insurance (P&I) clubs

LNG carrier and NGL product vessel operators are responsible for ensuring their vessels and crews meet the requirements of international conventions. Many operators have company requirements that exceed the minimum requirements. Operators will also need to meet the Project's vessel acceptance criteria (see Section 1.2). Ksi Lisims LNG may enforce non-compliances through commercial agreements.

Flag states are responsible for ensuring vessels flagged in their country are inspected under the international memoranda, conventions, and protocols the country has ratified, adopted, or acceded to. Most flag states delegate their inspections to classification societies acting as a recognized organization (RO). The flag state must monitor inspections by the RO's.

Port State Control (PSC) is where foreign vessels entering a sovereign state's waters are boarded and inspected to ensure compliance with international maritime conventions. PSC programs are regional with countries sharing common waters working under a memorandum of understanding (MOU, see *Vessel Specifications Report* [1]). The MOUs ensure vessels trading in the region are not substandard. In Canada, PSC inspections are carried out by Marine Safety Inspectors (MSI) from the Marine Safety Branch of Transport Canada. An inspection database and list of detained ships are maintained by the headquarters group at Transport Canada.

Classification societies are private organizations (often not-for-profit) with the expertise to establish and apply technical standards for the construction and operation of merchant ships. Commercial ships are built to, and surveyed for, compliance with the standards (i.e., Rules) established by classification societies. Rules incorporate the requirements of international conventions.

P&I clubs are independent, not-for-profit mutual insurance associations, providing cover for their shipowner and charterer members against third party liabilities arising out of the use and operation of ships. P&I clubs often share information to improve safety and reduce incidents.

2.1 SOLAS

SOLAS specifies minimum standards for the construction, equipment, and operation of ships, compatible with their safety. SOLAS outlines the requirements for fire protection, fire detection, and fire extinction as part of a vessel's contingency plans.

Flag States are responsible for ensuring that ships under their flag comply with its requirements, and several certificates are prescribed in SOLAS as proof this has been done.

2.1.1 ISM Code

The ISM Code provides an international standard for the safe management and operation of ships and for pollution prevention. The ISM Code is based on general principles and objectives, which include assessment of risks to ships, personnel and the environment and establishment of safeguards.

The ISM Code is expressed in broad terms so it can have a widespread application. All vessels must comply with the ISM Code. Chapter 8 of the ISM Code specifies emergency preparedness measures that companies managing vessels must develop, including:

- Operators must identify potential shipboard situations and establish procedures for managing them
- Operators shall establish a program for drills and exercise to prepare for emergency actions
- Operators must have in place measures to ensure the company's organization can respond to hazards, accidents, and emergency situations involving its ships

LNG carrier and NGL product vessel crews are trained to handle shipboard emergencies. Training and drills are regularly conducted and recorded as required by the ISM Code [6]. LNG carrier and NGL product vessel crews regularly conduct a variety of drills to prepare for emergency situations, including:

- Fire
- Collision
- Grounding
- Water leakage into hold
- Loss of containment
- Bunker spill
- Injury to personnel or health incident
- Rescue from higher voltage equipment
- Rescue from enclosed spaces
- Emergency evacuation

In all cases, the goals of emergency procedures and actions taken are to:

- Effect the rescue and treatment of casualties
- Safeguard other people and the public
- Maintain the integrity of the vessel
- Reduce damage to the environment and property
- Contain and bring the incident under control
- Preserve relevant records and equipment for subsequent enquiry

2.2 MARPOL

MARPOL is the main international convention covering prevention of pollution of the marine environment by ships from operational or accidental causes. MARPOL includes regulations aimed at preventing accidental pollution and pollution from routine operations.

MARPOL Annex I Regulation 37 requires that all ships of 400 gross tonnage and above carry an approved Shipboard Oil Pollution Emergency Plan (SOPEP) [5]. Article 3 of the *International Convention on Oil Pollution Preparedness, Response and Co-operation, 1990*, also requires a SOPEP for certain ships.

MARPOL Annex II Regulation 17 requires all ships of 150 gross tonnage and above carrying noxious liquid substances in bulk have an approved Shipboard Marine Pollution Emergency Plan (SMPEP) [7]. The SMPEP

may be combined with a SOPEP, since most of their contents are the same. The International Maritime Organization (IMO) has produced guidelines for the development of both SOPEPs and SMPEPs.

Canada is a signatory to MARPOL and will require approved SOPEP and SMPEP onboard vessels calling at the marine terminal.

According to *MARPOL Annex 1 Regulation 1(4)*, LNG carriers must have an International Oil Pollution Prevention Certificate and a SMPEP, which incorporates the SOPEP. The SMPEP includes of these sections [8]:

- Table of Contents
- Record of Changes
- Section 1: Preamble
- Section 2: Reporting Requirements
 - When to report
 - Information required
 - Whom to contact
- Section 3: Steps to Control Discharges
 - Operational spills
 - Spills resulting from casualties.
- Section 4: National and Local Coordination
- Section 5: Additional Information
- Minimum Appendices
 - List of Coastal State Contacts
 - List of Port Contacts
 - List of Ship Interest Contacts
 - Ship's plans and Drawings
 - General Arrangement Plan
 - Tank Plan
 - Fuel Oil Piping Diagram
 - Further Appendices on Owner's Decision

2.2.1 National Contact Points

IMO guidelines require shipboard emergency plans to include, as an appendix, the list of agencies or officials of administrations responsible for receiving and processing reports on incidents involving oil and/or harmful substances (i.e., List of National Operation Contact Points).

In Canadian waters the master or owner of a ship must report, without delay, any discharge or anticipated discharge of a pollutant. Initial reports should be made to any Marine Communications and Traffic Services (MCTS) Centre on the frequencies in the *Radio Aids to Marine Navigation* [9]. Spill reports can also be directed to the nearest Canadian Coast Guard (CCG) marine spill reporting phone line. Pollutant discharge reporting requirements for vessels are established in Section 132 of the Vessel Pollution and Dangerous Chemical Regulations.

2.3 STCW Convention and Code

The *International Convention on Training, Certification, and Watchkeeping for Seafarers* (STCW) [10] and its associated code outline the minimum requirements for seafarers internationally. Seafarers sailing on oil and gas tankers must have additional training specific to their vessel. STCW was updated in 2010, with changes made specific to the training required for LNG carriers. STCW chapters cover these topics:

- Chapter I: General provisions
- Chapter II: Master and deck department
- Chapter III: Engine department
- Chapter IV: Radiocommunication and radio personnel
- Chapter V: Special training requirements for personnel on certain types of ships
- Chapter VI: Emergency, occupational safety, medical care, and survival functions
- Chapter VII: Alternative certification
- Chapter VIII: Watchkeeping

The regulations in STCW are supported by the *Seafarers' Training, Certification and Watchkeeping (STCW) Code*. Part A of the STCW Code is mandatory with minimum standards of competency. Part B of the STCW Code contains recommended guidance intended to help implement STCW.

The Maritime Labour Convention, 2006 (MLC, 2006) is an international labour Convention adopted by the International Labour Organization (ILO) [11]. It provides international standards for the marine shipping industry. Among other requirements, the MLC, 2006 requires all vessels over gross tonnage to have a valid Safe Manning Document (SMD) issued by the vessel's flag state. Minimum safe manning levels are established on a ship-by-ship basis, considering relevant operational.

2.4 International Best Practices

The Society of International Gas Tanker and Terminal Operators (SIGTTO) publishes industry best practices in addition to IMO requirements. The IMO and SIGTTO have published guidelines on creating a single SMPEP for gas carriers, namely *the Guidelines for the Development of SMPEP's of Oil and/or Noxious Liquid Substances (Resolution MEPC.85 [44], as amended by resolution MEPC.137 [53])* [12].

The International Chamber of Shipping has published the *Tanker Safety Guide (Liquefied Gas)* that serves as industry guidance on the safe operation of chemical tankers and outlines the properties of LNG, precautions, hazards, and emergency procedures.

2.5 Incident Command System

Incident Command System (ICS) is a standardized on-scene emergency management tool specifically designed to allow users to adopt an integrated organizational structure equal to the complexity and demands of single or multiple incidents, without being hindered by jurisdictional boundaries [13].

CCG policy stipulates that all marine pollution incidents, for which the CCG is the lead agency, will be managed through the ICS. Project contingency plans will also be managed through the ICS (see Section 5).

2.6 OPRC-HNS Protocol

The IMO has established the *Protocol on Preparedness, Response, and Co-operation to Pollution Incidents by Hazardous and Noxious Substances, 2000* (OPRC-HNS Protocol) as an addition to the *International Convention on Oil Pollution, Preparedness, and Co-operation* (OPRC Convention) [14].

The OPRC-HNS Protocol aims to ensure that there are preparedness and response measures in place around the world to protect against pollution from ships carrying HNS. These measures are similar to those already in place for ship-source oil spills, and include [15]:

- Pollution incident emergency plans for prescribed vessels, HNS handling facilities, and ports
- A national contingency plan and exercise program that includes HNS
- A minimum level of prepositioned equipment
- Arrangements, including communication procedures and coordination mechanisms, to help coordinate and facilitate the response to an HNS incident
- International cooperation regarding all aspects of HNS preparedness and response

Canada is working on developing an HNS regime and has ratified the OPRC-HNS Protocol [16]

3 Canada's Preparedness and Response Regime

Canada's ship-source oil spill preparedness and response regime is based on the "polluter pays" principle, with the party responsible for pollution being responsible for costs related to cleanup and pollution damage. The regime sets the guidelines and regulatory structure for the preparedness and response to marine oil spills and ensures that industry is prepared for, and responds to, spills in Canadian waters.

3.1.1 Transport Canada

Transport Canada is the lead regulatory agency for the preparation and response to ship-source oil pollution spills. Transport Canada is also responsible for the design and regulation of an HNS regime and for making sure the resources are in place to establish the national response capacity for:

- Ship pollution response plans
- Handling facility pollution response plans
- Monitoring response organization exercises
- Enforcement and compliance

Transport Canada works with stakeholders through a network of six Regional Advisory Councils [17] to advise the Minister of Transport. Each Council has seven members, representing people, groups, and companies whose interests could be affected by spills.

3.1.2 Canadian Coast Guard

For incidents within the CCG's mandate, the CCG is the lead agency and Incident Commander and will work with the polluter (i.e., if known, willing and able) and representatives from federal / provincial / territorial agencies, Indigenous communities, and municipalities in a single or Unified Command setting for the successful resolution of the incident.

Unified Command is intended to consist of a single representative from each of the following, when possible: federal government, Indigenous groups, provincial government, local government, and polluter.

The Environmental Unit (EU) is housed within the Planning Section of the Unified Command and is central to the development of strategies and tactics during a marine pollution incident response. The EU's primary responsibility is to recognize and weigh social, cultural, ecological, and commercial values supported by science and local knowledge when making recommendations to Unified Command. The EU strives to be inclusive of all interests, even if they are not represented in the EU. As such, EU participation will be primarily governmental agencies, Indigenous groups, and polluter representatives with interests and mandates in resource management and protection. The EU aims to make recommendations collaboratively, and these recommendations are conveyed to Unified Command to aid in decision making. EU recommendations are incorporated in the Incident Action Plan and communicated during scheduled meetings.

The CCG regularly conducts or participates in emergency response exercises with partners and stakeholders to ensure a rapid and effective response to incidents.

3.2 Other Agencies

Other federal departments assist the CCG. Environment and Climate Change Canada (ECCC) can convene the Environmental Emergencies Science Table to provide consolidated, consensus-based environmental advice on protection and cleanup priorities for consideration and to those responsible for cleanup action. Members of the Environmental Emergencies Science Table include:

- Response agencies
- All levels of government
- Affected Indigenous Nations
- Local communities
- Industries
- Environmental non-government organizations
- Academic institutions

3.3 Response Organizations

Industry is liable and responsible to respond to marine incidents in Canadian waters. Industry can meet this obligation through subscribing to industry-funded Response Organizations. Response Organizations are regulated under the Response Organizations Regulations [20] under the *Canada Shipping Act, 2001*.

Response Organizations are equipped, and Transport Canada certified, to respond to marine oil pollution incidents. Separate arrangements must be in place to respond to incidents involving the release of HNS.

Prescribed vessels entering Canadian waters must have an arrangement with the appropriate response organization for spill response, which on Canada's west coast is WCMRC. Prescribed vessels are defined under the Environmental Response Regulations [21] under the *Canada Shipping Act, 2001* and include:

- Oil tankers of 150 gross tonnage or more
- Vessels, other than oil tankers, of 400 gross tonnage or more that carry oil as cargo or as fuel
- Vessels that carry oil as cargo or as fuel and that are engaged in towing or pushing at least one other vessel that carries oil as cargo or as fuel if the combined gross tonnage of the vessels is 150 gross tonnage or more

The Environmental Response Regulations define an oil tanker to include the following vessels that are carrying a cargo or part cargo of oil in bulk:

- A combination carrier, which is a vessel designed to carry oil or solid cargoes in bulk
- A noxious liquid substances (NLS) tanker, which is a vessel constructed or adapted to carry a cargo of noxious liquid substances in bulk and includes an oil tanker that is certified to carry a cargo or part cargo of noxious liquid substances in bulk
- A gas carrier, which is a cargo vessel constructed or adapted for the carriage in bulk of any liquefied gas or other products listed in Chapter 19 of the *International Code for the Construction and Equipment of Ships Carrying Liquefied Gases in Bulk*, published by the IMO

3.3.1 Western Canada Marine Response Corporation

WCMRC is the Transport Canada certified response organization for Canada's west coast [22]. WCMRC has a Tier 4 capability under the *Response Organizations Standards* [22]. WCMRC has the capacity to respond to a 10,000 tonne spill within time standards and operating environments. WCMRC can be supplemented by the CCG, by resources from other regions, or internationally through the OPRC.

The responsibilities of the WCMRC under the Response Organizations Regulations [20] are to demonstrate in its response plan it can comply with the requirements relating to the procedures, equipment, and resources for its geographical area (i.e., Canada's west coast). This includes implementing the procedures outlined in section 4(1) and securing equipment and resources outlined in section 4(2) of the Response Organizations Regulations [20].

To meet the objectives of the Response Organizations Regulations [20], WCMRC maintains:

- Marine spill response plans including geographical response strategies. WCMRC’s response plans must consider any contingency plan issued by the CCG
- A group of trained response personnel
- Marine spill response equipment. The WCMRC’s network of assets is in Figure 1
- Relationships with fishing vessels and commercial vessels suitable for responding to marine spills. The program is called the Vessels of Opportunity
- Relationships with third party contractors and mutual aid organizations in Canada, Washington State, and Alaska to assist in the event of an incident larger than WCMRC can respond to alone

While the Environmental Response Regulations of the *Canada Shipping Act, 2001* may not apply to LNG operations, the Project will subscribe to WCMRC and will utilize WCMRC’s training, contingency plan testing and associated services.

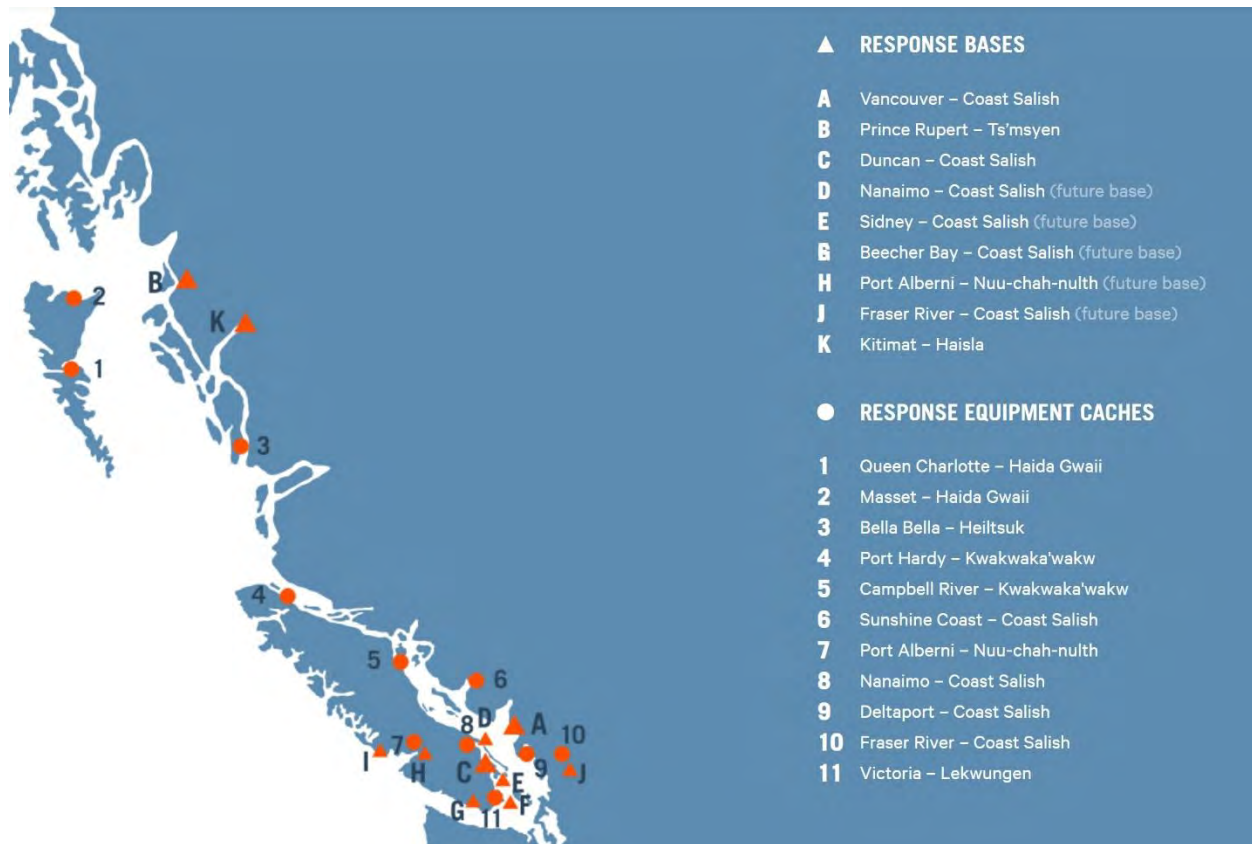

Figure 1 - WCMRC network [23]

3.3.2 Planning Standards

The *Response Organizations Standards* [22] under the Environmental Response Regulations [21] under the *Canada Shipping Act, 2001* [7] set out the tiered response capabilities that ROs must meet to be certified to respond to spills in Canada’s waters. The *Response Organizations Standards* [22] specify the time in which an RO must respond to a spill of a specified quantity. The standards also set out the number of metres of shoreline to be treated each day during a response operation and the number of days in which on water recovery operations must be completed.

The marine shipping route is considered a Tier 3 to 4 area, with equipment to be deployed to site within 18 to 72 hours with additional travel time [24]. The closest WCMRC response base is in Prince Rupert, and

there is a response equipment cache in Masset, Haida Gwaii. The Project will also have response equipment at the marine terminal and, if required, onboard tugs. Project personnel will be trained as required under Canadian statutes and industry best practices.

3.3.3 Certification

Transport Canada oversees compliance with preparedness requirements. To be certified, ROs must demonstrate their capacity to respond to spills under a variety of circumstances. This certification process is required every three years under the Response Organizations Regulations [20]. To meet the requirements, ROs hold tabletop and equipment deployment exercises and oil spill response training courses at the intervals in Table 1.

Table 1 - Response organization exercises and frequency

Exercise	Frequency
150 tonne equipment deployment	Annually
1,000 tonne tabletop scenarios	Annually
2,500 tonne equipment deployment	Bi-annually
10,000 tonne tabletop scenarios	Every three years

3.4 Places of Refuge

Transport Canada is responsible for developing and managing the *National Places of Refuge Contingency Plan* (PORCP) and regional places of refuge contingency plans, which provides the framework for ships needing assistance seeking refuge in Canadian waters. Transport Canada is the lead department for decisions related to vessels requesting assistance and place of refuge. The PORCP applies to requests for a place of refuge from ships in Canadian waters and where a ship destined for Canada reports a problem.

The *Pacific Region Places of Refuge Contingency Plan* (PRPRCP) complements the PORCP by establishing a framework to respond to requests for assistance within the region. The PRPRCP is based on the IMO's *Guidelines on Places of Refuge for Ships in Need of Assistance*. The PRPRCP and PORCP provide a national framework for effectively and efficiently responding to requests from ships seeking a place of refuge in Canadian waters. The goals of the plans are to:

- Stabilize the vessels condition
- Reduce hazards to navigation
- Protect human life, the environment, and other socio-economic and cultural interests

Transport Canada and the CCG cooperate along with Indigenous communities, industry partners and other authorities, to optimize the response to the request or need for refuge. If a vessel has discharged or is likely to discharge pollution, authorities would follow the PRPRCP with existing response procedures and contingency plans.

4 Considerations for Response Planning

4.1 LNG Properties

LNG is natural gas cooled to minus 160° C at atmospheric pressure to form a liquid. LNG is clear, colourless, odourless, non-corrosive and non-toxic. While natural gas is not toxic, concentrated clouds of natural gas do not contain sufficient oxygen and can cause asphyxiation. Due to its cryogenic nature, LNG will freeze any material it contacts, including seawater.

A cargo tank breach at, or above, the waterline would result in LNG flowing out under gravity to the level of the breach. LNG is lighter than water and will float on the surface. LNG will absorb heat from the water and rapidly return to a gaseous form. Natural gas is lighter than air at ambient temperatures. However, the gas from LNG is initially cold and heavier than air. Natural gas clouds will therefore spread and disperse downwind at water level, before rising as the vapour warms [25].

As a liquid, LNG cannot explode and is not flammable. Only when LNG is warmed and returns to its gaseous state and mixes with air in certain proportions (i.e., between 5% and 15%) does the mixture become flammable (or explosive if in a confined environment) [26]. The most likely result of a spill of LNG that ignites, is a fire burning at the edges of the spill where gas concentrations are within the flammable limits (i.e., a pool fire [25]). Because LNG liquid cannot burn, and LNG cargoes are not pressurized, LNG cargo releases cannot form a jet fire. Burning of unconfined vapours does not produce a pressure wave [25].

Considerations to be included in emergency response plans include:

- As the cargo rapidly transitions back to a gas, there is no potential for containing or collecting the cargo as there is for oil spills
- LNG does not enter the water column, and the natural gas released is non-toxic and will disperse relatively quickly in open spaces, meaning no intervention is needed to prevent harm to marine animals or to preserve habitat
- Immediate safety measures will focus on evacuation to prevent cryogenic burns from contact with LNG, or risk of asphyxiation or fire injury. Personnel should evacuate to a safe distance upwind of the release
- Adding water to an LNG pool fire will both spread the pool and vaporise more liquid, making the fire larger and more intense than if no water was added. In certain circumstances, it may be advantageous to accelerate warming of the LNG pool to reduce the duration of the flammability hazard [25]
- Use of water sprays to dilute vapours or to form a “curtain” between LNG vapours and potential ignition sources can help manage the risk from the vapour cloud [25]
- Heat radiation from an LNG fire can present a risk to equipment or other flammable elements near the fire. Water sprays can cool the areas near the fire to mitigate this risk
- LNG fires can be controlled or extinguished with expanding foam or dry-chemical extinguishers. However, the fire should not be extinguished unless it is possible to close off the source of LNG to avoid further flammable gases being generated that may reignite [25]
- Fires should be fought from the maximum distance possible. For a large fire, unmanned hose holders or nozzles are required. If this is not possible, or if fires are near unruptured tanks, all personnel should withdraw from the area and let the fire burn out [27]

4.2 Condensate

Condensates are low density, low-viscosity, liquid hydrocarbons that typically occur along with natural gas. Condensates can vary in appearance from colourless to yellow or brown and are typically composed of saturated hydrocarbons such as butane, pentane, and hexane. Condensates have a low solubility in water and are highly volatile. Condensates also have a low density and if spilled, typically float on the sea surface [28]. The majority of condensate will evaporate quickly (i.e., within hours or days), while some residual heavy components will take longer (i.e., days to weeks) to degrade.

Condensate liquid and vapour flammability is the primary safety hazard in a spill. Condensate vapours are heavier than air and may spread along the water surface to a distant ignition source and flash back. Condensate liquid and vapours are toxic. With wave action, small fractions of toxic compounds found in the condensate could effect marine life in the first few metres of the water column [28].

Considerations to be included in emergency response plans include:

- Condensates typically break up naturally in wind and waves, with the majority evaporating within days
- Traditional “oil” containment and recovery operations are not typically recommended. Any attempt to concentrate the condensate would reduce the rate of evaporation and increase the risk of ignition [28]
- Dispersants are ineffective on condensate spills as they will 'herd' the sheen rather than promote the formation of droplets in the water column [28]
- For a marine spill that does not ignite, the source should be shut off if it can be done safely and personnel should be evacuated in the downwind area [29]
- In situ burning is potentially an option for condensate, but may be difficult to achieve safely [28]
- For a condensate spill that ignites, using water jets directly will spread the fire. Water may cool surrounding areas from as far away as possible until well after the fire is out
- For a massive fire, unmanned hose holders or nozzles are required. If this is not possible, or if fires are near unruptured tanks, all personnel should withdraw from the area and let the fire burn out [29]

5 Marine Terminal Contingency Plan

In addition to complying with regulatory requirements, the Project will require LNG carriers and NGL product vessels to follow specific operational procedures for safe cargo management onboard the ship at the marine terminal. These procedures will be consistent with industry guidelines, such as:

- *Guide to Contingency Planning for Marine Terminals Handling Liquefied Gases in Bulk* published by SIGTTO
- *Support Craft at Liquefied Gas Facilities. Principles of Emergency Response and Protection* published by SIGTTO
- *Contingency planning for spills on water* published by ipieca

The Project will prepare an Emergency Response Plan for the LNG facility, including the marine terminal, as required under the *Emergency Management Regulation* under the OGAA. The Project will provide the Emergency Response Plan to Transport Canada and the CCG at least six months before operations begin.

The preliminary Emergency Response Plan table of contents includes the following topics:

- Definitions
- Project policies and procedures
- Project organization and contacts
- Types of incidents that may be encountered at the marine terminal or on LNG carriers or NGL product vessels alongside the marine terminal
- Reporting procedures for different incidents
- Communications plan, including up to date:
 - Internal call-out list
 - External call-out list
 - Contact list for potential support services
 - Communication methods available
 - Emergency call procedures
- Site plans and descriptions
- Resources available at the marine terminal
- A list of resources available from:
 - WCMRC
 - Other parties on North Coast
 - Government agencies including the CCG
 - Third party contractors
- A plan for remedial action for any damage caused by the accident or incident
- The location of an Emergency Operations Centre (EOC), and an alternative location
- Staffing of the EOC
- Project responsibilities in relation to an accident or incident
- A training program
- A contingency plan exercise program

The emergencies that marine terminal staff will be trained to address include:

- Fire at the marine terminal, with or without an LNG carrier or NGL product vessel alongside
- Fire onboard an LNG carrier or NGL product vessel when alongside the marine terminal
- Loss of containment
- Structural damage
- Personnel injuries
- Persons in the water
- Equipment malfunctions
- Deteriorating weather conditions and possible evacuation of the berth
- Fuel oil or other persistent spills from the marine terminal or vessels alongside the marine terminal
- Natural phenomena which may affect operations

In addition to preparing the Emergency Response Plan, the following steps will be taken by the Project:

- The Project will provide response equipment at the marine terminal
- If required, tugs will be outfitted with fire fighting and spill response equipment
- The type and quantity of response equipment will be reviewed with WCMRC
- A tug will remain on standby while LNG carriers are berthed
- Tug crews may be trained in first response, including firefighting, deployment of oil spill response equipment and other emergency procedures
- Management and reporting under the Emergency Response Plan will be based on the ICS
- Terminal crews will be trained before the start of operations on response equipment
- Terminal personnel will receive formal ICS training before operations begin
- The Project's contingency plans will be referenced in the TOM
- The TOM will be provided to the LNG carriers and NGL vessels (before arrival) and will include actions to be taken in the event of an incident
- The pre-transfer meeting between personnel from marine terminal and personnel from the LNG carrier or NGL product vessel at berth will include further discussion of emergency communications and the action to be taken
- The Project will communicate contingency planning to communities near the marine terminal and along the selected marine route. Opportunities for sharing resources and joint training will be reviewed
- The Project will complete emergency planning, emergency response training and exercises

5.1 Nisga'a Lisims Government

The Nisga'a Lisims Government (NLG) has completed CCG-sponsored emergency response training, recently participating with the CCG, Transport Canada, and the US Coast Guard in a desktop spill response exercise.

The NLG have a vessel that can assist in spill response. However, the vessel is not adequate to transport all the equipment that may be required for a response. NLG are working with the CCG to purchase and deploy a more suitable vessel for emergency response [30].

The NLG maintains a cache of spill response equipment in Gingolx. An overall NLG Marine Emergency Response Plan is planned but not yet started.

6 Liability and Compensation

This section outlines sources of compensation for economic loss from ship-source pollution.

6.1 Marine Liability Act

The *Marine Liability Act* addresses liability of shipowners in relation to passengers, cargo, pollution, and property damage. The *Marine Liability Act* establishes rules on liability and compensation based on international conventions that require shipowners to provide compensation to affected parties [31].

Under Canada's *Marine Liability Act*, ship owners are liable for costs associated with preventive measures and response for pollution incidents up to the limits of their liability. Polluters are financially responsible, even if the spill is accidental [32]. If a shipowner's insurance doesn't cover the full costs of pollution from an oil or fuel spill, international and domestic funds are also available [32].

6.2 Ship-Source Oil Pollution Fund

The *Marine Liability Act* establishes the Ship-Source Oil Pollution Fund (SOPF, the Fund) [31]. The Fund covers incidents where vessel insurance and international funds do not provide coverage [33]. In 2018 changes to the *Marine Liability Act* made compensation available for ship-source oil pollution caused by any oil (persistent or non-persistent [34]) from any ship in Canadian waters [32].

Those affected by a spill can submit a claim directly to the Fund. There is no limit to compensation available from the Fund [35].

6.3 International Funds

This section discusses international funds applicable to LNG carriers and NGL vessels.

6.3.1 Bunkers Convention

The *International Convention on Civil Liability for Bunker Oil Pollution Damage* (Bunkers Convention) was adopted by the IMO to ensure that adequate, prompt, and effective compensation is available to persons who suffer damage caused by spills of oil, when carried as fuel.

The Bunkers Convention applies to all seagoing vessels carrying oil on board either for the propulsion or operation of the ship. Ships of over 1,000 gross tonnage must maintain insurance for oil pollution damage.

On June 23, 2009, amendments to the *Marine Liability Act* [36] implemented the Bunkers Convention in Canada. On October 2, 2009, Canada ratified the Bunkers Convention.

6.3.2 2010 HNS Convention

HNS refers to any substance other than oil that, if released, would have a negative effect on public health and safety, the environment, or local economic activity.

The *International Convention on Liability and Compensation for Damage in Connection with the Carriage of Hazardous and Noxious Substances by Sea, 2010* (2010 HNS Convention) [37] seeks to provide adequate, prompt, and effective compensation for HNS incidents. The 2010 HNS Convention covers:

- Loss of life or personal injury on board or outside the ship
- Loss of, or damage to, property outside the ship

- Loss or damage caused by contamination of the environment
- Costs of preventive measures taken by any person after an incident has occurred to prevent or mitigate damage
- Costs of reasonable measures of reinstatement of the environment

Amendments made to the *Marine Liability Act* received Royal Assent in 2014 [31]. On April 23, 2018, Canada officially ratified the 2010 HNS Convention [38] and will continue to lead the international efforts to bring the 2010 HNS Convention into force [31].

References

- [1] Westmar Advisors Inc., "Vessel Specifications," 1220197-P01-24-RPT-0001, 2023.
- [2] Westmar Advisors Inc., "Marine Route," 1220197_P01_22_RPT_0001, 2023.
- [3] Westmar Advisors Inc., "Casualty Data and Risk Analysis," 1220197-P01-23-RPT-0001, 2023.
- [4] International Maritime Organization, "Status of Conventions." Accessed: Nov. 20, 2022. [Online]. Available: <https://www.imo.org/en/About/Conventions/Pages/StatusOfConventions.aspx>
- [5] International Maritime Organization, "International Convention for the Safety of Life at Sea (SOLAS)." Accessed: Aug. 22, 2022. [Online]. Available: [https://www.imo.org/en/About/Conventions/Pages/International-Convention-for-the-Safety-of-Life-at-Sea-\(SOLAS\),-1974.aspx](https://www.imo.org/en/About/Conventions/Pages/International-Convention-for-the-Safety-of-Life-at-Sea-(SOLAS),-1974.aspx)
- [6] International Maritime Organization, "The International Safety Management (ISM) Code." Accessed: Aug. 22, 2022. [Online]. Available: <https://www.imo.org/en/OurWork/HumanElement/Pages/ISMCode.aspx>
- [7] International Maritime Organization, "International Convention for the Prevention of Pollution from Ships (MARPOL)," *Int. leg. mater.*, vol. 17, no. 3, p. 45, Nov. 1973, doi: 10.1017/S0020782900052013.
- [8] International Maritime Organization, "Resolution MEPC.85(44)." Accessed: Aug. 22, 2022. [Online]. Available: [https://wwwcdn.imo.org/localresources/en/OurWork/Environment/Documents/SOPEP/MEPC.85\(44\).pdf](https://wwwcdn.imo.org/localresources/en/OurWork/Environment/Documents/SOPEP/MEPC.85(44).pdf)
- [9] Canadian Coast Guard, "Radio Aids to Marine Navigation 2023." 2023.
- [10] International Maritime Organization, "International Convention on Standards of Training, Certification and Watchkeeping for Seafarers." Accessed: Aug. 30, 2022. [Online]. Available: <https://www.imo.org/en/OurWork/HumanElement/Pages/STCW-Convention.aspx>
- [11] "Basic facts on the Maritime Labour Convention 2006." Accessed: Oct. 01, 2023. [Online]. Available: http://www.ilo.org/global/standards/maritime-labour-convention/what-it-does/WCMS_219665/lang-en/index.htm
- [12] International Maritime Organization, "Shipboard Marine Pollution Emergency Plans." Accessed: Nov. 20, 2022. [Online]. Available: <https://www.imo.org/en/OurWork/Environment/Pages/Shipboard-Marine-Pollution-Emergency-Plans.aspx>
- [13] Operations Directorate, Fisheries and Oceans Canada, and Canadian Coast Guard, "Marine Spills Contingency Plan – National Chapter." May 31, 2018. Accessed: Nov. 11, 2022. [Online]. Available: <https://www.ccg-gcc.gc.ca/publications/environmental-environnementale/marine-pollution-deversements-en-mer/s01-eng.html>
- [14] International Maritime Organization, "Protocol on Preparedness, Response and Co-operation to Pollution Incidents by Hazardous and Noxious Substances, 2000 (OPRC-HNS Protocol)." Accessed: Nov. 20, 2022. [Online]. Available: [https://www.imo.org/en/About/Conventions/Pages/Protocol-on-Preparedness,-Response-and-Co-operation-to-pollution-Incidents-by-Hazardous-and-Noxious-Substances-\(OPRC-HNS-Pr.aspx](https://www.imo.org/en/About/Conventions/Pages/Protocol-on-Preparedness,-Response-and-Co-operation-to-pollution-Incidents-by-Hazardous-and-Noxious-Substances-(OPRC-HNS-Pr.aspx)
- [15] Transport Canada, "A Review of Canada's Ship-source Spill Preparedness and Response: Setting the Course for the Future, Phase II," *Government of Canada*, p. 120, Sep. 2014.

- [16] Environment and Climate Change Canada, "International Convention on Oil Pollution Preparedness, Response, and Cooperation." Accessed: Nov. 20, 2022. [Online]. Available: <https://www.canada.ca/en/environment-climate-change/corporate/international-affairs/partnerships-organizations/convention-oil-pollution-preparedness-response-cooperation.html>
- [17] Transport Canada, "Oil Spill Response Canada Membership," Transport Canada. Accessed: Nov. 20, 2022. [Online]. Available: <https://tc.canada.ca/en/marine-transportation/marine-safety/membership>
- [18] SC 2001, c 26 | *Canada Shipping Act, 2001*. CanLII. Accessed: Jul. 26, 2023. [Online]. Available: <https://www.canlii.org/en/ca/laws/stat/sc-2001-c-26/160998/sc-2001-c-26.html>
- [19] SC 1996, c 31 | *Oceans Act*. CanLII. Accessed: Jul. 26, 2023. [Online]. Available: <https://www.canlii.org/en/ca/laws/stat/sc-1996-c-31/160987/sc-1996-c-31.html>
- [20] L. S. Branch, "Response Organizations Regulations." Accessed: Aug. 06, 2023. [Online]. Available: <https://laws-lois.justice.gc.ca/eng/regulations/SOR-95-405/index.html>
- [21] SOR/2019-252 | *Environmental Response Regulations*. CanLII. Accessed: Jul. 26, 2023. [Online]. Available: <https://www.canlii.org/en/ca/laws/regu/sor-2019-252/160613/sor-2019-252.html>
- [22] Transport Canada, "Response Organization Standards - TP 12401." 1995. Accessed: Nov. 20, 2022. [Online]. Available: <https://tc.canada.ca/sites/default/files/migrated/tp12401e.pdf>
- [23] Western Canada Marine Response Corporation, "Response capability for ship-source marine spills along Canada's West Coast," WCMRC. Accessed: Sep. 06, 2022. [Online]. Available: <https://wcmrc.com/preparedness/capacity/>
- [24] Western Canada Marine Response Corporation, "Canadian Spill Response Regime," WCMRC. Accessed: Sep. 06, 2022. [Online]. Available: <https://wcmrc.com/preparedness/canadian-spill-response-regime/>
- [25] Ann Walker, "Response Considerations for LNG Spills," Jan. 2006. Accessed: Jul. 25, 2023. [Online]. Available: https://www.researchgate.net/publication/320335739_RESPONSE_CONSIDERATIONS_FOR_LNG_SPILLS
- [26] Natural Resources Canada, "Liquified Natural Gas: Properties and Reliability," Liquified Natural Gas: Properties and Reliability. Accessed: Jan. 18, 2023. [Online]. Available: <https://www.nrcan.gc.ca/sites/www.nrcan.gc.ca/files/energy/pdf/eneene/pdf/proprefia-eng.pdf>
- [27] Fortis BC, "Safety Data Sheet - Liquid Natural Gas." Accessed: Jan. 19, 2023. [Online]. Available: <https://www.cdn.fortisbc.com/libraries/docs/librariesprovider3/default-document-library/liquefiednaturalgasosha-whmis-ghsds.pdf>
- [28] International Tanker Owners Pollution Federation Limited, "Condensates - Promoting Effective Spill Response," ITOPF. Accessed: Aug. 30, 2022. [Online]. Available: <https://www.itopf.org/knowledge-resources/documents-guides/condensates/>
- [29] Keyera, "Condensate Safety Data Sheet." Accessed: Jan. 19, 2023. [Online]. Available: <https://www.keyera.com/assets/Attachments/Safety-Data-Sheets-2021/Sales-Products/English/Condensate-PG-1-Sweet-SDS-EN.pdf>
- [30] C. C. Guard, "Canadian Coast Guard Partners with Indigenous Coastal Communities to Enhance Marine Safety." Accessed: Jan. 22, 2023. [Online]. Available: <https://www.newswire.ca/news-releases/canadian-coast-guard-partners-with-indigenous-coastal-communities-to-enhance-marine-safety-870262503.html>

- [31] Transport Canada, "Canada's Marine Safety and Security System, August 2018 Revision." Accessed: Jun. 09, 2023. [Online]. Available: <https://apps.cer-rec.gc.ca/REGDOCS/File/Download/3643984>
- [32] Transport Canada, "Marine liability and compensation: oil spills," AH 16052025. Accessed: Jun. 08, 2023. [Online]. Available: <https://tc.canada.ca/en/marine-transportation/marine-safety/marine-liability-compensation-oil-spills>
- [33] Anne Legars, "More than just big spills from tankers." SOPF, May 2019. Accessed: Aug. 23, 2022. [Online]. Available: <https://sopf.gc.ca/wp-content/uploads/pdf/BCSN-May19-Pg14-18.pdf>
- [34] Transport Canada, "Enbridge Northern Gateway Project Joint Review Panel." Accessed: Aug. 30, 2022. [Online]. Available: https://www.ceaa-acee.gc.ca/050/documents_staticpost/cearef_21799/83452/Vol7_-_Part02.pdf
- [35] Ship-source Oil Pollution Fund, "Frequently Asked Questions." Accessed: Oct. 19, 2022. [Online]. Available: https://sopf.gc.ca/?page_id=460
- [36] SC 2001, c 6 | *Marine Liability Act*. CanLII. Accessed: Jul. 26, 2023. [Online]. Available: <https://www.canlii.org/en/ca/laws/stat/sc-2001-c-6/187148/sc-2001-c-6.html>
- [37] International Maritime Organization, "International Convention on Liability and Compensation for Damage in Connection with the Carriage of Hazardous and Noxious Substances by Sea (HNS Convention)." 2010. Accessed: Aug. 06, 2023. [Online]. Available: https://www.hnsconvention.org/wp-content/uploads/2018/08/2010-HNS-Convention-Consolidated-text_e.pdf
- [38] Environment and Climate Change Canada, "Protocol of 2010 to the International Convention on Liability and Compensation for Damage in Connection with the Carriage of Hazardous and Noxious Substances by Sea, 1996 (2010 HNS Protocol)," 2020, Accessed: Aug. 23, 2022. [Online]. Available: <https://www.canada.ca/content/dam/eccc/documents/pdf/international-affairs/compendium/2020/batch-5/compensation-damage-hazardous-noxious-substances-sea.pdf>
- [39] Transport Canada, "National Places of Refuge Contingency Plan (PORCP) - TP 14707 E," Transport Canada. Accessed: Aug. 30, 2022. [Online]. Available: <https://tc.canada.ca/en/marine-transportation/marine-safety/national-places-refuge-contingency-plan-porcp-tp-14707-e>
- [40] International Maritime Organization, "List of IMO Conventions." Accessed: Nov. 20, 2022. [Online]. Available: <https://www.imo.org/en/About/Conventions/Pages/ListOfConventions.aspx>
- [41] BC Reg 146/2014 | *Liquefied Natural Gas Facility Regulation*. CanLII, 2014. Accessed: Jul. 26, 2023. [Online]. Available: <https://www.canlii.org/en/bc/laws/regu/bc-reg-146-2014/187589/bc-reg-146-2014.html>
- [42] BC Reg 187/2017 | *Spill Reporting Regulation*. CanLII, 2017. Accessed: Jul. 26, 2023. [Online]. Available: <https://www.canlii.org/en/bc/laws/regu/bc-reg-187-2017/133782/bc-reg-187-2017.html>
- [43] SBC 2003, c 53 | *Environmental Management Act*. CanLII. Accessed: Jul. 26, 2023. [Online]. Available: <https://www.canlii.org/en/bc/laws/stat/sbc-2003-c-53/210913/sbc-2003-c-53.html>
- [44] SOR/2019-51 | *Environmental Emergency Regulations, 2019*. CanLII. Accessed: Jul. 26, 2023. [Online]. Available: <https://www.canlii.org/en/ca/laws/regu/sor-2019-51/146381/sor-2019-51.html>
- [45] SC 1999, c 33 | *Canadian Environmental Protection Act, 1999*. CanLII. Accessed: Jul. 26, 2023. [Online]. Available: <https://www.canlii.org/en/ca/laws/stat/sc-1999-c-33/213938/sc-1999-c-33.html>
- [46] Canadian Standards Association, "CSA Z246.2-18 - Emergency preparedness and response for petroleum and natural gas industry systems," CSA Group. Accessed: Nov. 20, 2022. [Online]. Available: <https://www.csagroup.org/store/product/Z246.2-18/>

- [47] Canadian Standards Association, "CSA Z662:19 - Oil and gas pipeline systems," CSA Group. Accessed: Nov. 20, 2022. [Online]. Available: <https://www.csagroup.org/store/product/CSA%20Z662:19/>
- [48] Canadian Standards Association, "CSA Z276:22 - Liquefied natural gas (LNG) - Production, storage, and handling," CSA Group. Accessed: Nov. 20, 2022. [Online]. Available: <https://www.csagroup.org/store/product/2701470/>

Appendix A

Contingency Planning Documents



A Contingency Planning Documents

Table A-1 – Vessel contingency planning documents

Regulatory Body	Regulation
Preparedness and response	
Transport Canada	<ul style="list-style-type: none"> • Canada Shipping Act, 2001 [18] • National Places of Refuge Contingency Plan (PORCP) (TP 14707E) [39] • Places of refuge contingency plan (Pacific Region) (TP 14707E) [39]
Canadian Coast Guard	<ul style="list-style-type: none"> • Marine Spills Contingency Plan – National Chapter [13]
International Conventions[40]	<ul style="list-style-type: none"> • International Convention for the Safety of Life at Sea (SOLAS, 1974, as amended) • The ISM Code under the 1994 amendments to the SOLAS Convention (chapter IX, as amended) [6] • International Convention for the Prevention of Pollution from Ships, 1973, as modified by the Protocol of 1978 relating thereto and by the Protocol of 1997 (MARPOL) • International Convention on Standards of Training, Certification and Watchkeeping for Seafarers (STCW) as amended, including the 1995 and 2010 Manila Amendments • International Convention on Oil Pollution Preparedness, Response and Co-operation (OPRC), 1990 • Protocol on Preparedness, Response and Co-operation to pollution Incidents by Hazardous and Noxious Substances, 2000 (OPRC-HNS Protocol)
Liability and compensation	
Transport Canada	<ul style="list-style-type: none"> • Marine Liability Act [36] • Environmental Response Regulations [21]
International Conventions[40]	<ul style="list-style-type: none"> • International Convention on Civil Liability for Oil Pollution Damage (CLC), 1969 • 1992 Protocol to the International Convention on the Establishment of an International Fund for Compensation for Oil Pollution Damage (FUND 1992) • International Convention on Liability and Compensation for Damage in Connection with the Carriage of Hazardous and Noxious Substances by Sea, 2010 (2010 HNS Convention) • International Convention on Civil Liability for Bunker Oil Pollution Damage, 2001

Table A-2 – Terminal contingency planning documents

Regulatory Body	Regulation
Preparedness and response	
Province of British Columbia	<ul style="list-style-type: none"> • Emergency Management Regulation under the OGAA • Liquefied Natural Gas Facility Regulation [41] • Spill Reporting Regulations [42] under BC’s Environmental Management Act [43]
Environment and Climate Change Canada	<ul style="list-style-type: none"> • Environmental Emergency Regulations, 2019 [44] (enabling statute Canadian Environmental Protection Act, 1999 [45])
Canadian Standards Association (CSA)	<ul style="list-style-type: none"> • Z246.2-18 - Emergency preparedness and response for petroleum and natural gas industry systems [46] • CSA Z662:23 - Oil and gas pipeline systems [47] • CSA Z276 LNG— Production, Storage, and Handling [48]
Transport Canada	<ul style="list-style-type: none"> • Canada Shipping Act, 2001 [18] • Response Organizations Regulations [20] • Response Organizations Standards (TP 12401) [22] • Environmental Response Regulations

1 **ATTACHMENT E.7 TERMINAL OPERATIONS MANUAL**



Ksi Lisims LNG
Navigation Safety Assessment

Terminal Operations Manual

11 October 2023



Disclaimer

This report is not intended to stand alone without reference to the instructions given to Westmar by Ksi Lisims LNG, communications between Westmar and Ksi Lisims LNG, and any other reports, proposals or documents prepared by Westmar for Ksi Lisims LNG under the governing contract between Westmar and Ksi Lisims LNG. To understand the suggestions, recommendations and opinions expressed herein, reference must be made to all relevant documents and communications.

This report has been prepared only for the purposes that are set out in the governing contract between Westmar and Ksi Lisims LNG. The findings, recommendations, suggestions and or opinions expressed in this report are only applicable to the purposes for which the report is expressly provided, and then only to the extent that there has been no material alteration to or variation from the information provided or available to Westmar.

The information and opinions expressed in this report are for the sole use and benefit of Ksi Lisims LNG. No other party may use or rely upon the report or any portion thereof without Westmar's prior written consent, and such use shall be on terms and conditions as Westmar expressly approves. Ownership in and copyright for the contents of the report belong to Westmar. Any use which a third party makes of the report is the sole risk and responsibility of such third party. Westmar accepts no responsibility whatsoever for loss or damages suffered by any third party in relation to use of this report.

Company Details

Westmar Advisors Inc.
700 - 1901 Rosser Avenue
Burnaby, BC, V5C 6R6

T 604 770 4787

info@westmaradvisors.com

Table of Contents

Abbreviations	iv
Preface	ix
1 Introduction	1
1.1 Objective	1
1.2 Scope	1
1.3 Communication	1
1.4 Waste Management	2
1.5 Operating Limits	2
1.6 Terminal Checklists	2
2 Terminal Operations Manual	3
2.1 Preliminary Table of Contents	3
References	7

Abbreviations

Abbreviation	Description
°C	degrees Celsius
ABS	American Bureau of Shipping
ADCP	acoustic doppler current profiler
AIS	automatic identification system
AIS ATON	automatic identification system aid to navigation
AK	Alaska
ANSI	American National Standards Institute
ARI	average recurrence interval
ATON	aids to navigation
BC	British Columbia
BCCP	British Columbia Coast Pilots Ltd.
BCER	BC Energy Regulator
BNWAS	bridge navigational watch alarm system
BOG	boil off gas
BV	Bureau Veritas
CCG	Canadian Coast Guard
CHS	Canadian Hydrographic Services
CMB	continuous marine broadcast
CPAs	Compulsory Pilotage Areas
DAS	docking assist system
deg	degree
DFO	Fisheries and Oceans Canada
DNV	Det Norske Veritas
dwt	deadweight tonnage
EA	environmental assessment
ECCC	Environment and Climate Change Canada
ECDIS	electronic chart display and information system
EDG	emergency diesel generators
EEBD	Emergency Escape Breathing Device
EMSA	enhanced maritime situation awareness
ENC	electronic navigational chart
EOC	Emergency Operations Centre
EPIRB	emergency position-indicating radio beacon
ERS	emergency release system

Abbreviation	Description
ESD	emergency shut down
ETA	estimated time of arrival
EU	environmental unit
FEED	front-end engineering design
FFA	fire fighting appliances
FLNG	floating liquefaction, storage, and off-loading barge
FMBS	full mission bridge simulation
FMO	Federal Monitoring Officer
FSA	Formal Safety Assessment
FSRU	floating storage and regassification units
GMDSS	Global Maritime Distress, and Safety System
GNSS	Global Navigation Satellite System
GTT	Gaztransport and Technigaz
HFO	heavy fuel oil
HNS	hazardous and noxious substances
Hs	significant wave height
IACS	International Association of Classification Societies
IALA	International Association of Marine Aids to Navigation and Lighthouse Authorities
ICS	Incident Command System
IGC Code	<i>International Code for the Construction and Equipment of Ships Carrying Liquefied Gases in Bulk</i>
ILO	International Labour Organization
IMO	International Maritime Organization
ISGOTT	<i>International Safety Guide for Oil Tankers and Terminals</i>
ISM	International Safety Management
ISPS	<i>International Ship and Port Facility Security Code</i>
kHz	kilohertz
km	kilometre
kn	knot
LBP	length between perpendiculars
LFL	lower flammability limit
LLWLT	lower, low water, large tide
LNG	liquefied natural gas
LOA	length overall
LOS	level of service
LPG	liquefied petroleum gas
LR	Lloyd's Register

Abbreviation	Description
LSA	life-saving appliances
LSIR	location specific individual risk
LTA	line throwing appliance
m	metre
m	metres per second
m ²	square metres
m ³	cubic metres
m ³	cubic metres
m ³ / hour	cubic metres per hour
MARPOL	<i>International Convention for the Prevention of Pollution of Ships</i>
MCTS	Marine Communications and Traffic Services
MDO	marine diesel oil
MGO	marine gas oil
MOF	material off-loading facility
MOU	Memorandum of Understanding
MSI	Marine Safety Inspectors
MSOC	Marine Security Operations Centre
MTBE	methyl tertiary butyl ether
mtpa	million tonnes per annum
NASP	National Surveillance Aerial Program
NAVTEX	Narrow Band Direct Printing Telegraphy
NAVWARN	navigational warnings
NGL	natural gas liquid
NK	Nippon Kaiji Kyokai
NLG	Nisga'a Lisims Government
NLS	Noxious Liquid Substances
NOA	notice of arrival
North Coast	north coast of British Columbia
NOTMAR	Notices to Mariners
NRA	BCCP / PPA Navigational Risk Assessment
NSA	navigation safety assessment
NW	northwest
OCIMF	Oil Companies International Marine Forum
ODAS	ocean data acquisition system
OGAA	<i>Oil and Gas Activities Act</i>
OPP	Oceans Protection Plan

Abbreviation	Description
OPRC	<i>International Convention on Oil Pollution Preparedness, Response and Co-operation</i>
OSC	On-Scene Commander
P&I	protection and indemnity (insurance)
P&I	protection and indemnity
PAH	polycyclic aromatic hydrocarbons
PAIR	Pre-Arrival Information Reports
PIANC	World Association for Waterborne Transport Infrastructure
PMS	planned maintenance system
PORCP	National Places of Refuge Contingency Plan
PPA	Pacific Pilotage Authority
PPO	Pollution Prevention Officer
PPU	portable pilot units
PRPA	Prince Rupert Port Authority
PRPRCP	<i>Pacific Region Places of Refuge Contingency Plan</i>
PSC	Port State Control
QCDC	quick connect disconnect couplers
QRA	quantitative risk assessment
QRH	quick release hooks
QSCS	Quality System Certification Scheme
racon	radar beacon
RNC	raster navigational chart
RO	recognized organization (with respect to flag state affairs)
RO	response organization (with respect to spill response)
RT	radiotelephony
s	seconds
SAR	search and rescue
SIGTTO	Society of International Gas Tanker and Terminal Operators
SIRE	Ship Inspection Report Programme
SMPEP	Shipboard Marine Pollution Emergency Plan
SOLAS	<i>International Convention for the Safety of Life at Sea (SOLAS), 1974</i>
SOPEP	Shipboard Oil Pollution Emergency Plan
SOPF	Ship-source Oil Pollution Fund
SSL	ship-shore link
STCW	<i>International Convention on Training, Certification, and Watchkeeping for Seafarers</i>
SW	southwest
SWL	safe working load

Abbreviation	Description
t	metric tonne (equal to 1,000 kilograms)
TCMSS	Transport Canada Marine Safety and Security
TERMPOL	Technical Review Process of Marine Terminal Systems and Transshipment Sites
TOM	Terminal Operations Manual
Tp	peak wave period
TSB	Transportation Safety Board of Canada
UKC	underkeel clearance
US	United States
V-ATON	virtual aid to navigation
VDR	voyage data recorder
VHF	very high frequency
VLSFO	very low sulphur fuel oil
VTS	Vessel Traffic Services
WCMRC	Western Canada Marine Response Corporation

Preface

A Navigation Safety Assessment (NSA) is part of the Application. The NSA is an opportunity to review the Ksi Lisims LNG Project and determine whether additional resources (e.g., pilots), controls or infrastructure (e.g., navigational aids) are required and when they need to be in place. The NSA studies make-up Appendix E and findings inform Section 9 Malfunctions and Accidents and other sections (e.g., Section 7.11 Marine Use). Section 9.1.2 Planning provides a list and high-level description of the NSA studies. Additional navigation simulations will be completed before the start of operations and will be the subject of approval conditions.

1 Introduction

This report describes the Ksi Lisims LNG *Terminal Operations Manual* (TOM) for the Ksi Lisims LNG - Natural Gas Liquefaction and Marine Terminal Project (the Project).

1.1 Objective

The objective of the TOM is to provide liquefied natural gas (LNG) carriers and natural gas liquid (NGL) product vessels with important marine route and marine terminal information. A draft table of contents for the TOM is in Section 2.

The TOM does not address operations on the floating liquefaction, storage, and off-loading barges (FLNGs) or at the upland terminal facilities, which will be covered under separate documents.

1.2 Scope

These topics are addressed in the TOM:

- Safety, security, and environmental policies
- Purpose and objectives
- Terminal information
- Terminal rules and regulations
- Emergency management
- Terminal security
- Terminal requirements
- Pre-arrival requirements
- Requirements for berthing, unberthing and alongside
- Cargo loading procedures
- Marine terminal departure procedures
- Appendices, including:
 - Navigation chart and important locations (not for navigation)
 - Terminal compatibility data
 - Communications matrix

1.3 Communication

The TOM will include a schedule of communications the master of the LNG carrier or NGL product vessel must initiate with:

- The marine terminal operator
- The LNG carrier or NGL product vessel agent
- The Pacific Pilotage Authority
- The Canadian Coast Guard
- Transport Canada Marine Safety and Security

Timing of scheduled messages should account for common delays in message handling and distribution, other than during direct vessel-to-terminal communications.

The TOM will also describe communication interfaces between the LNG carriers or NGL product vessels and the marine terminal.

1.4 Waste Management

The TOM will address the management of hazardous and non-hazardous waste under the *International Waste Directive* [1].

1.5 Operating Limits

The TOM will state the upper limit of all metocean factors that would require stopping cargo transfer operations or require LNG carriers or NGL product vessels to depart the marine terminal. Preliminary operating limits are provided in the *Terminal Plans and Cargo Transfer Report* [2].

The Project will work with the Pacific Pilotage Authority (PPA) and the BC Coast Pilots Ltd. (BCCP) to establish operating limits for berthing and unberthing at the marine terminal. As described in the other NSA reports, the BCCP / PPA will also complete a joint Navigational Risk Assessment (NRA).

1.6 Terminal Checklists

The TOM will be based on industry best practices and incorporate the *International Safety Guide for Oil Tankers and Terminals* (ISGOTT) and Society of International Gas Tanker and Terminal Operators (SIGTTO)'s ship/shore guidelines and checklists.

2 Terminal Operations Manual

The TOM will be provided to relevant agencies at least six months before operations begin and will be the subject of approval conditions.

2.1 Preliminary Table of Contents

The following is the preliminary table of contents for the TOM.

Cover

1. Policies

- 1.1. Safety
- 1.2. Security
- 1.3. Environment

2. Introduction

- 2.1. Definitions
- 2.2. Purpose and objectives
- 2.3. Required compliance

3. Terminal Information

- 3.1. General
 - 3.1.1. Terminal location
 - 3.1.2. Weather
 - 3.1.3. Terminal description
 - 3.1.4. Cargo types
- 3.2. Navigation
 - 3.2.1. Marine route
 - 3.2.2. Charts
 - 3.2.3. Nautical publications
 - 3.2.4. Traffic services
 - 3.2.5. Pilot boarding
 - 3.2.6. Pilotage
 - 3.2.7. Marine mammals
- 3.3. Tug requirements and joining location(s)
- 3.4. Communications
- 3.5. Services
 - 3.5.1. Fuel
 - 3.5.2. Fresh water
 - 3.5.3. Stores
 - 3.5.4. International waste

4. Terminal Rules and Regulations

- 4.1. General
- 4.2. Rules and regulations
- 4.3. Terminal policies
 - 4.3.1. Safety
 - 4.3.2. CCTV
 - 4.3.3. Maintenance and repairs
 - 4.3.4. Visitors

- 4.3.5. Shore leave and crew exchanges
- 4.3.6. Medical access
- 4.3.7. Spares and stores
- 4.3.8. Fuelling
- 4.3.9. Ballast water
- 4.3.10. Waste management
 - 4.3.10.1. Garbage
 - 4.3.10.2. Oily waste
 - 4.3.10.3. Black and grey water

5. Emergency Management

- 5.1. General
- 5.2. Emergency contacts
- 5.3. Emergency response equipment
- 5.4. Emergency departure
 - 5.4.1. Tug availability
 - 5.4.2. Engine readiness
 - 5.4.3. Mooring lines
- 5.5. Emergency on a vessel
 - 5.5.1. Actions by vessel
 - 5.5.2. Actions by terminal
- 5.6. Emergency on the FLNG / terminal
 - 5.6.1. Actions by vessel
 - 5.6.2. Actions by terminal
- 5.7. Other emergencies
 - 5.7.1. Actions by vessel and terminal

6. Terminal Security

- 6.1. General
- 6.2. Security and safety zone
- 6.3. Reporting to terminal facilities
- 6.4. Third party / visitor access
- 6.5. Unmanned aerial vehicles and photos

7. Terminal Requirements

- 7.1. Compatibility
 - 7.1.1. Vessel size
 - 7.1.2. Mooring and fendering
 - 7.1.3. Gangway
 - 7.1.4. Transfer arrangement
 - 7.1.5. Transfer operations
 - 7.1.6. ESD
 - 7.1.7. Communications
- 7.2. Ship Inspection Report Programme (SIRE) inspection
- 7.3. Port state control status
- 7.4. Vessel condition
- 7.5. Tank condition

8. Pre-Arrival Requirements

- 8.1. Terminal notifications
 - 8.1.1. Schedule

- 8.1.2. Security levels
- 8.1.3. Tank condition
- 8.1.4. Vessel declaration
- 8.2. Pilot notifications
- 8.3. Notice of arrival

9. Requirements for Berthing, Unberthing and Alongside

- 9.1. Harbour tugs
- 9.2. Mooring
 - 9.2.1. Approach speed indicator board
 - 9.2.2. Line handling
 - 9.2.3. Management of moorings
 - 9.2.4. Towing-off pendants
- 9.3. Gangway
- 9.4. Terminal operational restrictions
 - 9.4.1. Operating wind speed guidelines
 - 9.4.2. Departing terminal due to high winds

10. Cargo Loading Procedures

- 10.1. Pre and post transfer meeting
- 10.2. Custody transfer surveys
- 10.3. Safety walk around
- 10.4. Connection and disconnection
- 10.5. ESD and communications testing
- 10.6. Transfer sequence and rates
- 10.7. Record keeping
- 10.8. Ballasting
- 10.9. Management of moorings
- 10.10. Operational and berth limits
 - 10.10.1. Monitoring
 - 10.10.2. Forecasts
 - 10.10.3. Pilot dispatch notifications
- 10.11. Emergency signals and actions
- 10.12. Ship / shore safety checklist
- 10.13. Terminal representative
- 10.14. Cargo transfer
 - 10.14.1. Cooldown
 - 10.14.2. Ramp up
 - 10.14.3. Loading
 - 10.14.4. Ramp down
 - 10.14.5. Cargo arm draining, purging, and disconnection
- 10.15. Monitoring while alongside
 - 10.15.1. Security
 - 10.15.2. Local weather
 - 10.15.3. Long range weather

11. Marine Terminal Departure Procedures

- 11.1. Notifications
- 11.2. Pilot boarding and disembarkation
- 11.3. Berthing tugs and escort tugs
- 11.4. Notifications after pilot away

Appendices

- A) Navigation chart and important locations (not for navigation)
- B) Terminal compatibility data
- C) Communications matrix

References

- [1] Canadian Food Inspection Agency, "International Waste Directive," Nov. 11, 2011.
<https://inspection.canada.ca/animal-health/terrestrial-animals/imports/import-policies/general/2002-17/eng/1321050654899/1323826743862> (accessed Nov. 15, 2022).
- [2] Westmar Advisors Inc., "Terminal Plans and Cargo Transfer," 1220197-P01-25-RPT-0001, 2023.